



Original

# Installation And Service Manual

## FLUSH-MOUNT SCISSORS LIFT

### Model: XL-10F

#### **Cargo Claims**

If there is any missing or damaged product during transportation, the buyer must not sign on the shipping paperwork or refuse the shipment. NOTATE ALL DAMAGE OR REFUSE DAMAGED SHIPMENT!



#### DANGER

Read the entire contents of this manual before using this product. Failure to follow instructions and safety precautions could result in serious injury or even death. Make sure all other operators also read this manual. Keep this manual near the machine so that it can be seen by all users. By proceeding with installation and operation, you agree that you are fully understand the contents of this manual and take full responsibility for the use of the product.

# CONTENTS

PROFILE .....	1
IMPORTANT SAFETY INSTRUCTIONS .....	3
I. PRODUCT FEATURES AND SPECIFICATIONS .....	5
II. INSTALLATION REQUIREMENT .....	7
III. INSTALLATION STEPS .....	9
IV. TEST RUN .....	16
V. EXPLODED VIEW .....	22
VI. OPERATION INSTRUCTIONS .....	29
VII. MAINTENANCE SCHEDULE .....	30
VIII. TROUBLE SHOOTING .....	32
IX. CAR LIFT SAFETY TIPS .....	33
X. LIFT DISPOSAL .....	33

## Explanation of the safety warning symbols used in this manual

-  DANGER Risk of death or injury
-  WARNING Dangerous or unsafe practices that may result in death or injury
-  CAUTION Dangerous or unsafe practices that may result in personal injury, product damage or property damage
- ATTENTION Conditions that may result in damage to products or property

## **PROFILE**

The scissor lift is a commonly used vehicle repair and maintenance tool that uses a hydraulic that can lift the car up to a certain height so that the vehicle can be placed in a suitable position for inspection and repair which have the characteristics of safe and reliable, simple structure and quick installation.

This instruction manual is specially prepared for you. Your new lift is the product of over a decade of continuous research, testing and development and is the most technologically advanced lift on the market today.

**Please make sure to read through this manual before operating the lift.**

Record the information on the nameplate label here:

Model No.: \_\_\_\_\_

Serial No.: \_\_\_\_\_

Manufacturer date: \_\_\_\_\_

## **WARRANTY**

The warranty period for the steel structure part of new car lift is 5 years, hydraulic components, bronze bushings, sliders and plastic parts are under warranty for 3 years, and electrical components and sync cable, lock release cable warranty for 2 year.

Rubber pads are without warranty. During the warranty period, the manufacturer will repair or replace the defective parts free of charge including shipping costs.

This warranty does not cover damage caused by normal wear and tear, improper use, damage in transit, or damage caused by lack of maintenance.

This warranty is unique and supersedes what is expressed and implied in all other warranties. The manufacturer shall not be liable for any particular, indirect or accidental damage resulting in breach of or delay in the execution of the warranty. The manufacturer reserves the right to design and improve the product and has no obligation to make notice of the changes in advance.

The product warranty based on the above clause is based on the model number and serial number of the equipment. This information must be provided in conjunction with all warranty information at the time of service and warranty.

# SAFETY WARNING LABEL



Fig.1

## **IMPORTANT SAFETY INSTRUCTIONS**

In order to properly maintain your product and ensure operator safety, it is the responsibility of the product owner to read and follow these instructions!

1. Ensure product installation complies with all applicable local regulations and rules, such as Occupational Safety and Health Administration regulations and electrical codes.
2. Ensure that all operators are properly trained, know how to operate the unit safely, and are properly supervised.
3. Do not operate the lift until you are sure all parts are in place and operating correctly.
4. Keep your hands and feet away from the machine. Keep hands and feet away from any moving parts. Keep your feet away from the lift as it descends to avoid pressing on pointed objects.
5. Keep the work area clean. A cluttered workspace can lead to injuries.
6. The machine is only approved for indoor installation and use. Outdoor installation is prohibited.
7. Only trained operators are allowed to handle the lift machine. All untrained persons must stay away from the workplace. Never allow untrained persons to handle or operate the machine.
8. Use the lift properly. Use the lift in the correct way.
9. Warning! Keep persons and objects from the lift when lifting the a vehicle.
10. If the vehicle is at risk of falling, make sure no one is around the lift.
11. Before preparing to approach or service the vehicle, ensure that the safety device is in effect.
12. Dress appropriately when operating machines, and consider wearing non-slip steel-toe shoes for added safety..
13. Beware of electric shock. In order to protect the operator from electric shock, the lift in use must be grounded. Do not connect the green wire to the terminal. This is the ground wire.
14. Danger! The power supply used in this type of lift has high voltage. Please disconnect the power supply before any circuit repair. Unplug in case the power supply is accidentally switched on during maintenance.
15. Warning! There is a risk of explosion. There are parts in the equipment that produce arc light and spark. Do not operate near flammable gas. This machine should not be placed in the lounge or basement.
16. Maintain with care. Keep the machine clean for better and safer operation. Perform

proper lubrication and maintenance procedures according to the manual. Keep handles or buttons clean, dry, and free of oil.

17. Stay alert. Use common sense to observe what you are doing and stay alert.
18. Check for damaged parts. Check for adjustments to moving parts, damage to parts, or anything that may affect their operation. Do not use the machine if the parts are damaged.
19. Do not remove relevant safety parts from the machine. Do not use a lift if it is damaged or missing.
20. Only operate the lift at temperature between 5°C to 40°C(41°F to 104°F).

 **DANGER** Be very careful when installing, operating, maintaining or repairing this equipment. Failure to comply may result in property damage, product damage, injury or (in very rare cases) death. Ensure that only authorized personnel operate the equipment. All repairs must be carried out by an authorized technician. Do not modify the machine, this voids the warranty and increases the probability of personal injury or property damage. Ensure to read and follow this instructions on the label.

## I. PRODUCT FEATURES AND SPECIFICATIONS (See Fig.2)

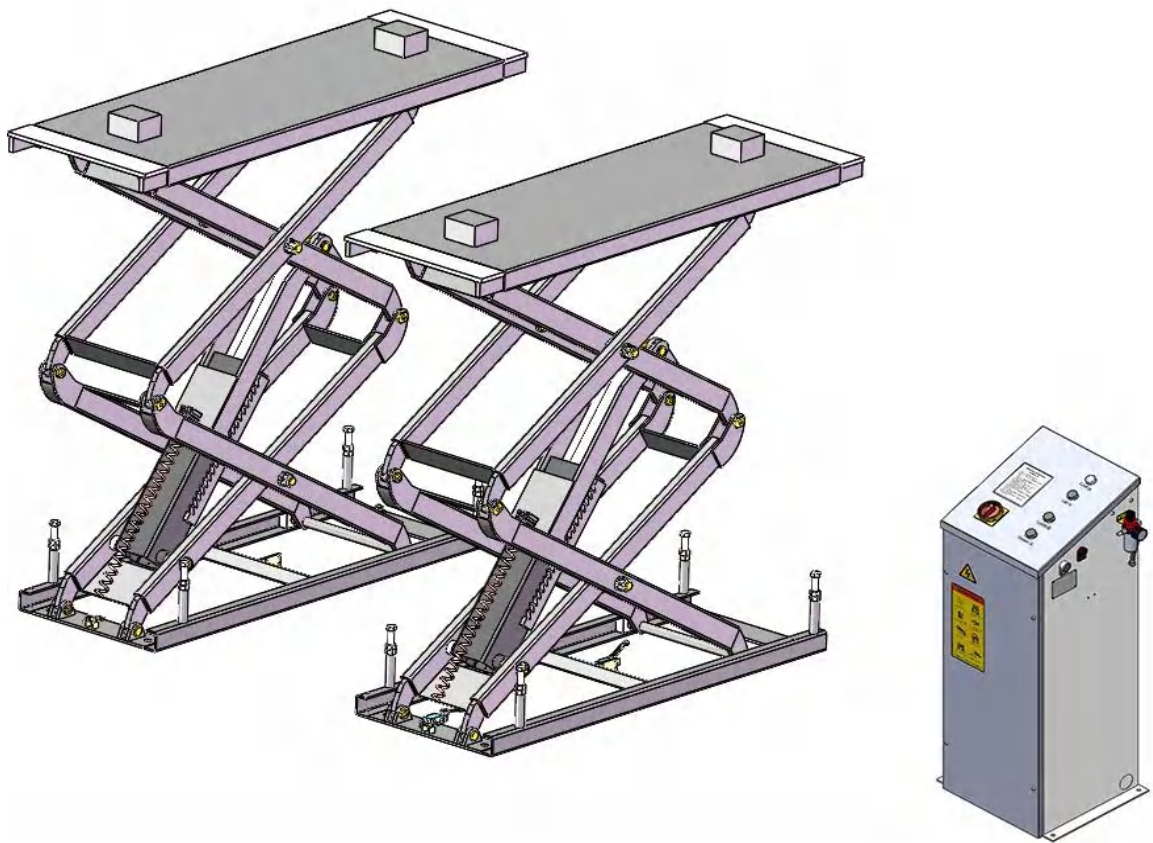

**Fig.2**

### **FLUSH-MOUNT SCISSORS MODEL XL-10F**

- Electronic control operating system, friendly to use.
- Dual tooth self-locking mechanism, pneumatic release, safe and reliable.
- Dual cylinders automatic synchronization system.
- Extendable platforms are suitable for various wheelbase models.
- Photocell switch is equipped as standard.

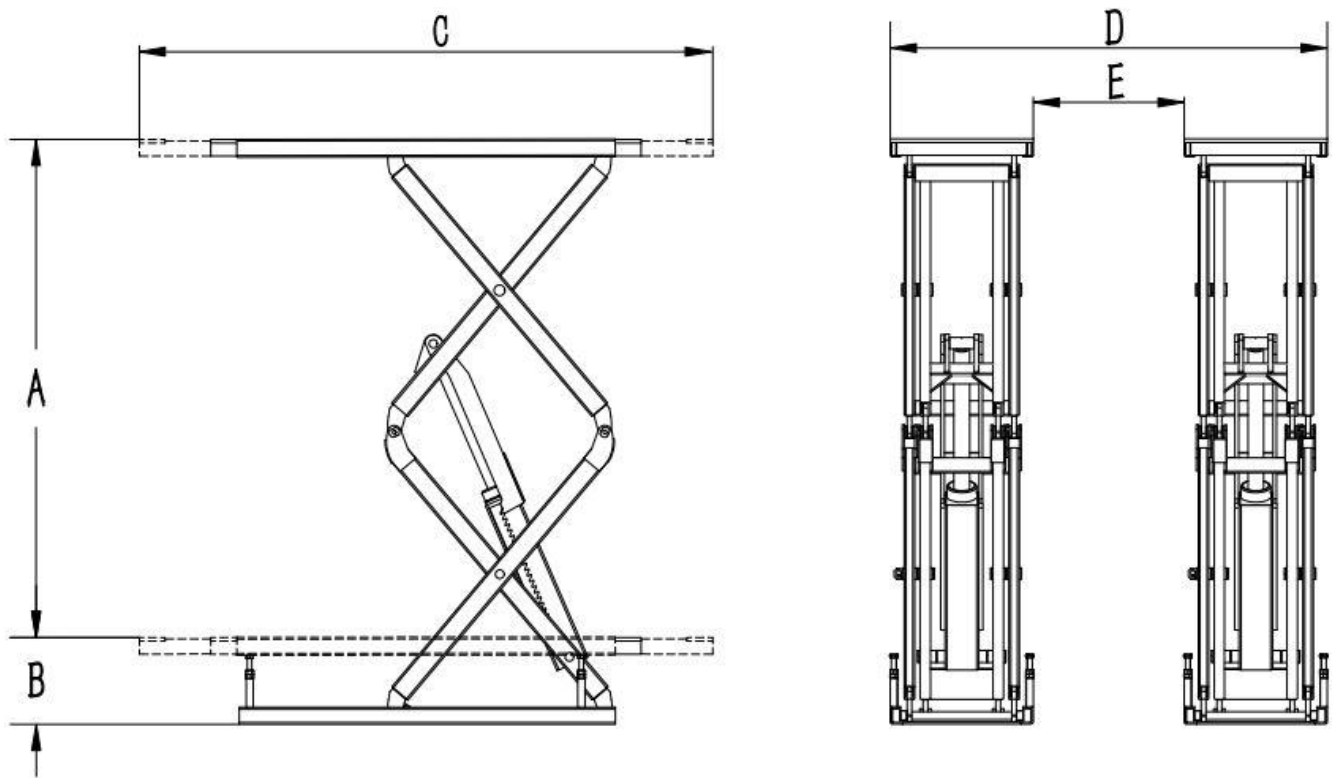

**Fig. 3**

**MODEL XL-10F SPECIFICATIONS**

Model	Lifting Capacity	Lifting Time	A		B	C	D	E	Motor
			Max Lifting Height	Max Lock Height	Min. Height	Overall Length	Overall Width	Width Between runways	
XL-10F	10000lbs	49s	75"	72 5/8"	13 3/4"	65 1/8"~ 80 5/16"	75 7/16"	31 1/2"	2.0HP

**⚠ CAUTION** When driving the vehicle, stay in the middle between the platforms. If you hit any part of the lift, you could damage the car or lift.

## II. INSTALLATION REQUIREMENT

### A. TOOLS REQUIRED

- ✓ Rotary Hammer Drill  
( $\Phi 19$ 、 $\Phi 10$ 、 $\Phi 4$ )



- ✓ Hammer



- ✓ Level Bar



- ✓ Adjustable Spanner (12")



- ✓ Wrench set ( 15#, 17#)



- ✓ Grease gun



- ✓ Carpenter's Chalk



- ✓ Screw Sets



- ✓ Tape Measure (7.5m)



- ✓ Pliers



- ✓ Lock Wrench



- ✓ Ratchet Spanner with Socket

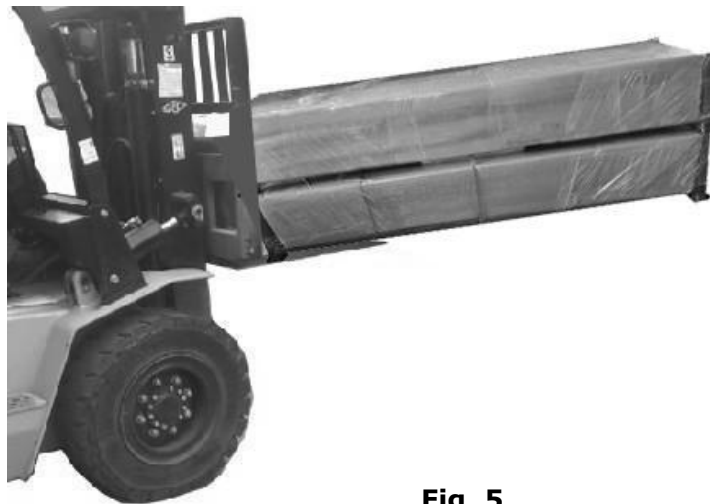

Fig. 4

## **B. Equipment storage and installation requirements.**

- 1 . Store the equipment in a dry, non-moldy, non-flammable environment.
- 2 . The lift is only approved for indoor installation and use, and outdoor installation is prohibited.
- 3 . When installing the device, take safety precautions according to the instructions to avoid device damage.
- 4 . During installation, all parts should be fastened to ensure the stability and smooth operation of the machine.
- 5 . After installation, the whole machine should be checked to make sure that every component is working properly.

## **C. The equipment should be unload and transfer by forklift.**



**Fig. 5**

## **D. SPECIFICATIONS OF CONCRETE**

**Specifications of concrete must be adhered to the specifications as following.**

**Failure to do so may result in lift and/or vehicle falling.**

1. Position of the lift: Design with a professional architect if possible. Check the required layout dimensions to ensure sufficient space.
2. Overhead obstruction: There should be no obstacles above the position of the lift, such as heat sources, building support columns and wires.
3. Concrete: floors must be level and contain no cracks or holes. Concrete must be of test strength 3,000psi minimum, thickness 4" minimum. Failure to comply with this requirement may cause injury.

## E. POWER SUPPLY

1. You are required to use a licensed and qualified electrician for the installation process.
2. **The power supply should be 220V 60Hz**, with a cord larger than 12AWG, and must be properly grounded.

**⚠ DANGER** All electrical wiring must be performed by a licensed and certified electrician. Attempting to connect the circuit without proper certification may result in damage to the lift or electrocution, resulting in serious injury or death.

## III. INSTALLATION STEPS

### A. Location of installation

1. Installation space: Ensure there is enough space for the lift. Accurately measure the front, back, side and top mounting dimensions and refer to the below figure data (**See Fig. 6**).
2. Overhead obstacle: Check for overhead obstacles, such as building supports, heaters, lights, wires, and low ceilings, etc..
3. Installation: The lift is only approved for indoor installation and use, and outdoor installation is prohibited.
4. Floor: Install lift only on flat concrete floor. Do not install on asphalt or any other surface.
5. Install space:

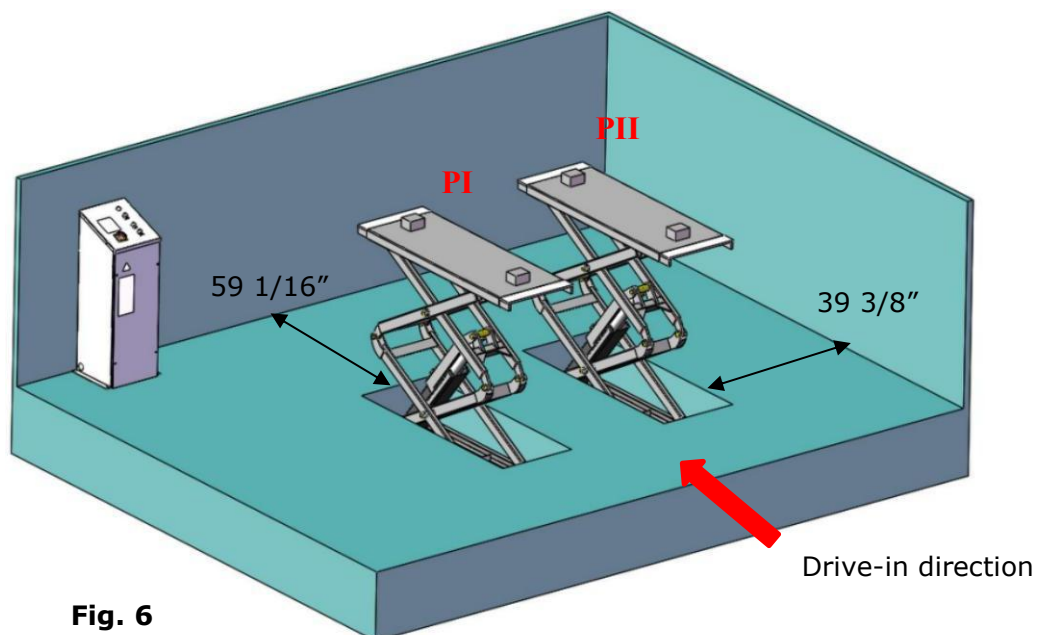

**Fig. 6**

6. Review the layout as shown below and select a location that is best suited for your application. Be sure to use the dimensions that are applicable to your lift model.

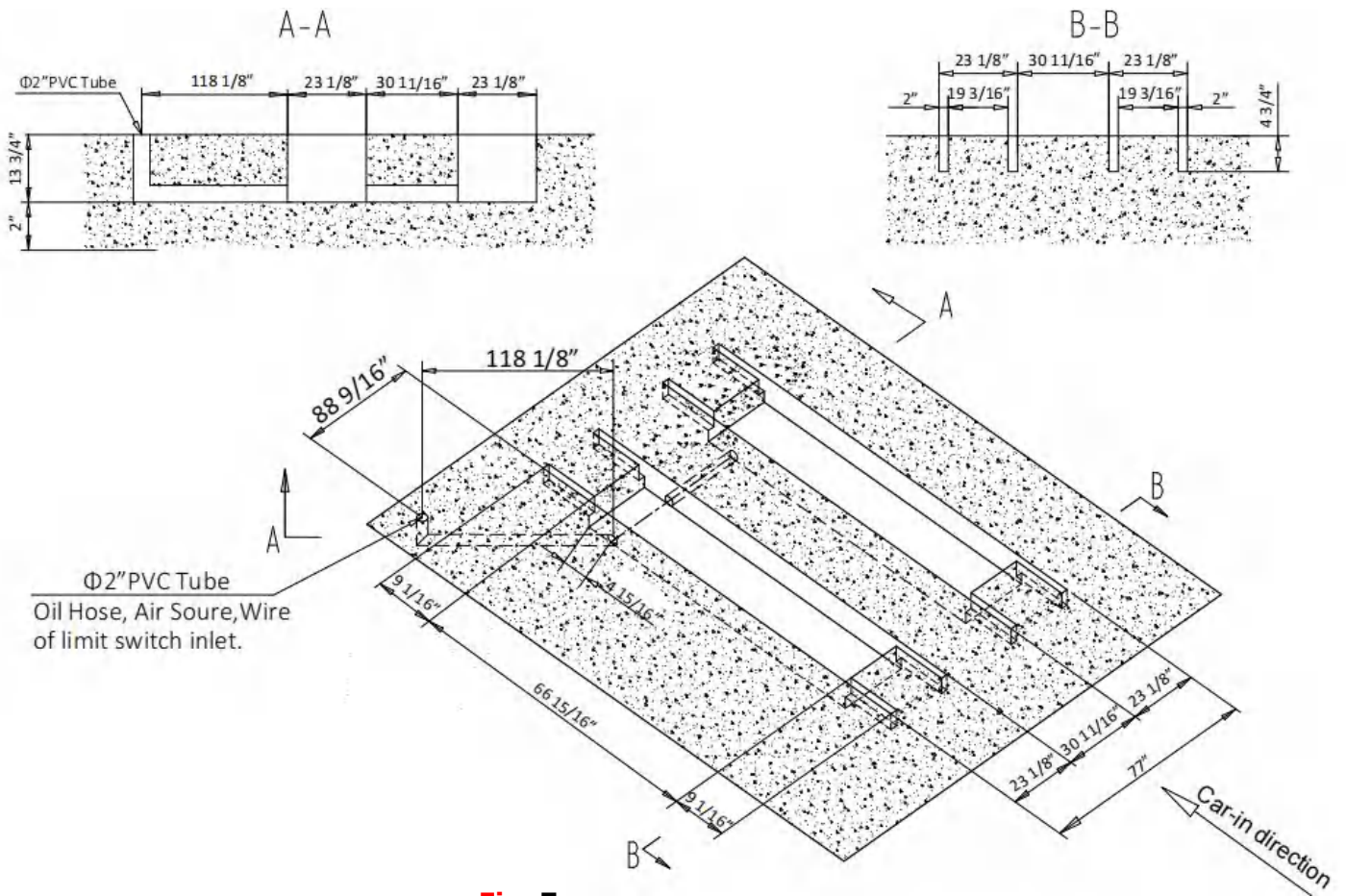

**Fig. 7**

**Note:** a. Concrete must be thickness 4" minimum and must be of test strength 3,000psi minimum.

b. All the tubes must be  $\Phi 2$ " PVC tube.

**B. Check the parts before assembly, make sure all the parts are well received.**

1. Whole set of one unit (Packaged lift and hydraulic power unit). **(See Fig.8)**



**Fig. 8**

2. Take off the packing shelf, open the outer packing and check the parts according to the shipment parts list. **(See Fig. 9)**

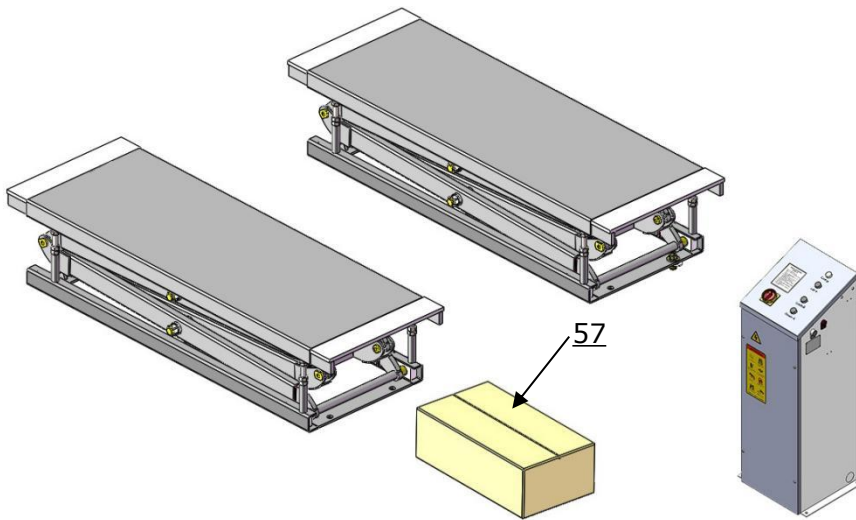

**Fig. 9**

3. Open the parts box, check the parts according to the part list. **(See Fig. 10)**



**Fig. 10**

4. Check the parts of the parts bag according to the parts bag list. **(See Fig. 11)**



**Fig. 11**

### C. Layout the machine and install hydraulic system and air line system.

1. Layout the equipment with forklift or other equipment to the location according to **Step B**. Lift the equipment up to about 1-meter-high and lock on the safety mechanism, take out oil hoses under the platform **PI**. (See Fig. 12)

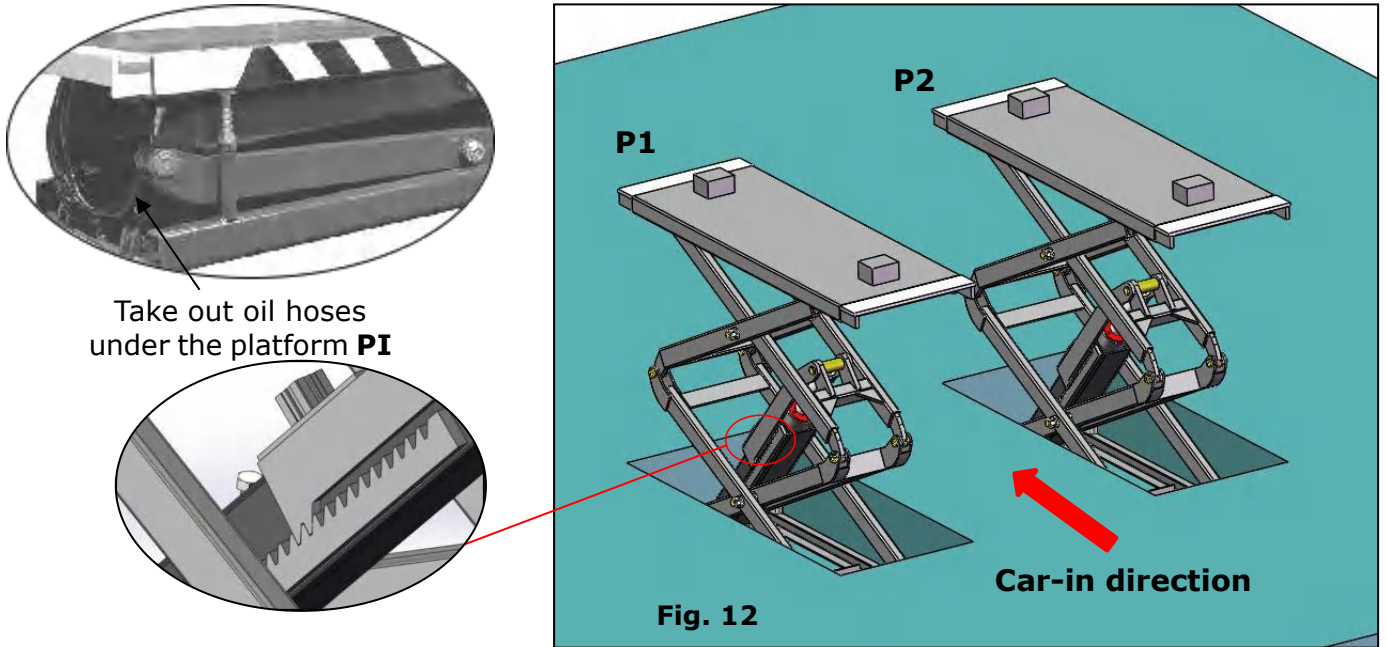

2. Locate the control cabinet to the preserved place, install relevant air lines and wires through the embedded PVC pipe.

3. Connecting the air line (See Fig. 13)

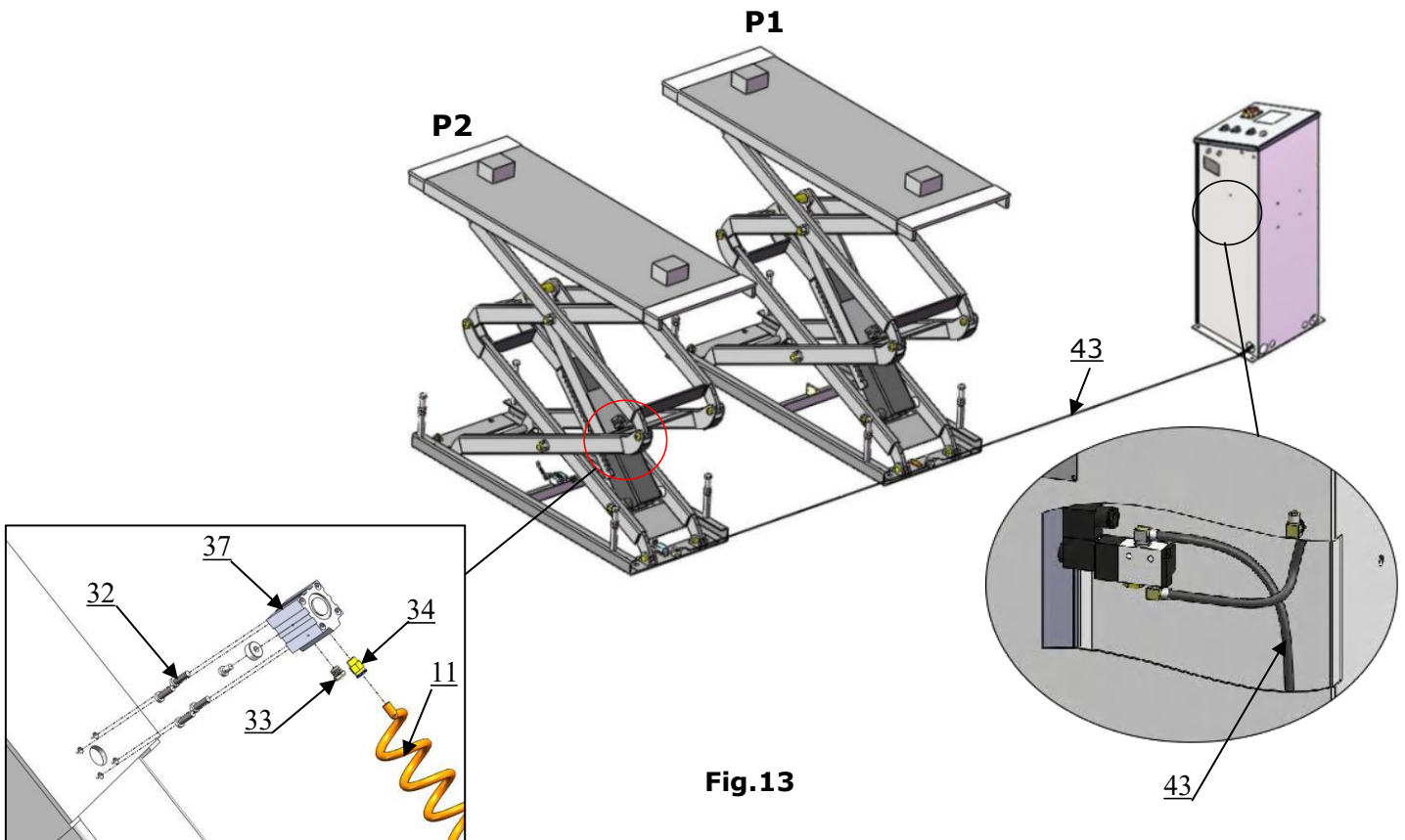

4. Install the oil-water separator. (See Fig. 14)

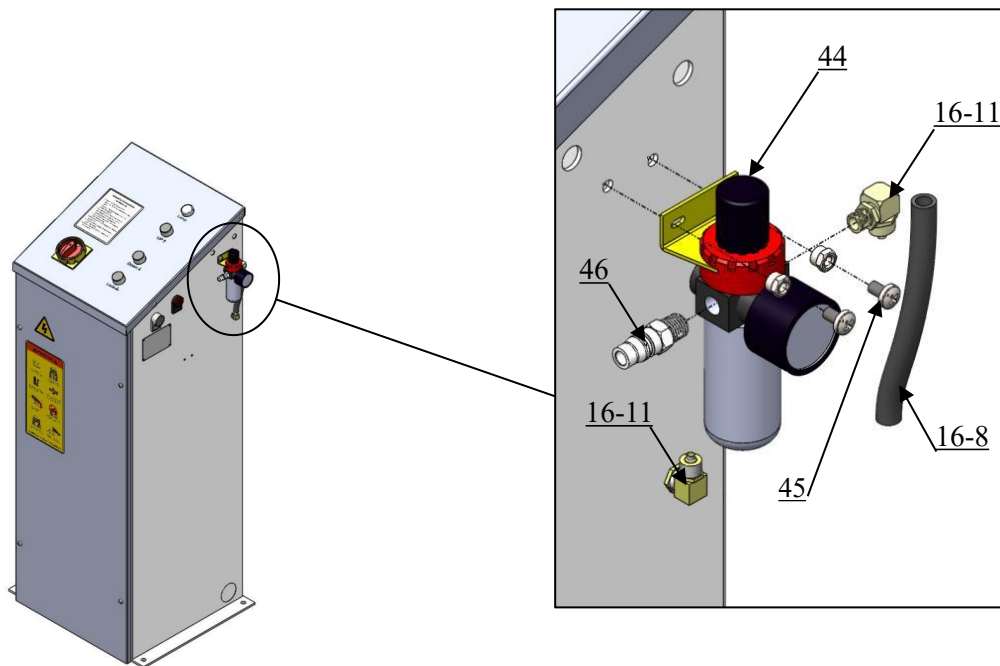

Fig. 14

5. Connect air inlet, adjust the air pressure of oil-water separator to 0.8MPa. (See Fig.15)

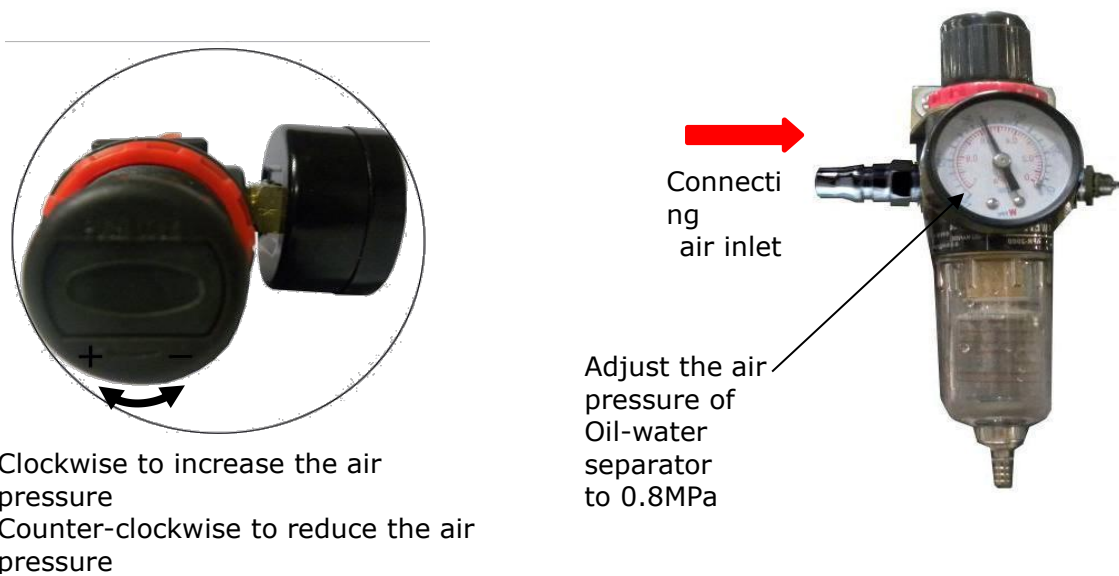

Fig. 15

6. Connect oil hoses assy. (See Fig.16)

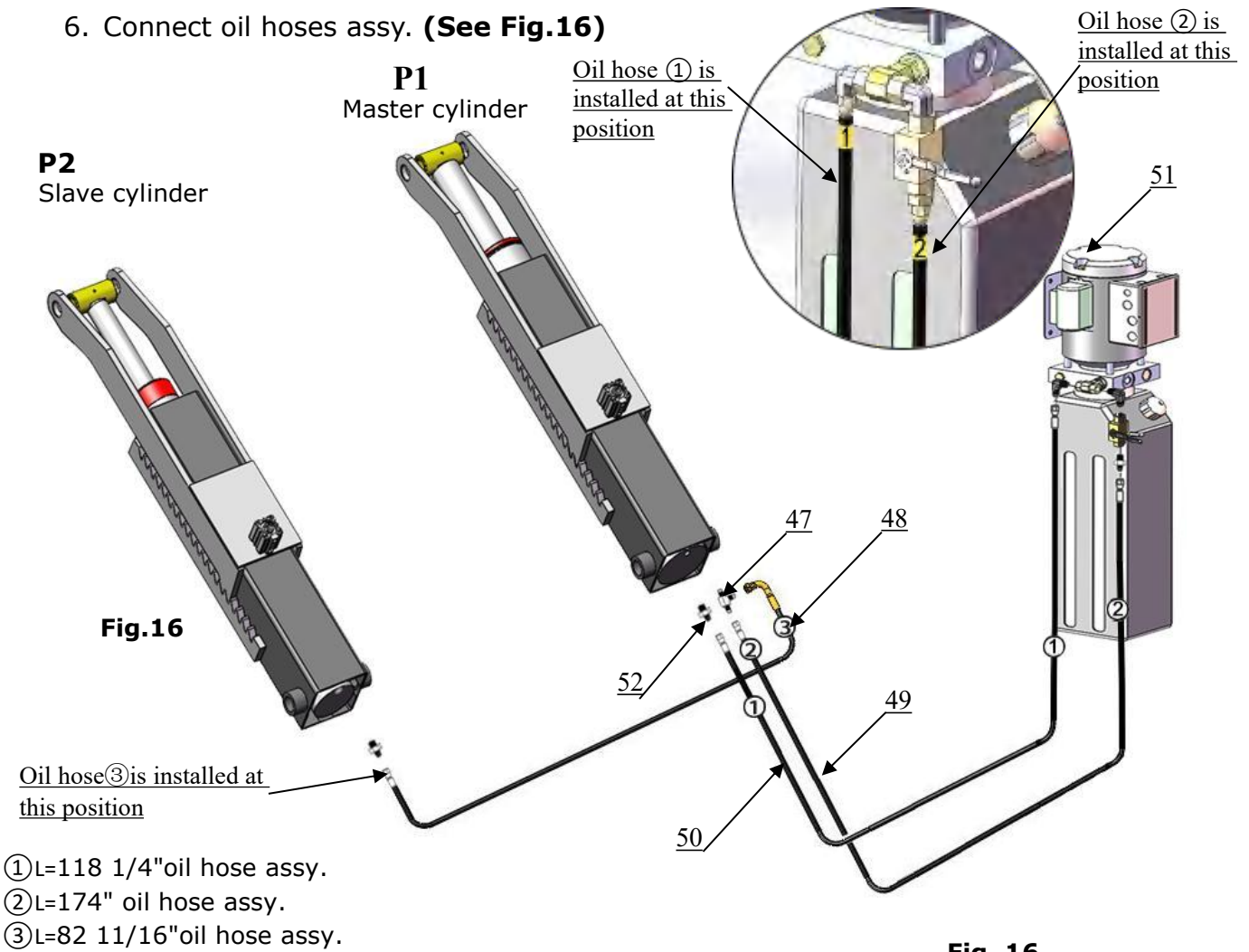

Fig. 16

**D. Install electric system**

**1. Wire connection for single phase power unit**

1.1 Connect the power wire and limit switch wire according to the Wiring diagram. (See Fig. 17)

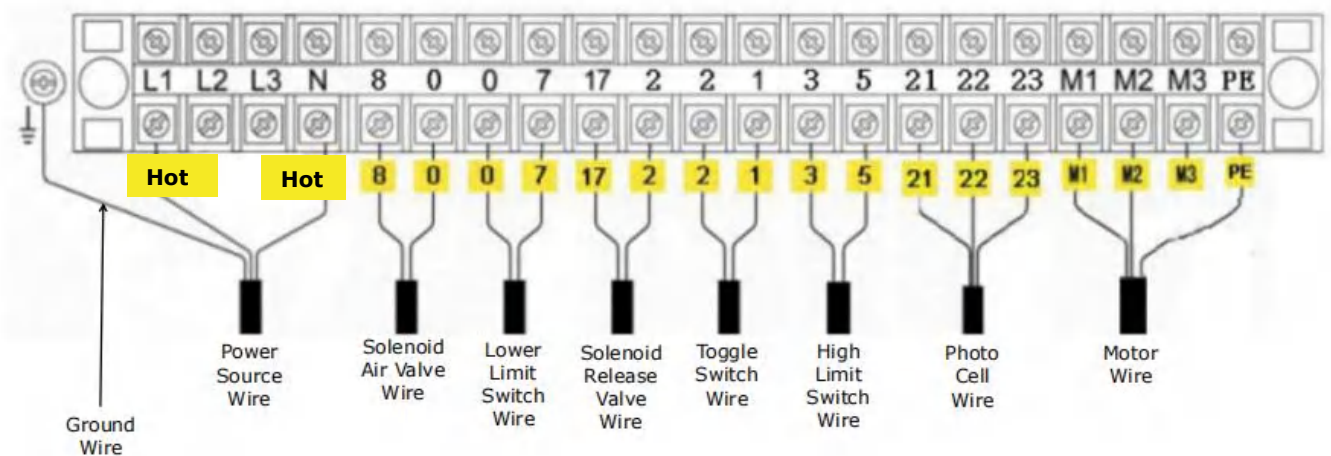

Fig. 17

## 2.2 Single phase Circuit Diagram (See Fig. 18)

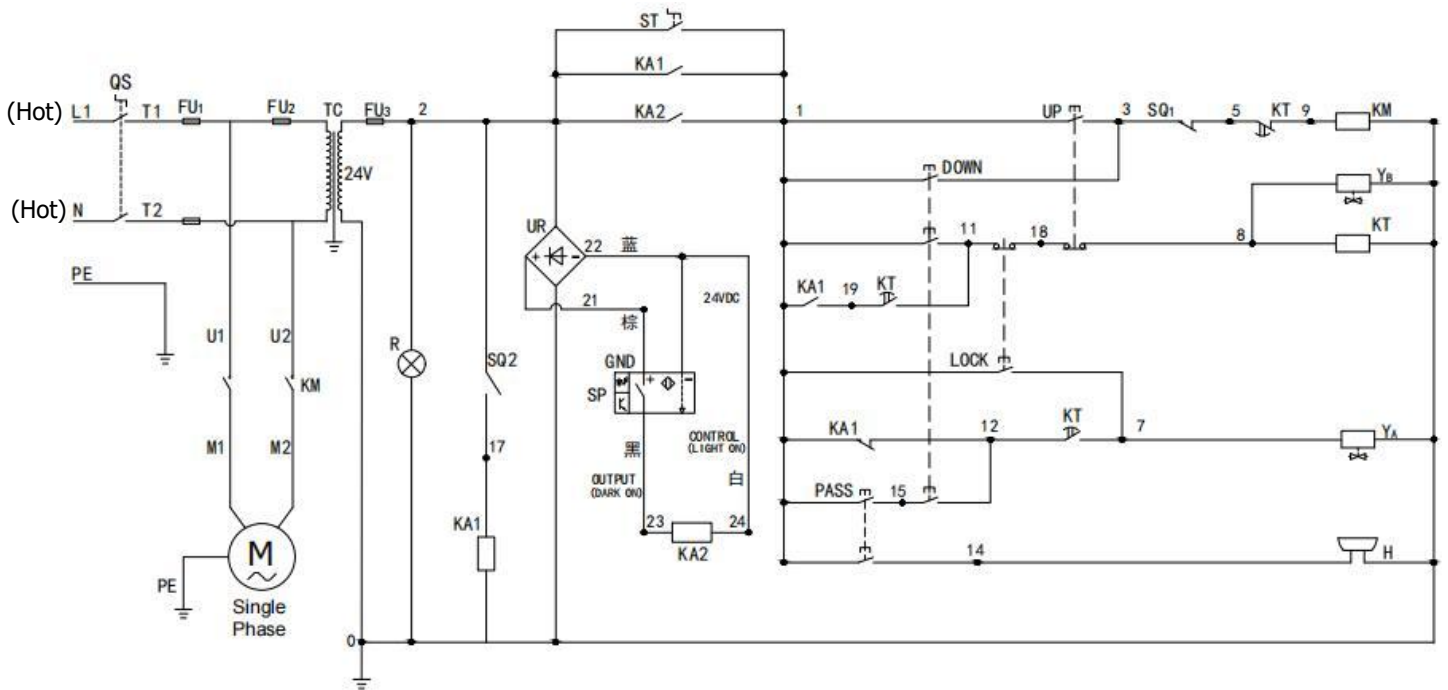

Fig.18

### Electric Component of single phase

Item	Name	Code	Specification
1	Power switch	QS	25A
2	Breaker	FU1	2P
3	Breaker	FU2	1P
4	Breaker	FU3	1P
5	Intermediate Relay	KA2	24V DC
6	Time relay	KT	24V AC
7	Limit switch (High)	SQ1	10A
8	Limit switch (Low)	SQ2	10A
9	Hydraulic solenoid valve	YA	24V AC
10	Air solenoid valve	YB	24V AC
11	Push button	UP	Duplex
12	Push button	Lock	Duplex
13	Push button	Down	Triple
14	Lower alarm button	Pass	Duplex
15	Motor	M	Single phase
16	Buzzer	H	24V AC
17	Transformer	TC	24V AC

18	Intermediate Relay	KA1	24V AC
19	Power indicator	R	White 24V
20	Rectifier bridge	UR	KBPC10-10
21	Photocell	SP	24V DC
22	AC Contactor	KM	24V AC
23	Toggle switch	ST	

**⚠ DANGER** All electrical wiring must be performed by a licensed and certified electrician. Before ensuring the main power has disconnected from the lift and cannot be re-applied until all procedures have been completed, do not perform any maintenance or installation to the lift.

**⚠ DANGER** Do not use the lift if the wires are damaged or severely worn. If the vehicle rises without noticing damage or extreme wear, carefully lower the vehicle to the ground. Once the lift is on the ground, remove it, disconnect the power, and

## IV. Test Run

### A. Prepare for synchronization adjustment

1. Fill reservoir with Hydraulic Oil (**Note: In consideration of power unit's durability, please use Hydraulic Oil 46#**).

### B. Synchronous adjustment

1. Turn on the toggle switch



Turn to "ON" means manual control is turned on, and Photo Cell Switch fails.

**Fig. 19**

2. Lower both platforms to the lowest position.

(Note: synchronous operations must only be carried out at the lift's lowest position.)

3. Turn the Two-way valve to oil filling position (**See Fig.20**).

3.1 Push button **UP** and fill oil to the slave cylinder until P2 platform start to rise.

3.2 Push button **DOWN AND PASS** for 5 seconds to bleed the air, with buzzer sound and bleeding sound from oil tank.

3.3 Repeat above two steps 2-3 times until no air in the hydraulic system .

3.4 The lift is in its lowest state, quickly click button **UP** until the P2 platform just to be lifted up, then loose the button.

4. Turn the Two-way valve to normal working position (**See Fig.21**), push button **UP** to rise the lift. Check if both platforms are at the same height, if not, reply following step, till the two safety devices can be locked or released at the same time (lower the lift to its lowest position before operation).

4.1 If P2 platform lower than P1 platform, turn the Two-way valve to oil filling position (**See Fig.20**). Push button **UP**, rise P2 platform to the same level as P1, then turn the Two-way valve to normal working position (**See Fig.21**).

4.2 If P2 platform lower than P1 platform, turn the Two-way valve to oil filling position. Push button **LOCK**, lower P2 platform to the same level as P1, then turn the Two-way valve to normal working position (**See Fig.21**).

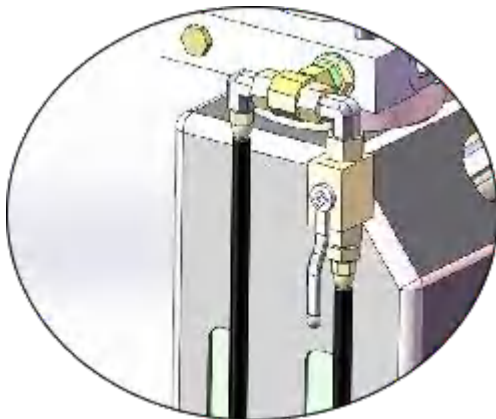

Oil Filling Position

**Fig. 20**

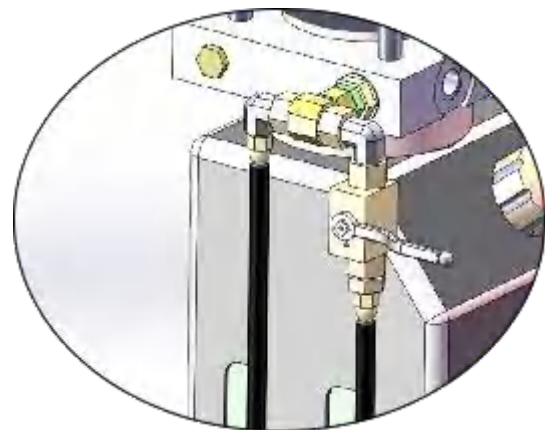

Normal Working Position

**Fig. 21**

5. After platform P1 and P2 run synchronously, turn off the toggle switch to effect the photo cell.

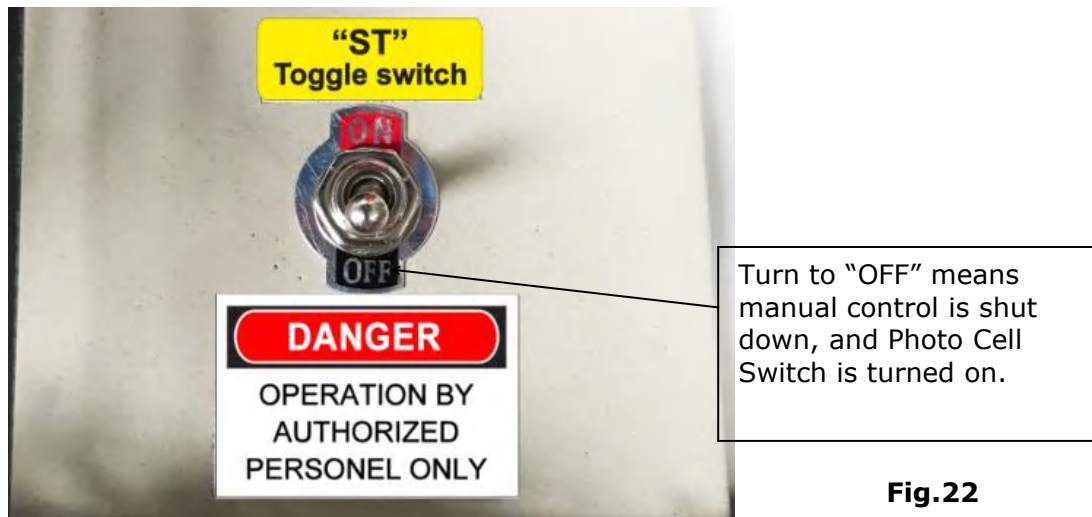
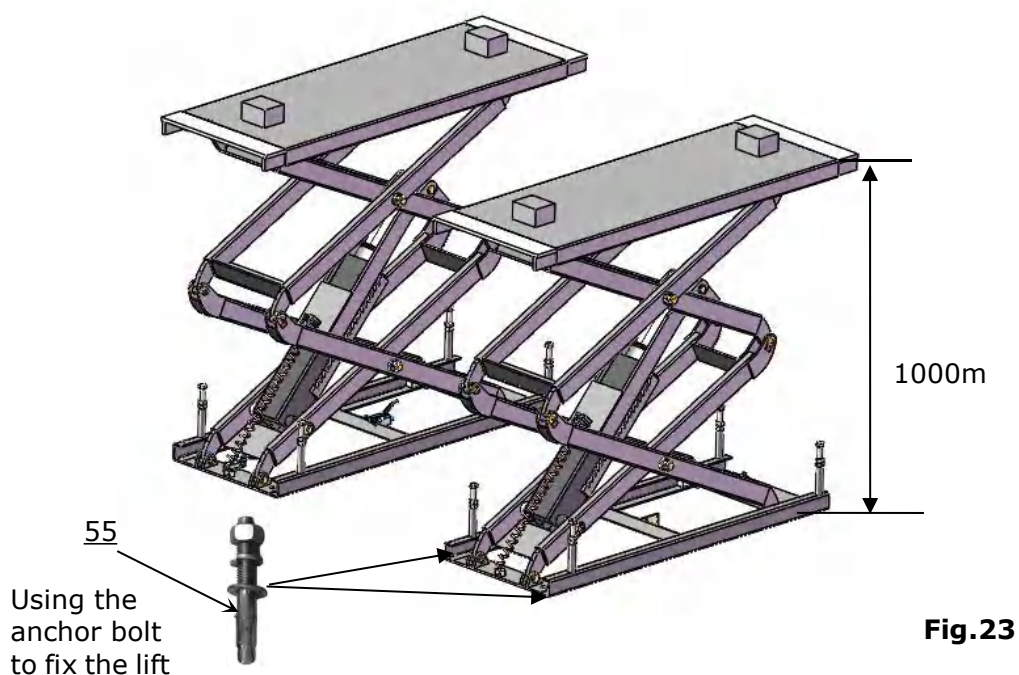

**Fig.22**

Remarks: When the lift is under normal working and platform P1 and P2 become not leveling, the photo cell device starts and cuts off the power. Open the panel of the control cabinet, turn on the toggle switch (see fig 19), the power is on. Reply the above synchronous adjustment again. Then turn off the toggle switch. (see fig.22)

**C. Install anchor bolts and shims**

1. After determining the installation position of the machine and the control cabinet, raise the lift to 1000mm then drill holes to install the anchor bolts.



**Fig.23**

2. Drilling the hole for the anchor bolt(3/4" \* 5-1/2") with the rotary hammer drill, type the anchor bolt into the ground.

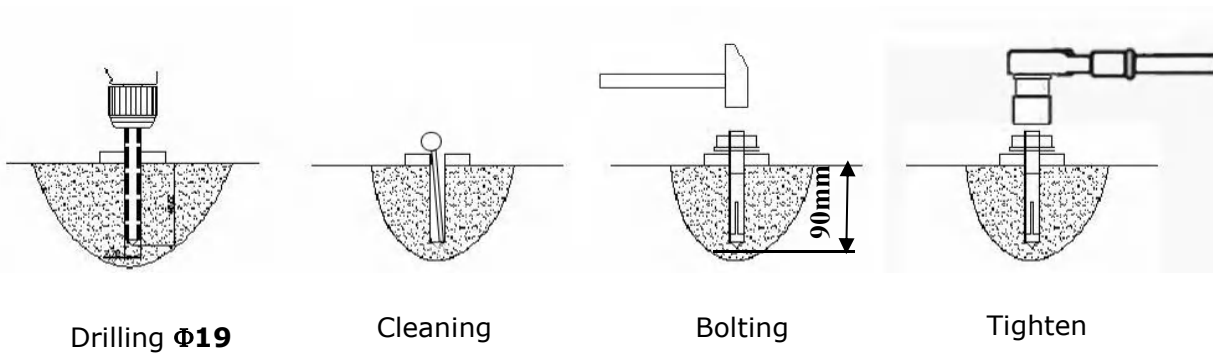

**Fig.24**

**⚠ CAUTION** Concrete and anchor bolts must comply with above specifications. Install lifts only on concrete surfaces. If you are in asphalt or either any other surface on which the lift is mounted, or the concrete or anchor bolts do not meet these specifications, it may result in product damage, vehicle damage, personal injury, or even loss of life.

3. Fix the control cabinet anchor bolts (M10\*100mm), by using  $\Phi 10$  drill.

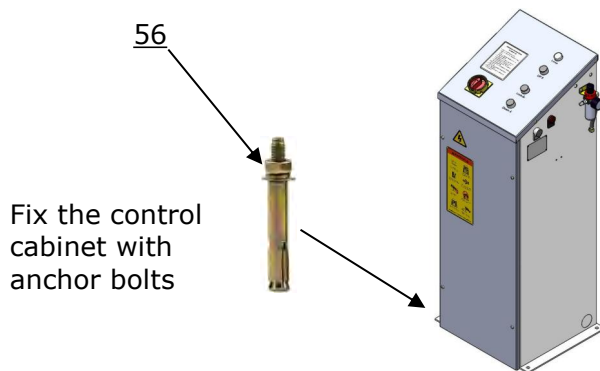

**Fig. 25**

4. Check by level bar and use the shim to adjust the platforms until two platforms are in the same level. Tighten the anchor bolts with spanner after leveling. (**See Fig.26**)

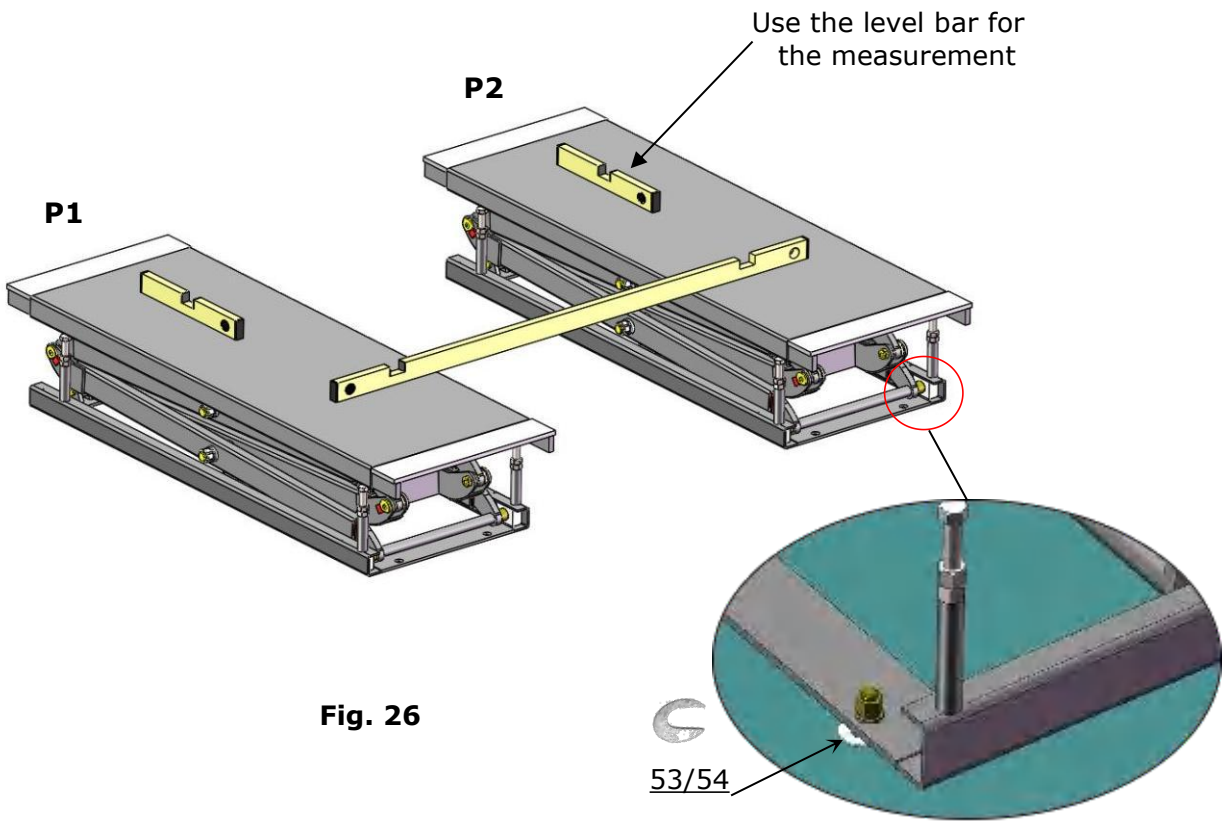

**Fig. 26**

## 5. Test Run

5.1 Check and adjust if necessary the limit switch, oil hoses and air lines connection. If everything is no problem then do test run. The lift must be tested and checked carefully before in use.

### 5.2 Photocell switch illustration

Install photocell switch launcher on the P1 scissors connecting plate and install the reflect panel on the P2 scissors connecting plate (ensure on the inner connecting plate)  
See fig 27.

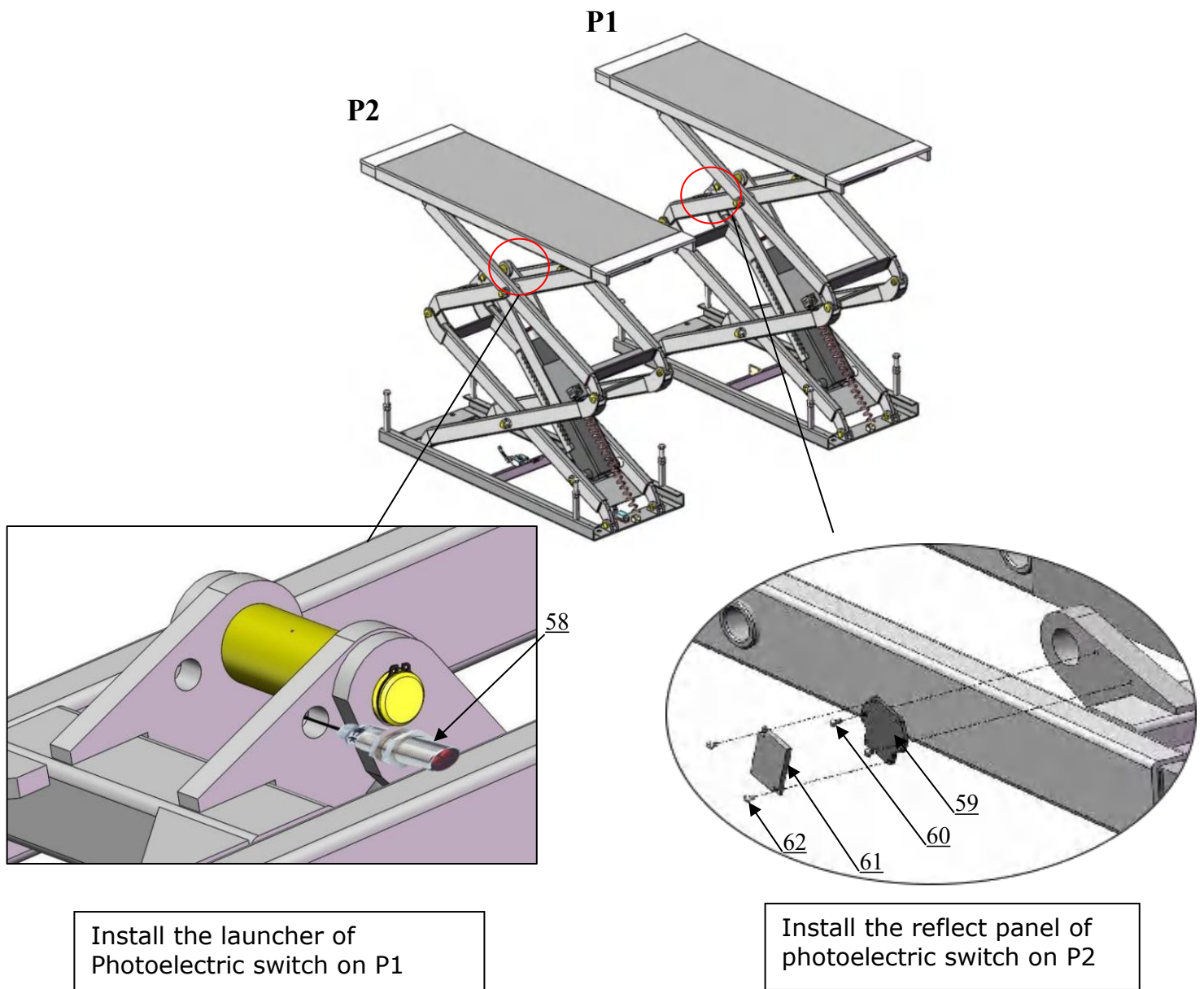

**Fig. 27**

# V. EXPLODED VIEW

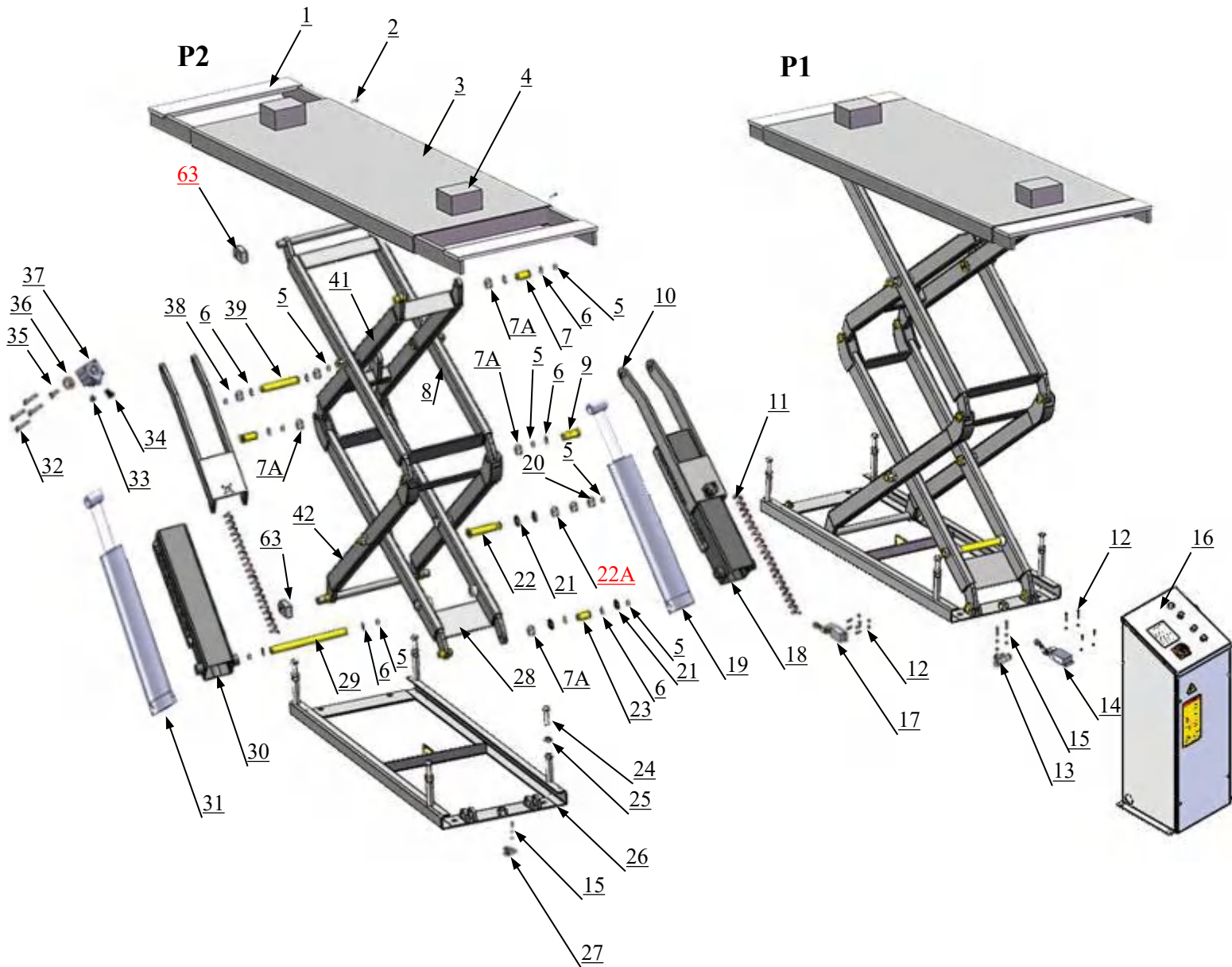

**Fig. 28**

**PARTS LIST FOR XL-10F**

<b>Item</b>	<b>Part No.</b>	<b>Description</b>	<b>QTY</b>
1	11610001A-01	Extendable platform	4
2	10207021	Socket bolt M6*12(with lock washer)	4
3	11610127-01	Platform	2
4	10610070	Rubber pad 120*100*70	4
5	10620064	Greasing Fitting M6	40
6	10610008	Clip ring	24
7	1103313001	Connecting pin	4
7A	1103315003	Bush	16
8	10610006A-04	Upper scissor (out)	2
9	1103112023A-01	Scissors connecting pin	8
10	11610128-01	Safety device support panel	2
11	10520065	Air line L=2000mm	2
12	1003115005	Round head bolt M5*12 (include flat washer)	4
13	10420124	T fitting	1
14	10610119	Low limit switch assy.	1
15	1003115003	Round head bolt M3*20(include flat washer, nut)	3
16	10610129-01	Control cabinet	1
17	10610118	High limit switch assy.	1
18	11610028A-02	Safety lock tube (master)	1
19	C804311-01	Master cylinder	1
20	10610019	Nylok nut M30*3.5	8
21	11610108	Flat washer	20
22	10300802003A	Connecting pin for in/out scissors	8
22A	1003125002	Bush	32
23	1103112022	Connecting pin for base	8
24	86010663	Hex bolt	8
25	10610096	Hex nut M18	8
26	11610017A-03	Base	2
27	10520029	90°Fitting	1
28	11610014C-05	Lower scissor (in)	2
29	11610030A	Fixing pin for cylinder	2
30	11610032A-02	Safety lock tube (slave)	1
31	C804312-01	Slave cylinder	1
32	10420153	Round head bolt M6*20	8
33	10520059	Air cylinder muffle	2
34	10420047	Air cylinder straight fitting	2
35	10680005	Round head bolt M6*10	2
36	10510048	Safety device slider block	2
37	10520011	Air cylinder	2

<b>Item</b>	<b>Part No.</b>	<b>Description</b>	<b>QTY</b>
38	1003205003	Bush	4
39	11610005A-01	Connecting pin for cylinder	2
41	11610011B-05	Upper scissor (in)	2
42	11610013B-04	Lower scissor (out)	2
43	10610114	Airline L=6300mm	1
44	10420145	Oil Water Separator	1
45	1003165007	Round head bolt M6*10 (include nylok nut)	2
46	1004334013	Airline fitting	1
47	1003315002	T fitting for cylinder	1
48	10610068	③ Oil hose assy. L= 82 11/16"	1
49	10610113	② Oil hose assy. L= 174"	1
50	10610112	① Oil hose assy. L= 171 1/4"	1
51	071201	Power unit	1
52	10510023	Straight fitting for cylinder	2
53	10620065	Shim (2mm)	20
54	10201090	Shim (1mm)	20
55	10209059	Anchor bolts 3/4*5-1/2	8
56	10620071	Anchor bolts M10*100	4
57	10610500	Parts box	1
58	10610125	Photocell switch assy.	1
59	11610674-01	Photocell switch fixing plate	1
60	10201104	Round head bolt M4*8	2
61	10610126	Photocell switch reflection plate	1
62	41080181	Round head bot M4*6	2
63	10308103060-01	sliding block	8

## 4.1 Master cylinder **C804311-01**

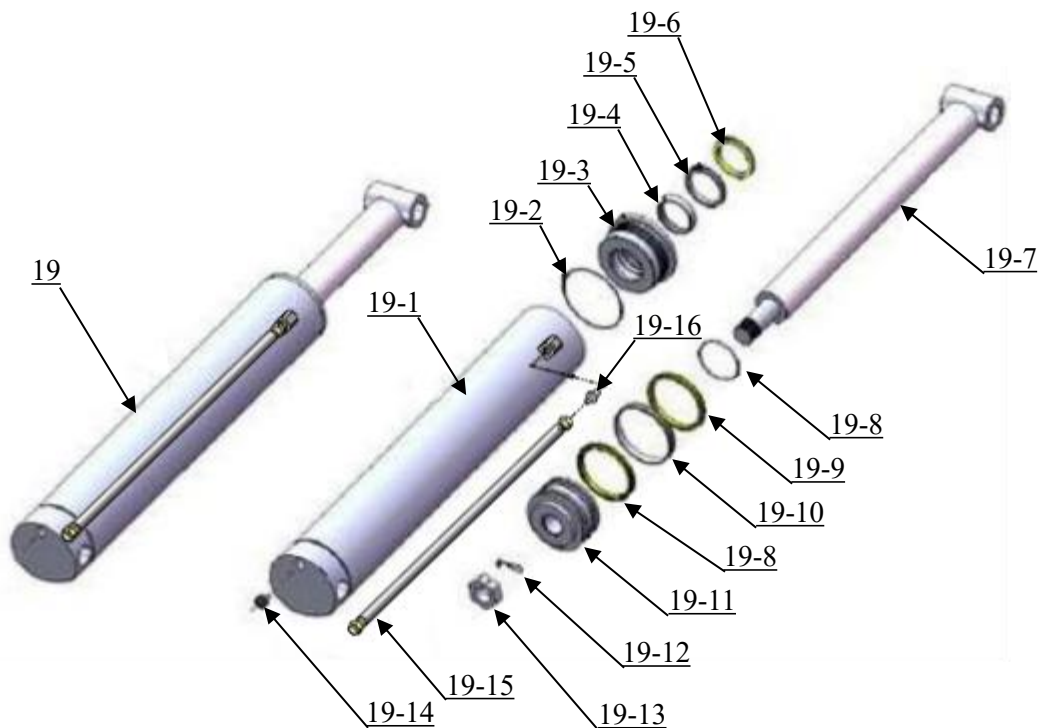
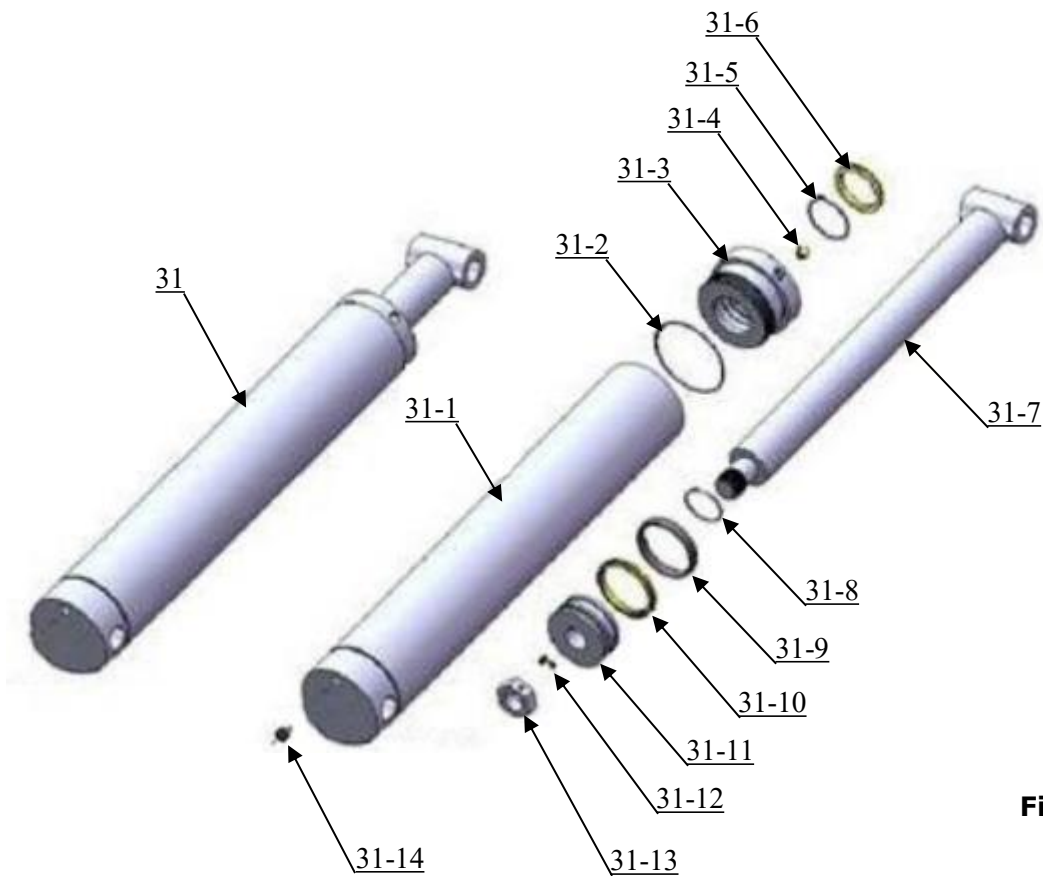

**Fig. 29**

### Parts for Hydraulic Cylinder

Item	Part No.	Description	QTY
19-1	<b>11610033-01</b>	Bore weldment (master)	1
19-2	10520053	O ring	1
19-3	11520043	Head cap (Master)	1
19-4	10520052	Support ring	1
19-5	10520051	Y ring ISI	1
19-6	10520050	Dust ring	1
19-7	<b>11610035-01</b>	Piston rod (Master)	1
19-8	10520054	O ring	1
19-9	10520055	Y ring	2
19-10	10520056	Support ring	1
19-11	11520045	Piston (Master)	1
19-12	10520049	Set screw	1
19-13	10520047	Hex nut (Master) M36	1
19-14	C802007	Anti-explosion valve G3/8-19	1
19-15	1103316001A	Oil hose	1
19-16	10217147	Straight fitting 3/8NPT(M)*3/8JIC(M)	1

## 4.2 Slave cylinder C804312-01



**Fig. 30**

Item	Part No.	Description	QTY
31-1	11610034	Bore weldment (slave)	1
31-2	10510083	O ring	1
31-3	11520044	Head cap (slave)	1
31-4	10201034	Bleeding Plug	1
31-5	10520058	O ring	1
31-6	10520057	Dust ring	1
31-7	11610036-01	Piston rod (slave)	1
31-8	10520061	O ring	1
31-9	10520062	Support ring	2
31-10	10520063	Y ring OSI	1
31-11	11520046	Piston (slave)	1
31-12	10520049	Set screw	1
31-13	10520048	Hex nut (slave) M27	1
31-14	C802007	Anti-explosion valve G3/8-19	1

### 4.3 CONTROL CABINET

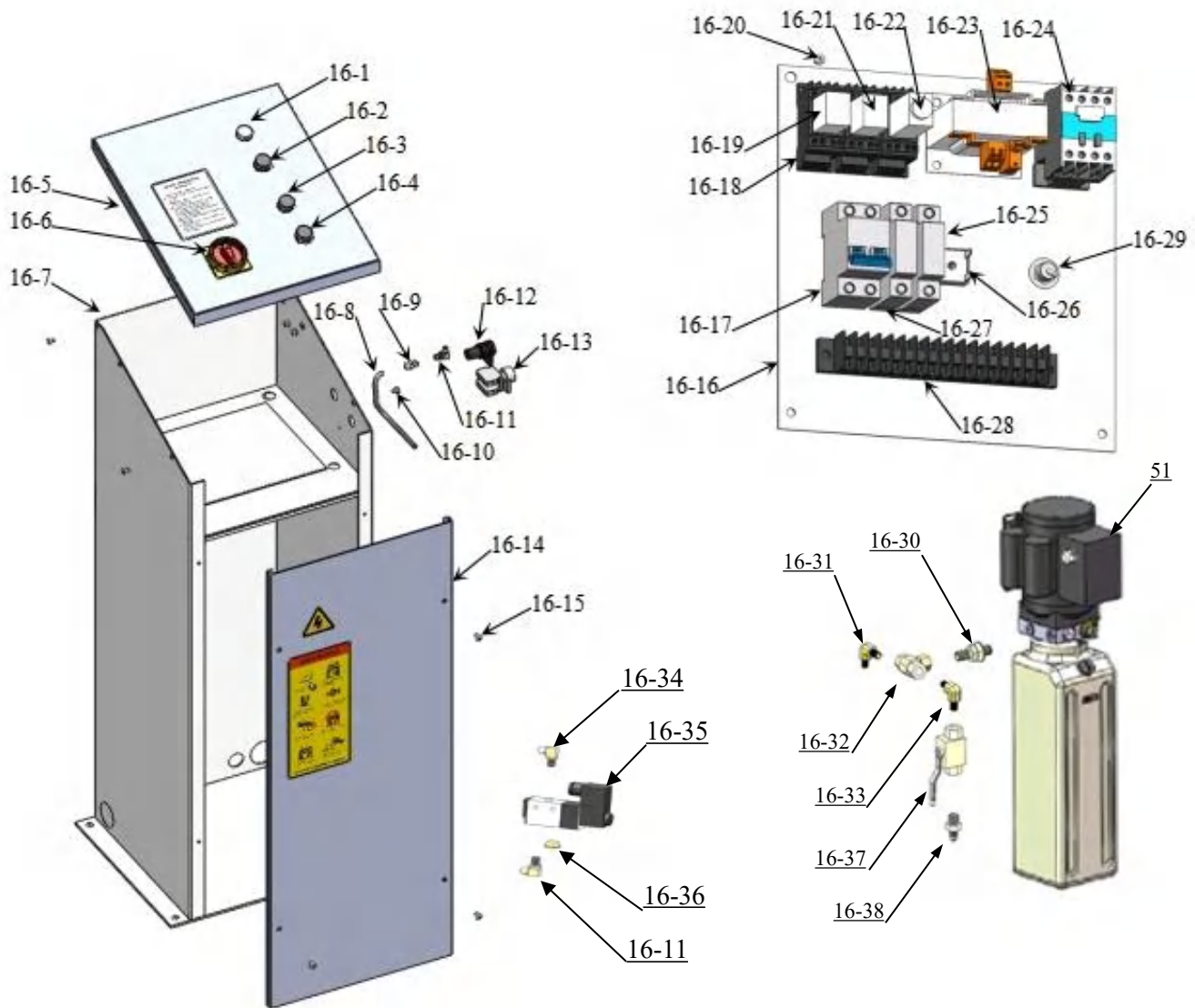

**Fig. 31**

Item	Part No.	Description	QTY
16-1	10201094	Power indicator	1
16-2	10420071	Button UP	1
16-3	10420072	Button DOWN	1
16-4	10420071	Button LOCK	1
16-5	1152K001B	Control Panel	1
16-6	1004187002	Power switch (QS)	1
16-7	11610109	Cabinet	1
16-8	10420167C	Air line L=200mm	2
16-9	1061K110	Straight fitting	1
16-10	10209145	Round head bolt M6*12	4
16-11	10420076	90° Fitting	3
16-12	10420143	Buzzer (H)	1
16-13	10420142	Lower alarm button K	1

<b>Item</b>	<b>Part No.</b>	<b>Description</b>	<b>QTY</b>
16-14	1152K022A	Cabinet door	1
16-15	10720038	Round head bolt M6*30	4
16-16	1152K006A	Terminal Panel for Installing Element	1
16-17	10202046	Breaker 2P	1
16-18	10420135	Timer Relay Base	1
16-19	10420141	Intermediate Relay	1
16-20	1061K052	Round Head Bolt with washer M4*8	17
16-21	1041010492	Intermediate Relay	1
16-22	10420083	Timer Relay	1
16-23	10580114	Transformer	1
16-24	10420084A	AC Contactor	1
16-25	10510081	Breaker 1P	1
16-26	10580101	Rectifier bridge	1
16-27	10510081	Breaker 1P	1
16-28	10620082	Terminal connector	1
16-29	10580100	Toggle switch	1
16-30	10440009	Straight fitting 3/8"SAE <sup>0/R</sup> (M)*1/4"NPT(M)	1
16-31	10420097	90° fitting 1/4NPT(M)*1/4"JIC(M)	1
16-32	1061K107	T fitting 1/4NPT(F)*1/4NPT(F)*1/4NPT(F)	1
16-33	10680072	90° fitting 1/4"NPT(M)*1/4"NPT(M)	1
16-34	10420166	90°fitting	1
16-35	10420077	Solenoid air valve (3V210-08-NC AC24V)	1
16-36	10201034	Muffler	1
16-37	1003105005	Two-way valve	1
16-38	10209064	Straight fitting 1/4"NPT(M)*1/4"JIC(M)	1

#### 4.4 Illustration of hydraulic valve for electric power unit

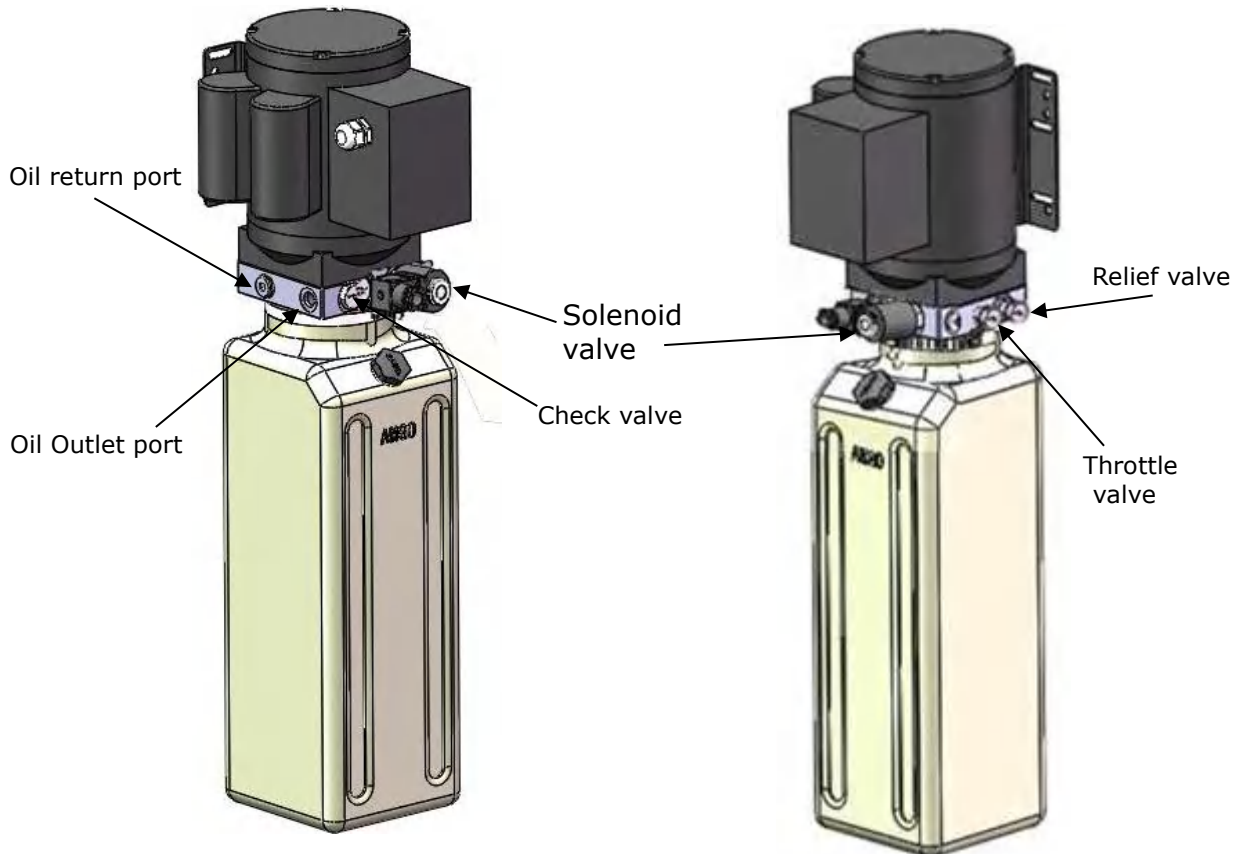

Fig.32

## VI. OPERATION INSTRUCTIONS

### To lift vehicle

1. Keep clean of site near the lift, and down the lift to the lowest position.
2. Drive vehicle to the platform and put on the brake.
3. Turn on the power and push the button **UP**, raise the lift to the working position.  
**Note:** make sure the vehicle is steady when the lift is rising
4. Push button **LOCK** to lock the lift in the safety device. Make sure the safety is locked in the same height before working.

**⚠️ WARNING** It is unsafe to work under the lift without locking at the safety device after it has been lifted up, which may causes vehicle fall, damage, lift damage, human injury or even death.

## To lower vehicle

1. Be sure clear of around and under the lift, only leaving operator in lift area.
2. Turn on the power switch, push the button “Down” , the lift is lowered continually and stopped at the height 500mm from ground. Keep feet clear off lift, push button “DOWN” while push the lower alarm button “Pass” at the side of control cabinet, the lift is lowered to ground with alarm tone;
3. Drive away the vehicle when the lift is lowered to the lowest position.
4. Turn off the power, clean the lift’s appearance, clean the work site.

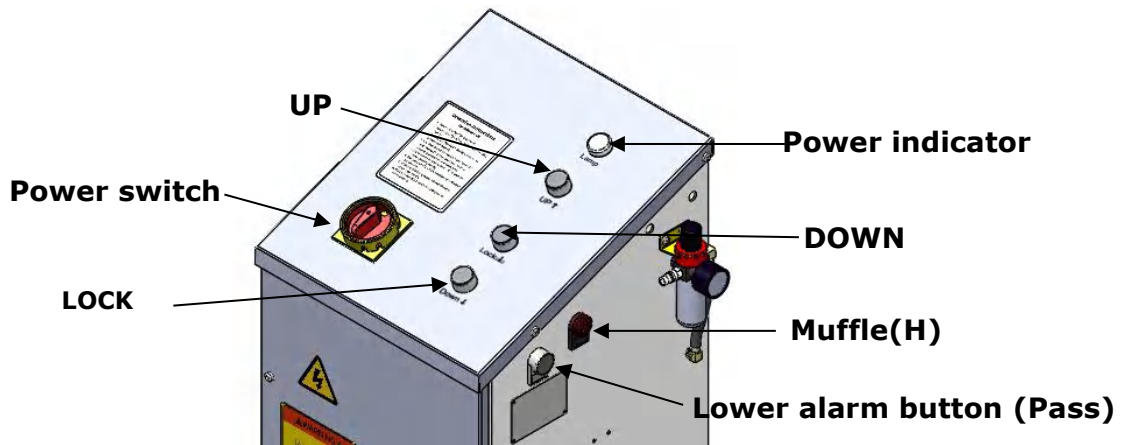

Fig. 33

## VII.MAINTENANCE SCHEDULE

### Monthly:

1. Re-torque the anchor bolts to 150 Nm.
2. Lubricate all moving parts with lubricant.
3. Check all fittings, bolts and pins to insure proper mounting.
4. Make a visual inspection of all hydraulic hoses/lines for possible wear or leakage.
5. Adjusting the lifting level on both platforms.

**Note:** All anchor bolts should take full torque. If any of the bolts does not function for any reason, **DO NOT** use the lift until the bolt has been replaced.

### Every six months:

1. Make a visual inspection of all moving parts for possible wear, interference or damage.
2. Check and adjust the platform as necessary to insure level lifting.
3. Check all fastener and re-torque.

**Oil cylinder maintenance:**

In order to extend the service life of the oil cylinder, please operate according to the following requirements.

1. Recommend to use N46 anti-wear hydraulic oil.
2. The hydraulic oil of the lifts should be replaced regularly during using.  
Replace the hydraulic oil 3 months after the first installation, Replace the hydraulic oil once a year afterwards.
3. Make at least one full trip raising and lowering per day. For exhausting the air from the system, which could effectively avoid the corrosion of the cylinder and damage to the seals caused by presence of air or water in the system.
4. Protect the outer surface of the oil cylinder's piston rod from bumping and scratching, and timely clean up the debris on the oil cylinder dust-ring and the piston rod.

## VIII.TROUBLE SHOOTING

TROUBLE	CAUSE	REMEDY
Motor does not run	<ol style="list-style-type: none"> <li>1.Button does not work</li> <li>2. AC contactor burned out</li> <li>3. Motor burned out</li> </ol>	<ol style="list-style-type: none"> <li>1. Replace button</li> <li>2. Replace AC contactor</li> <li>3. Repair or replace motor</li> </ol>
Motor have voice but not run	<ol style="list-style-type: none"> <li>1.Wiring connections of 3 phase are not in good condition.</li> <li>2. AC contactor main contacts in poor contact</li> </ol>	<ol style="list-style-type: none"> <li>1. Check the 3 phase wiring connections, and repair it if not in good condition.</li> <li>2. Replace AC contactor.</li> </ol>
Motor runs but the lift is not raised	<ol style="list-style-type: none"> <li>1.Motor runs in reverse rotation</li> <li>2.Low oil level</li> <li>3.The Gear Pump out of operation</li> <li>4.Relief valve or check valve in damage</li> <li>5.Shaft Coupling in damage</li> </ol>	<ol style="list-style-type: none"> <li>1.Reverse two power wire</li> <li>2.Fill tank</li> <li>3.Repair or replace</li> <li>4.Repair or replace</li> <li>5.Replace Shaft Coupling</li> </ol>
Lift raised slowly	<ol style="list-style-type: none"> <li>1.Oil line is jammed</li> <li>2. Gear Pump leaks</li> <li>3.Overload lifting</li> <li>4.Power Voltage low</li> <li>5.Oil mixed with air</li> </ol>	<ol style="list-style-type: none"> <li>1.Clean the oil line</li> <li>2.Replace Pump</li> <li>3.Check load</li> <li>4.Check electrical system</li> <li>5.Fill tank and bleeding air</li> </ol>
Lift cannot lower	<ol style="list-style-type: none"> <li>1. Hydraulic Solenoid valve out of operation</li> <li>2. Low Air pressure can't open the lock</li> </ol>	<ol style="list-style-type: none"> <li>1. Check Solenoid valve and Air line</li> <li>2.Adjusting Air pressure of Compressor</li> </ol>

## IX. CAR LIFT SAFETY TIPS

Put this safety tips in a place where you can always alert the operator. Please reference to the lift manufacturer's manual for specific information about the lift.

1. Check the lift daily. If the machine breaks down or has damaged parts, do not operate, and use original equipment parts to repair.
2. **Do not** overload . The rated weight of the manufacturer design is indicated on the label of the lift.
3. Position control of the vehicle and operation of the lift can only be done by a trained and authorized person.
4. **Do not** lift a car with occupants inside. Keep the customers or bystanders away from the lift.
5. Keep the area around the lift free of obstacles, lubricating oil, grease, garbage and other debris for a long time.
6. Carefully drive the vehicle onto the lift and lifting up to the required height for operation. **Noted:** lift it high enough if you are working underneath, and make sure the safety devices are locked.
7. **Noted:** removing( install) parts from(to) a vehicle would cause a sudden shift of gravity which may result in instability of the vehicle. Please refer to the vehicle manufacturer's service manual as a recommended procedure if you need remove/install parts from(to) the vehicle
8. Before lowering the lift , make sure all obstacles underneath, include tool tray, tool rack etc., are all removed.

## X. LIFT DISPOSAL

When the car lift cannot meet the requirements for normal use and needs to be disposed, it should follow local laws and regulations.



**Address:**

SC Division: 1931 Joe Rogers Jr Blvd, Manning, SC 29102, USA

TX Division: 4310 Adler Dr., Suite #200, Dallas, TX 75211, USA

<http://www.amgohyd.com>

Manual No.: **72268608**  
Revision Date: **2026/05**