

ROLLING JACK

Designed to handle loads ranging from 5,000lbs to an impressive 20,000lbs, our industry-leading rolling jacks transform your four-post lift or scissors lift into a fully-fledged workstation, delivering unparalleled performance and efficiency. Designed for universal compatibility, they seamlessly integrate with all major car lift brands, giving you the versatility to tackle any job with confidence.

**J5H
RJ-6H
RJ-6A
RJ-8A
RJ-10A
RJ-20A**

MANUAL HYDRAULIC & PNEUMATIC HYDRAULIC



FEATURES

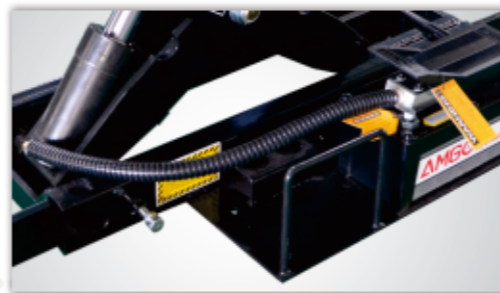

▲ Engineered to a high standard, the cylinder features high-quality oil seals and high-pressure oil hoses to provide durable, efficient hydraulic performance.



▲ An easy-to-operate manual control safety lock device with multiple lock positions ensures a secure and comfortable working height.



▲ The guardrail is designed to make sure the jack moves smoothly and protects the oil hoses.



▲ The telescoping arms make this jack compatible with a wide range of vehicles and the adjustable lower sliding assembly works with most four post and scissor lifts on the market.

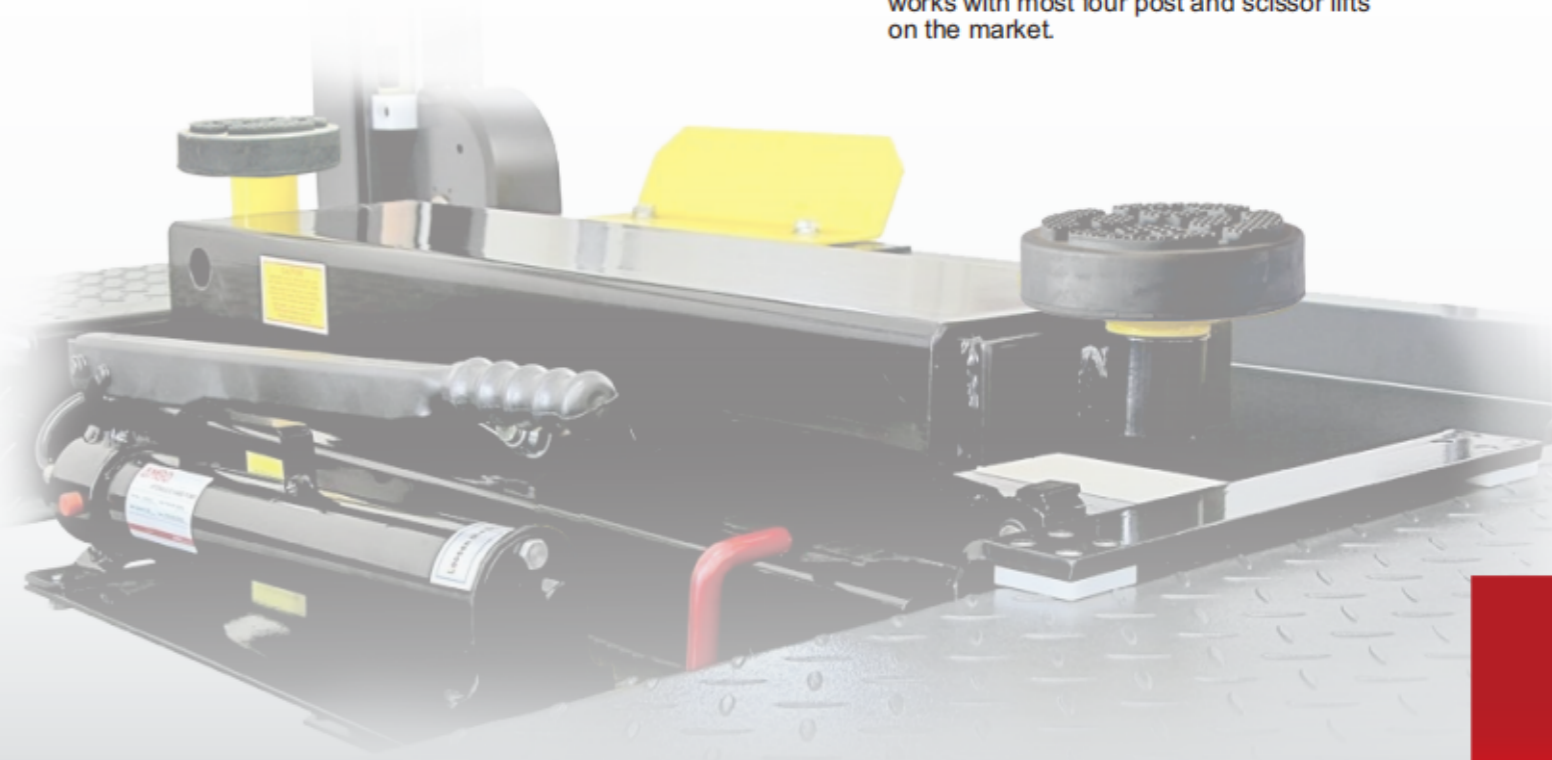

AMGO HYDRAULIC CORPORATION

SC Division: 1931 Joe Rogers Jr Blvd, Manning, SC 29102, USA
Tel: (803) 505-6410

TX Division: 4310 Adler, Suite 200, Dallas, TX 75211, USA
Tel: (214) 377-8091

MODEL J5H 5,000lbs

J5H is the ideal jack solution for a lift with no rails on the runways, such as our parking lift models. With a capacity of 5,000lbs, this jack can be used to service a large number of vehicles daily. The hand pump eliminates the need for an air source, making it versatile

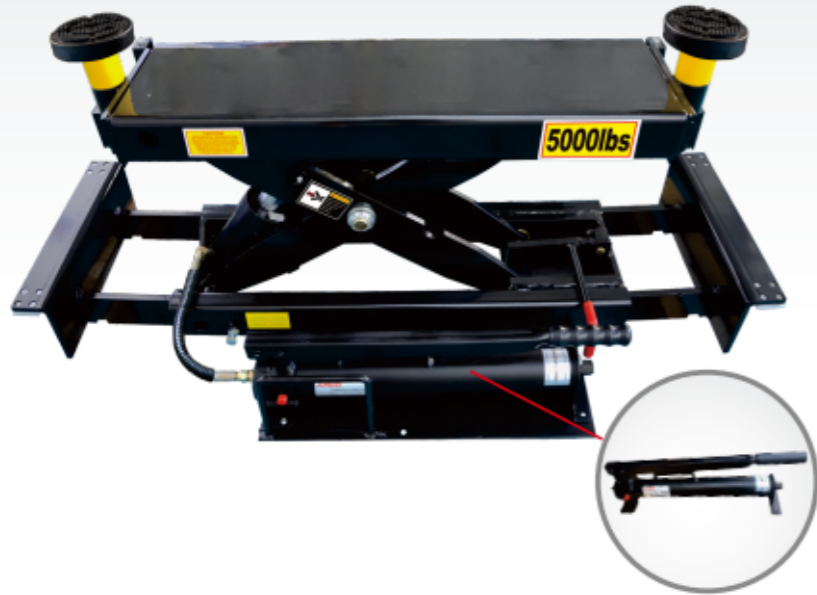

The commercial-grade manual pump is easy to use and requires no additional air source

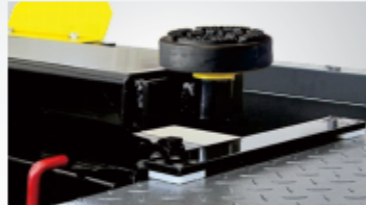

Extendable lower sliding assembly with plastic sliders that support the easy, smooth movement of the jack.



Drop in rubber pads with 2.5" extension adapters.

FEATURES

- Equipped with commercial-grade manual hydraulic pump (no air source required).
- Drop in rubber pads and 2.5" extension adapters come standard.
- Extendable arms allow for easy positioning at the recommended support points.
- Manual safety locks with two locking positions ensure a comfortable working height.
- The extendable lower sliding assembly offers excellent compatibility with products from various brands.
- The ergonomic guardrail doubles as a booster handle, making it easy to move the jack while protecting the oil hose.

MODEL RJ-6H 6,000lbs

The RJ-6 Series rolling jack has a low-profile design and a lifting capacity of 6,000lbs. This makes it ideal to pair with any four-post or scissors lift with a capacity of no more than 12,000lbs. The floating patented technology has been developed to enhance the smooth movement on the rail and ensure a stable, secure fit in the groove when lifting a vehicle.

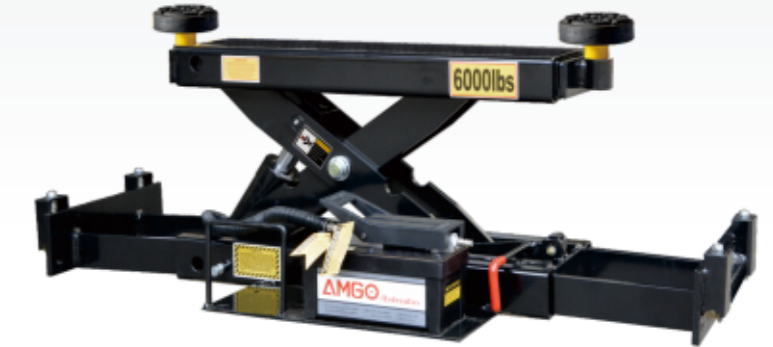

Patented floating system allows the jack to glide smoothly on the rail and has a stable, secure fit in the groove when lifting a vehicle.
Patent no.: 2022231181200.



The commercial-grade manual pump is easy to use and requires no additional air source. (RJ-6H only).



提取文字 更多



Pneumatic hydraulic pump equipped with a high-pressure, extended-life hose (RJ-6A only).

FEATURES

- Equipped with commercial-grade hydraulic pump: pneumatic (J6A) and manual (J6H).
- Drop in rubber pads and 2.5" extension adapters come standard.
- Extendable arms allow for easy positioning at the recommended support points.
- Manual safety locks with two locking positions ensure a comfortable working height.
- The extendable lower sliding assembly offers excellent compatibility with products from various brands.
- The ergonomic guardrail doubles as a booster handle, making it easy to move the jack while protecting the oil hose.
- Patented floating system ensures the jack move smoothly on the rail and sit stably in the groove when lifting a vehicle.

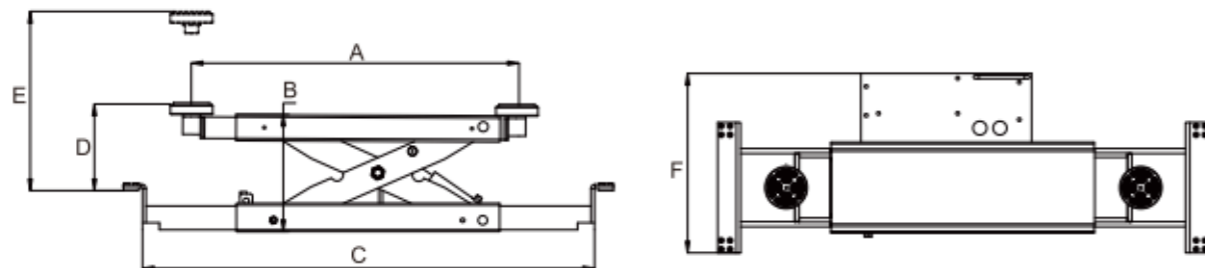

SPECIFICATIONS

Model	Lifting Capacity	Lifting Time	A		C	D	E		F	Gross Weight	Air Pressure	Pump
			Arm Pads Reach	Min Height			Without adapters	With adapters				
J5H	5,000lbs	50S	33 1/8"-53 7/16"	8 11/16"	35 5/8"-50 3/16"	5 1/16"	14"	169 1/16"	20 1/16"	273lbs	/	Manual Pump
RJ-6H	6,000lbs	50S	33 1/16"-53 7/16"	8 1/2"	33 3/8"-52 3/8"	8 5/8"	17 3/4"	20 1/4"	20 1/16"	280lbs	/	Manual Pump
RJ-6A	6,000lbs	50S	33 1/16"-53 7/16"	8 1/2"	33 3/8"-52 3/8"	8 5/8"	17 3/4"	20 1/4"	20 1/16"	280lbs	0.8Mpa	Pneumatic Pump

The images, technical specifications, and descriptions shown here are subject to change without prior notice. Please contact us for the latest information if necessary.

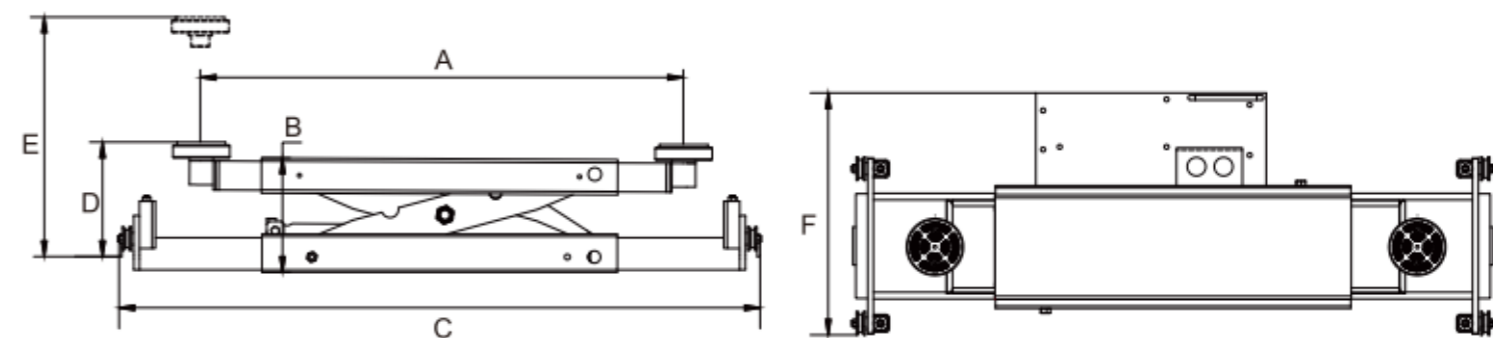

MODEL RJ-8A 8,000lbs

MODEL RJ-10A 10,000lbs

MODEL RJ-20A 20,000lbs

The RJ-8A and RJ-10A are excellent options for commercial workshops serving a wide range of vehicles, including sports cars, pickups and heavy-duty trucks. The product's heavy-duty structure features telescoping arms and floating patent technology for versatility, adaptability and powerful performance.



▲ Patented floating system allows the jack to glide smoothly on the rail and has a stable, secure fit in the groove when lifting a vehicle.
Patent no. 2022231181200.

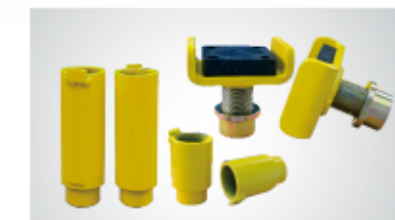

▲ Heavy-duty single-screw frame saddle pads packaged with 3" & 6" extension adapters.



▲ Patented floating system allows the jack to glide smoothly on the rail and has a stable, secure fit in the groove when lifting a vehicle.
Patent no. 2022231181200.



▲ Drop in rubber pads with 2.5" and 5" extension adapters.



▲ Pneumatic hydraulic pump equipped with a high-pressure, extended-life hose.

FEATURES

- Equipped with commercial-grade pneumatic hydraulic pump.
- Whole set of drop in rubber pads, 1.5" and 2.5" extension adapters comes standard.
- Telescoping extendable arms allow for easy positioning at the recommended support points.
- Manual safety locks with two locking positions ensure a comfortable working height.
- The extendable lower sliding assembly offers excellent compatibility with products from various brands
- The ergonomic guardrail doubles as a booster handle, making it easy to move the jack while protecting the oil hose.
- Patented floating system ensures the jack move smoothly on the rail and sit stably in the groove when lifting a vehicle.

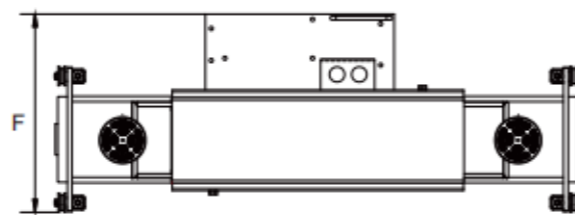
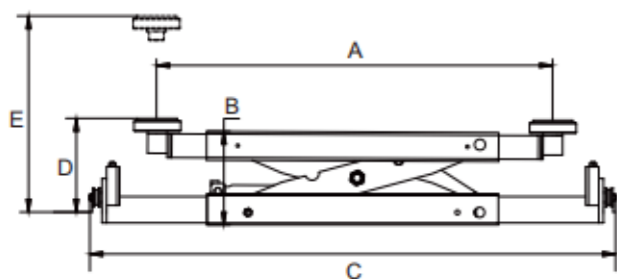

FEATURES

- Equipped with a heavy-duty pneumatic hydraulic pump.
- Single-screw heavy-duty saddle adapters provide a better chassis engagement and secure support.
- 3" and 6" extension adapters come standard.
- Reinforced heavy-duty scissors allow a more secure lift.
- Heavy-duty extendable arms allow for positioning at the recommended support points.
- Manual safety locks with two locking positions ensure a comfortable working height.
- The extendable lower sliding assembly offers excellent compatibility with products from various brands.
- The ergonomic guardrail doubles as a booster handle, making it easy to move the jack while protecting the oil hose.
- Patented floating system ensures the jack move smoothly on the rail and sit stably in the groove when lifting a vehicle.

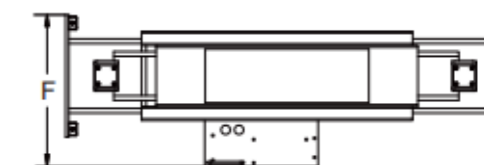
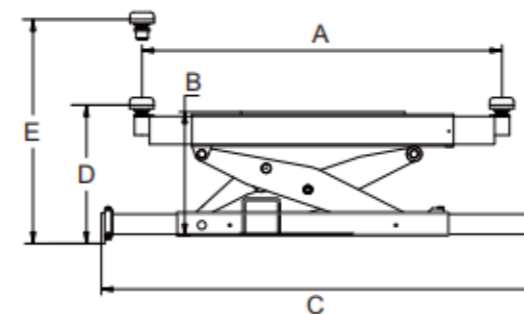

SPECIFICATIONS

Model	Lifting Capacity	Lifting Time	A	B	C	D	E		F	Gross Weight	Air Pressure	Pump
			Arm Pads Reach	Min. Height	Support Base Width	Min. rubber pad Height	Max. lifting height Without adapters	Max. lifting height With adapters				
RJ-8A	8,000lbs	50S	34 7/16"~56"	10 11/16"	36"~56 1/2"	10 7/8"	21 3/16"	28 11/16"	21 3/4"	397lbs	0.8Mpa	Manual Pump
RJ-10A	10,000lbs	50S	34 5/8"~62 3/8"	11"	36"~56 1/2"	11 3/16"	21 1/2"	29"	21 3/4"	467lbs	0.8Mpa	Manual Pump
RJ-20A	20,000lbs	50S	45 1/4"~66 1/8"	14 3/16"	45 3/16"~58 1/4"	16 9/16"~17 15/16"	31"~32 5/16"	40"~41 5/16"	25 1/2"	829lbs	0.8Mpa	Manual Pump

The images, technical specifications, and descriptions shown here are subject to change without prior notice. Please contact us for the latest information if necessary.