

Installation And Service Manual

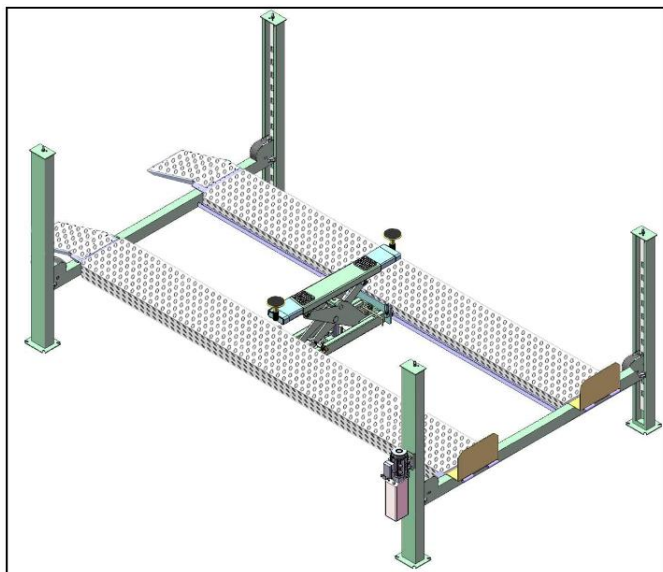

PRO-12SX

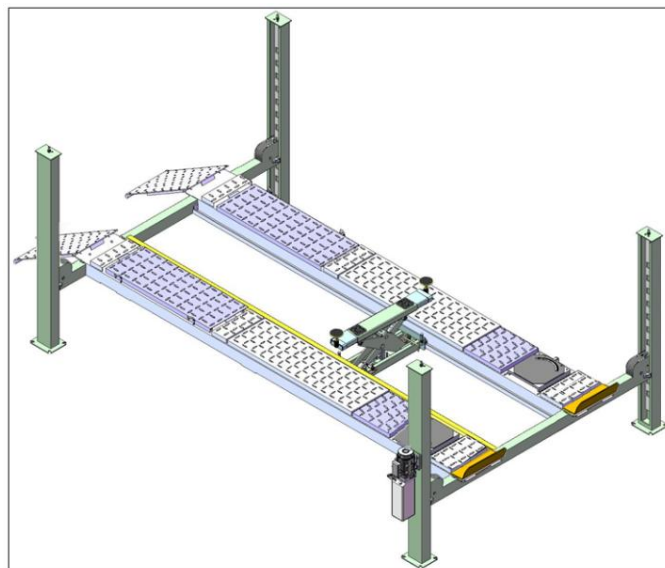

PRO-12ASX

FOUR-POST LIFT
Model: PRO-12SX
PRO-12ASX

CONTENTS

Product Features and Specifications	1
Installation Requirement	2
Steps of Installation	4
Exploded View	22
Test Run	30
Operation Instruction	31
Maintenance	31
Trouble Shooting	33
Lift Disposal.....	33

I. PRODUCT FEATURES AND SPECIFICATIONS

FEATURES

- Manual-air control operation system.
- Mechanical self-lock and air-driven safety release.
- Manual hydraulic power system, cable-driven.
- Non-skid diamond platforms.
- Adjustable platform and adjustable safety lock ladders.
- Optional Jack: With hand pump/Air-operated hydraulic pump/Controlled by power unit.
- Optional Turnplates: (only for PRO-12ASX)

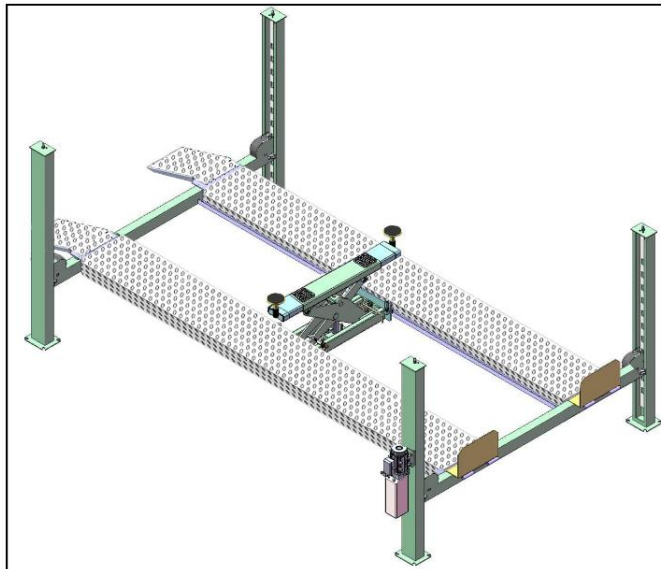

**PRO-12SX
Fig.1**

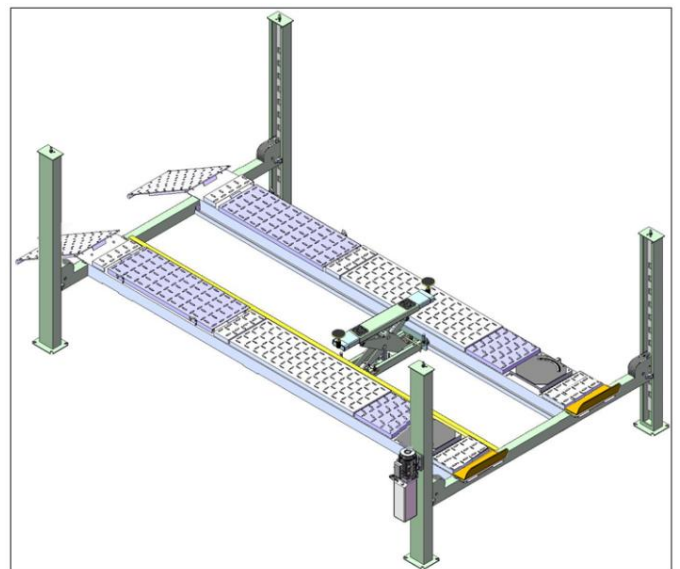

**PRO-12ASX
Fig.2**

MODEL PRO-12S(AS) SPECIFICATIONS

Model	Lifting Capacity	Lifting Height	Lifting Time	Overall Length (Inc. Ramps)	Overall Width	Width Between Columns	Motor
PRO-12SX	12000lbs	73-1/2"	45S	237-5/8"	132-1/8"	118-1/8"	2.0HP
PRO-12ASX	12000lbs	75-3/8"	45S	237-5/8"	132-1/8"	118-1/8"	2.0HP

II. INSTALLATION REQUIREMENT

A. TOOLS REQUIRED

- ✓ Rotary Hammer Drill ($\Phi 3/4''$)



- ✓ Hammer



- ✓ Level Bar



- ✓ English Spanner (12")



- ✓ Wrench Set (10#, 12#, 13#, 14#, 17#, 19#, 24#, 30#)



- ✓ Ratchet Spanner with Socket (28#)



- ✓ Carpenter's Chalk



- ✓ Screw Sets



- ✓ Tape Measure (7.5m)



- ✓ Pliers



- ✓ Lock Wrench



- ✓ Socket Head Wrench (3#, 5#, 6#)



Fig. 3

B. Equipment storage and installation requirements.

The equipment should be stored or installed in a shady, normal temperature, ventilated and dry place.

C. The equipment should be unload and transfer by forklift. (See Fig.4)



Fig. 4

D. SPECIFICATIONS OF CONCRETE (See Fig. 5)

Specifications of concrete must be adhered to the specification as following.

Failure to do so may result in lift and/or vehicle falling.

1. Concrete must be thickness 4” minimum and without reinforcing steel bars, and must be dried completely before the installation.
2. Concrete must be in good condition and must be of test strength 3,000psi (210kg/cm²) minimum.
3. Floors must be level and no cracks.

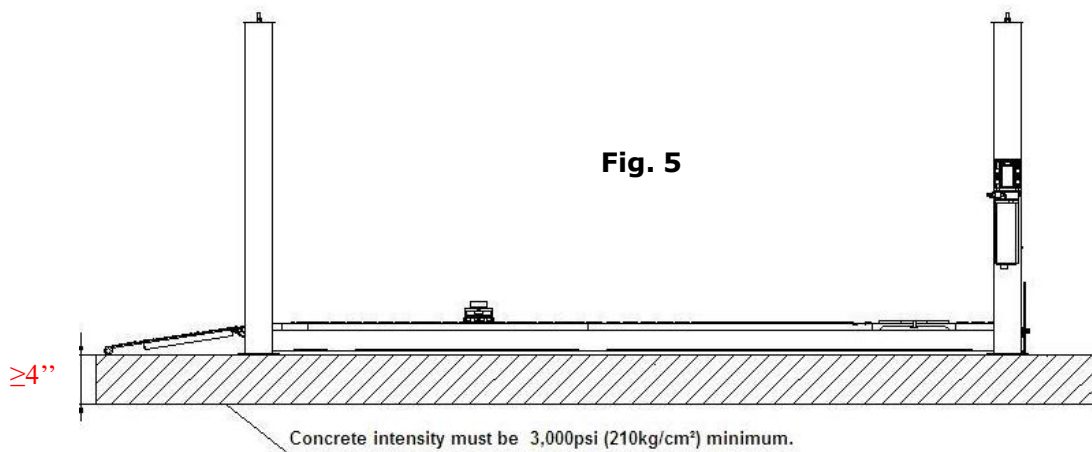

E. AIR SUPPLY

Air pressure requirement: 0.8Mpa, Air line size $\phi 8 \times \phi 6$ and $\phi 6 \times \phi 4$.

F. POWER SUPPLY

The electrical source must be 2HP minimum. The source cable size must be 2.5mm² and in good condition of contacting with floor.

III. STEPS OF INSTALLATION

A. Location of installation

Check and insure the installation location (concrete, layout, space size etc.) is suitable for lift installation.

B. Check the parts before assembly

1. Packaged lift and hydraulic power unit (See Fig. 6).



Fig. 6

2. Open the outer packing carefully (See Fig. 7).

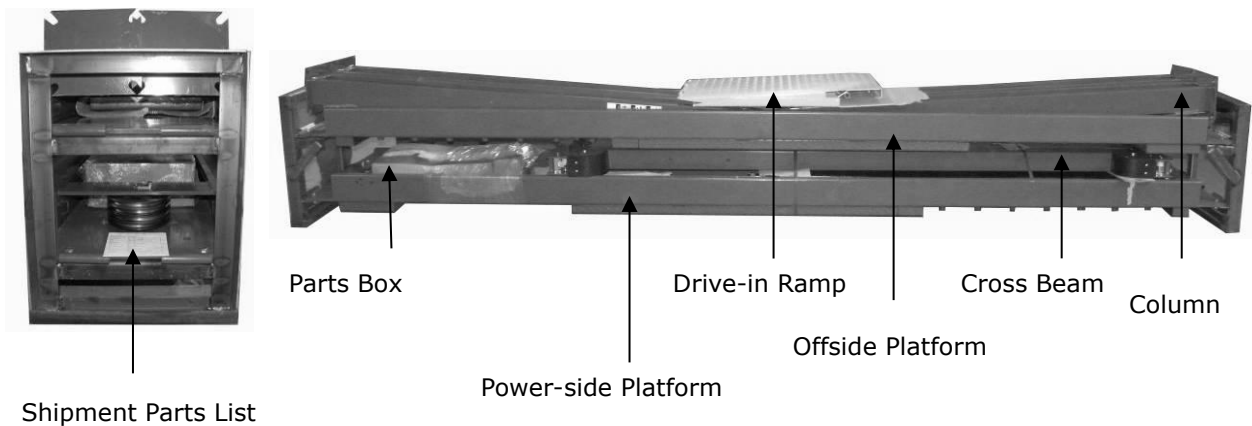

Fig. 7

3. Take off the drive-in ramps and columns (See Fig. 8).



Fig. 8

4. Loose the screws of the upper package stand, take off the offside platform, take out the parts inside the power-side platform, then remove the package stand.

5. Move aside the parts and check the parts according to the shipment parts list
(See Fig. 9).

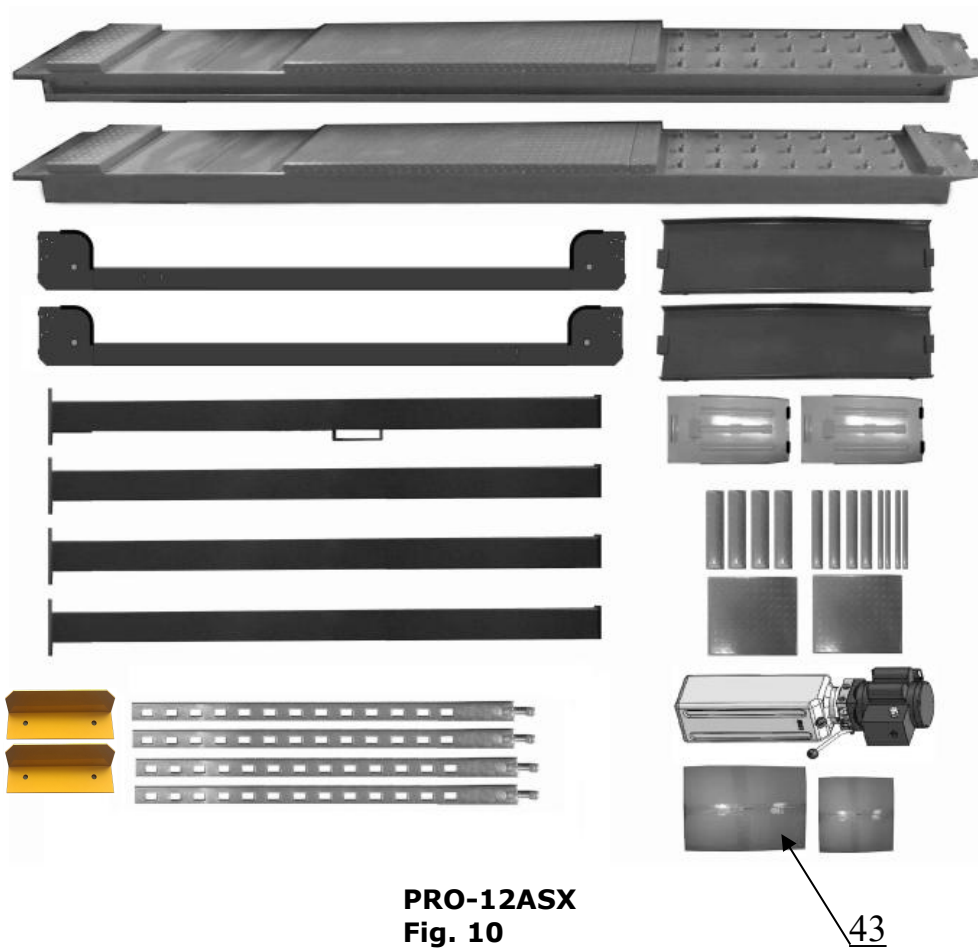
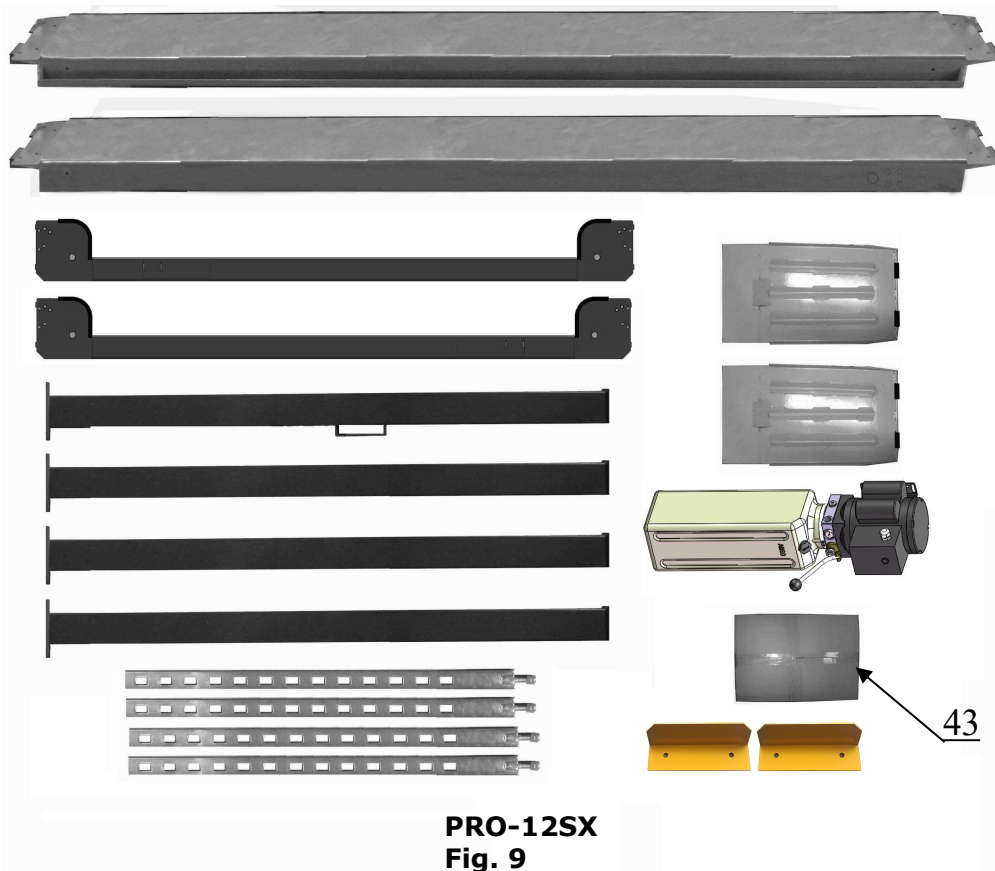

6. Open the carton of parts and check the parts according to the parts box list (See Fig. 11).



Fig. 11

7. Check the parts of the parts bag according to the parts bag list (See Fig. 12)

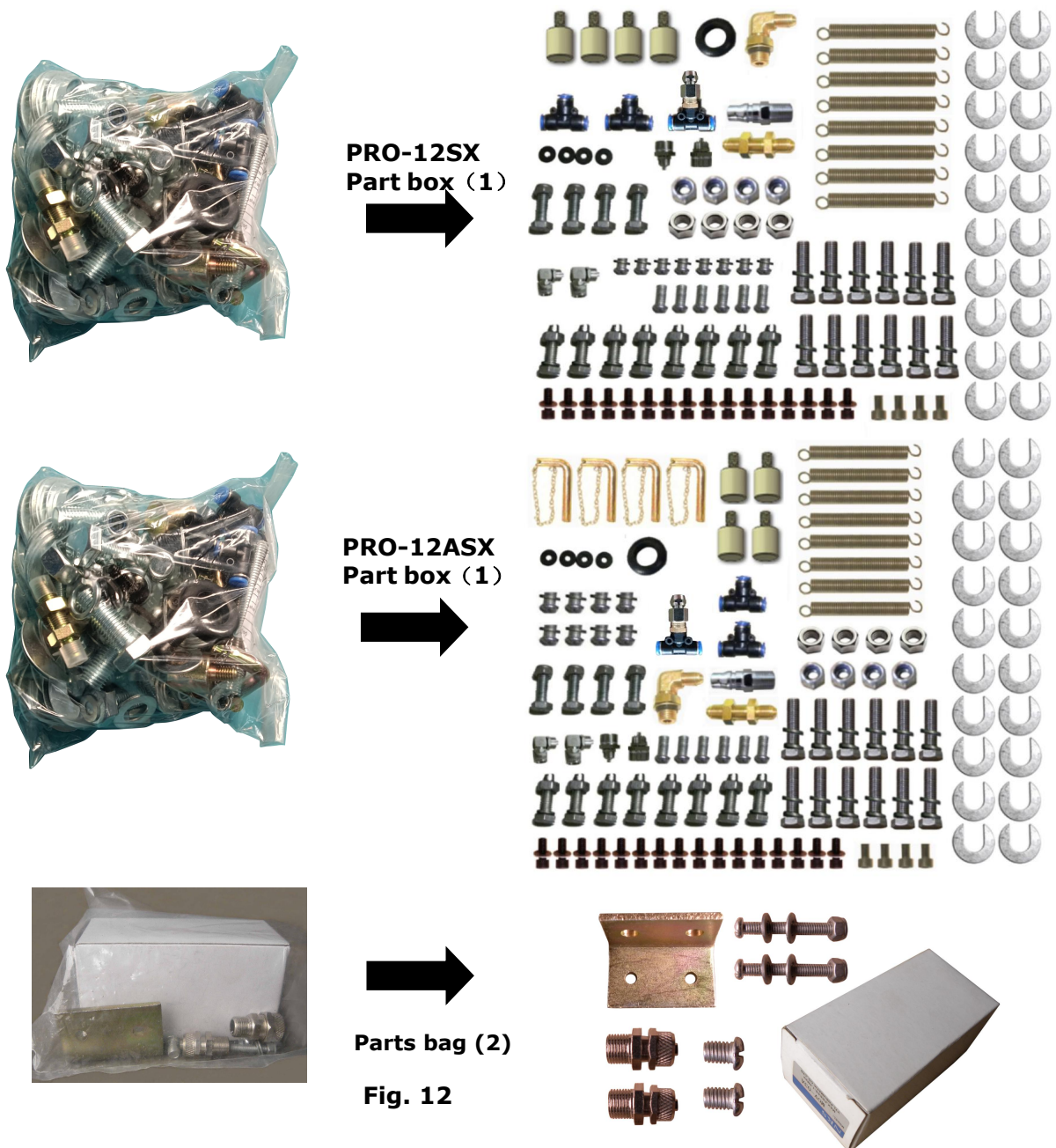

PRO-12SX
Part box (1)

PRO-12ASX
Part box (1)

Parts bag (2)

Fig. 12

C. Use a carpenter's chalk line to establish installation layout as per Table 1
 Make sure the size is right and base is flat (see Fig. 13).

Note: Reserve space front and behind the installation site.

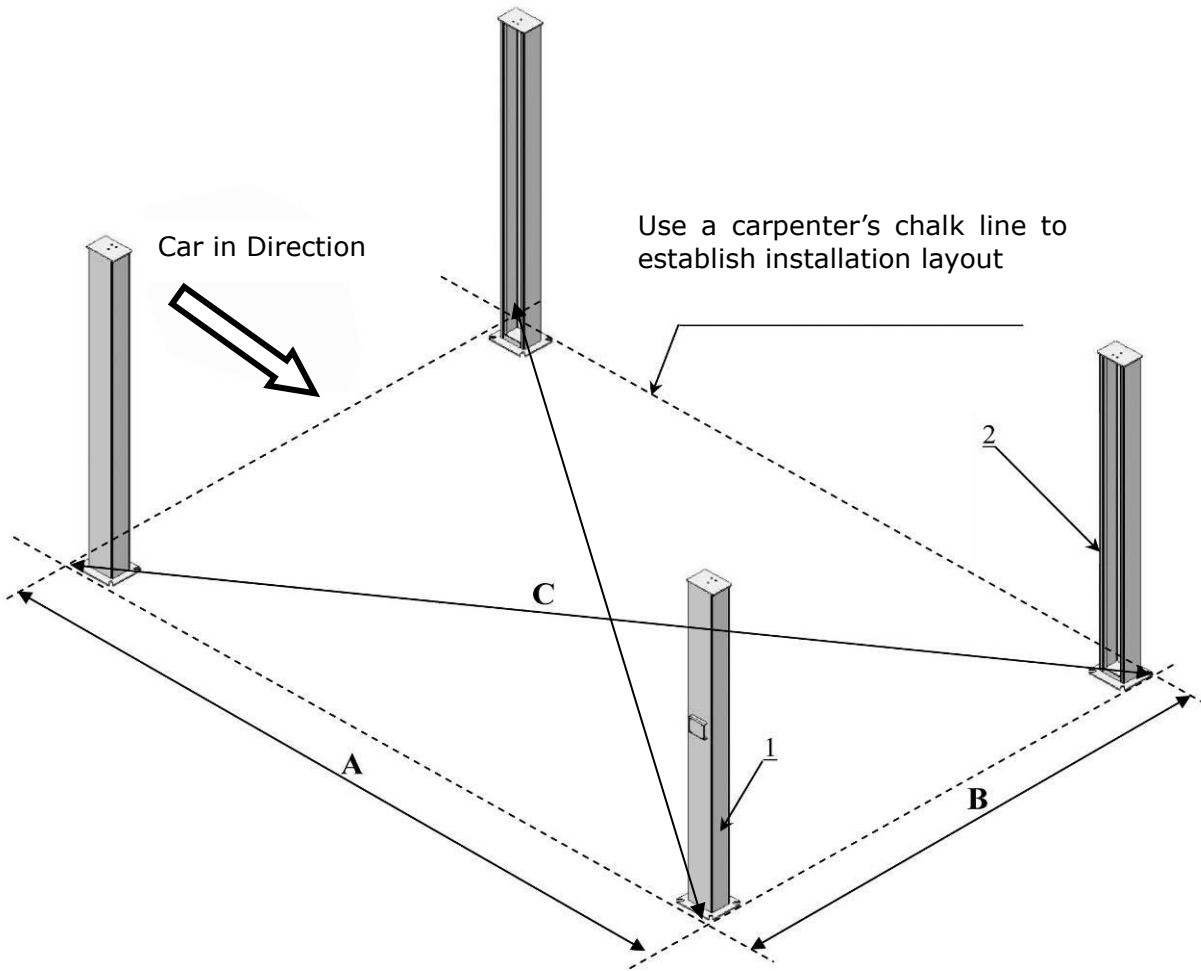
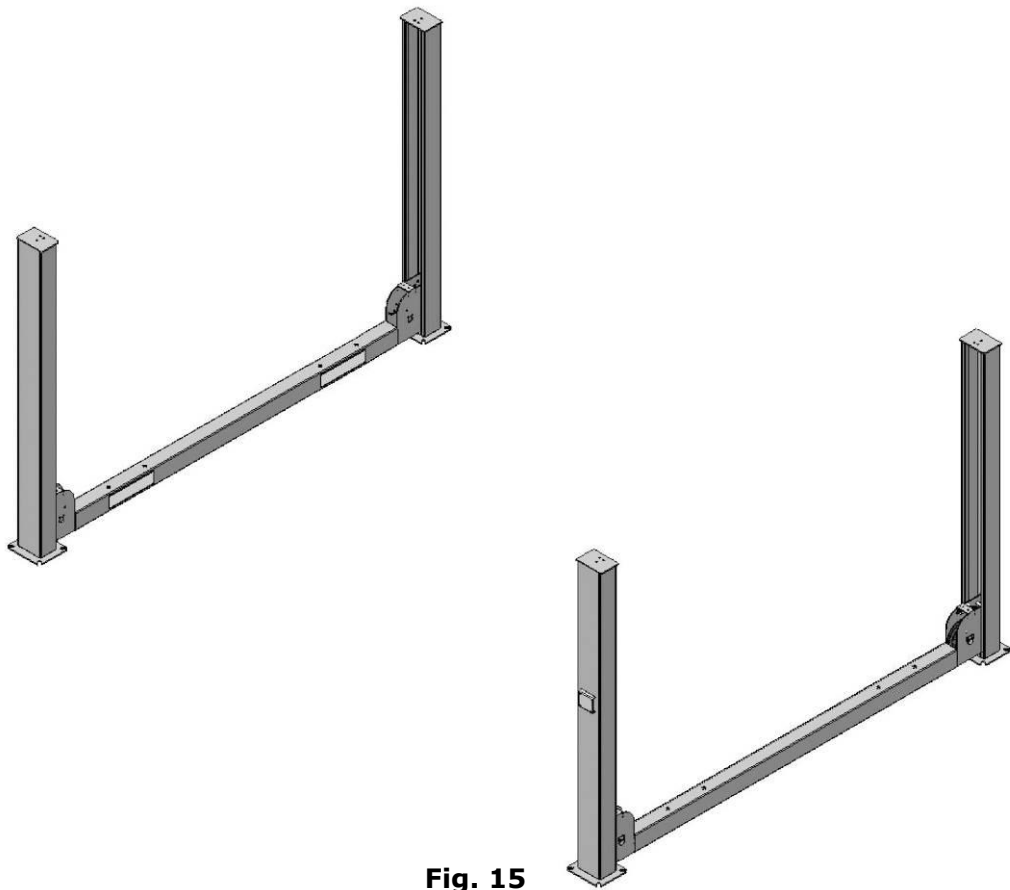
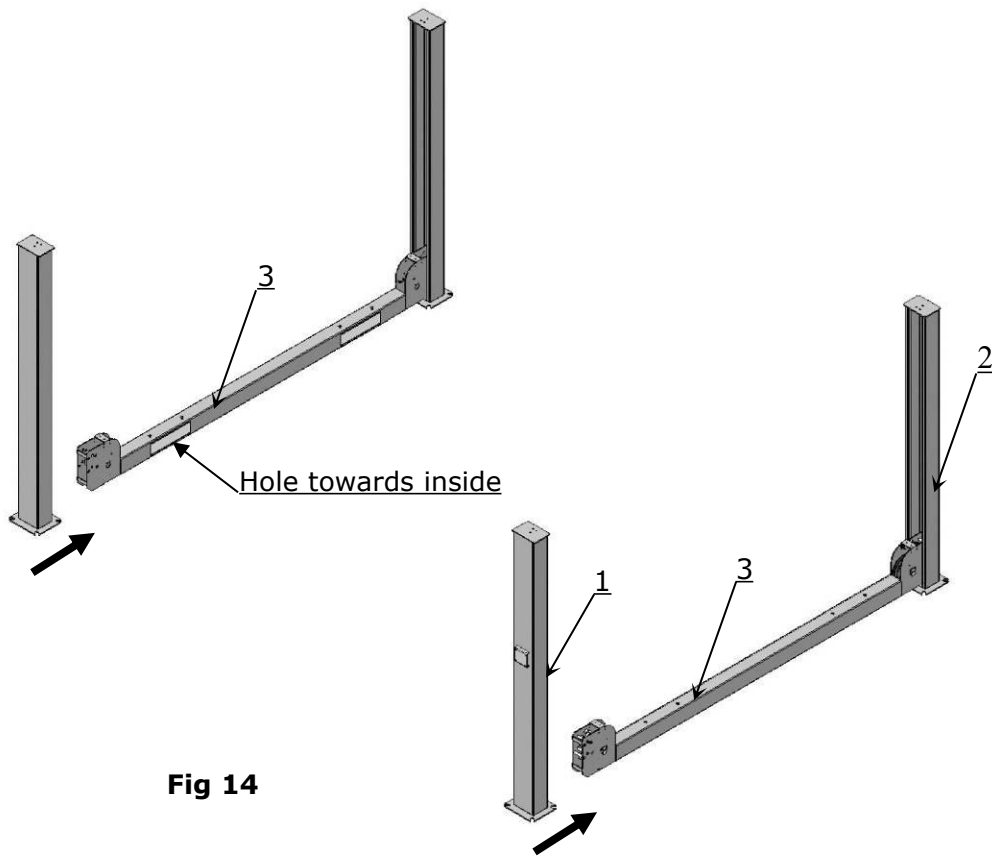

Fig. 13

MODEL	A	B	C	REMARK
PRO-12SX PRO-12ASX	196-3/4"	132-1/8"	237"	

D. Install cross beams (See Fig. 14, Fig. 15).



E. Fix the anchor bolts

1. Prepare the anchor bolts (See Fig. 16).

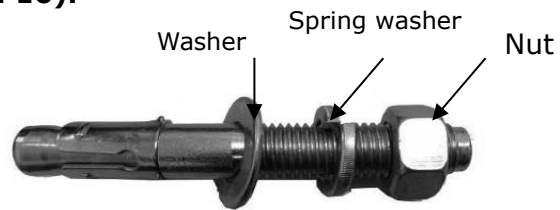

Fig. 16

2. Using the prescribed rotary hammer drill, and drill all the anchor holes and install the anchor bolts. Do not tighten the anchor bolts (See Fig. 17).

Note: Anchor bolts driven into the ground at least 90mm

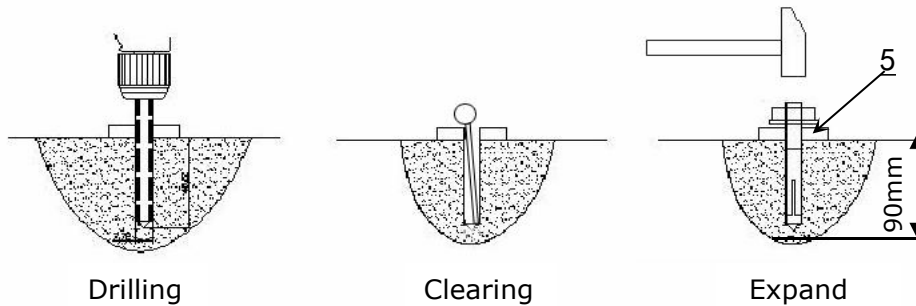

Fig. 17

F. Install the safety ladders

1. Take off the pulley safety cover and unscrew the four upper nuts of the Safety ladders, and then adjust the four lower nuts to be at the same position, then install the safety ladders (See Fig. 18).

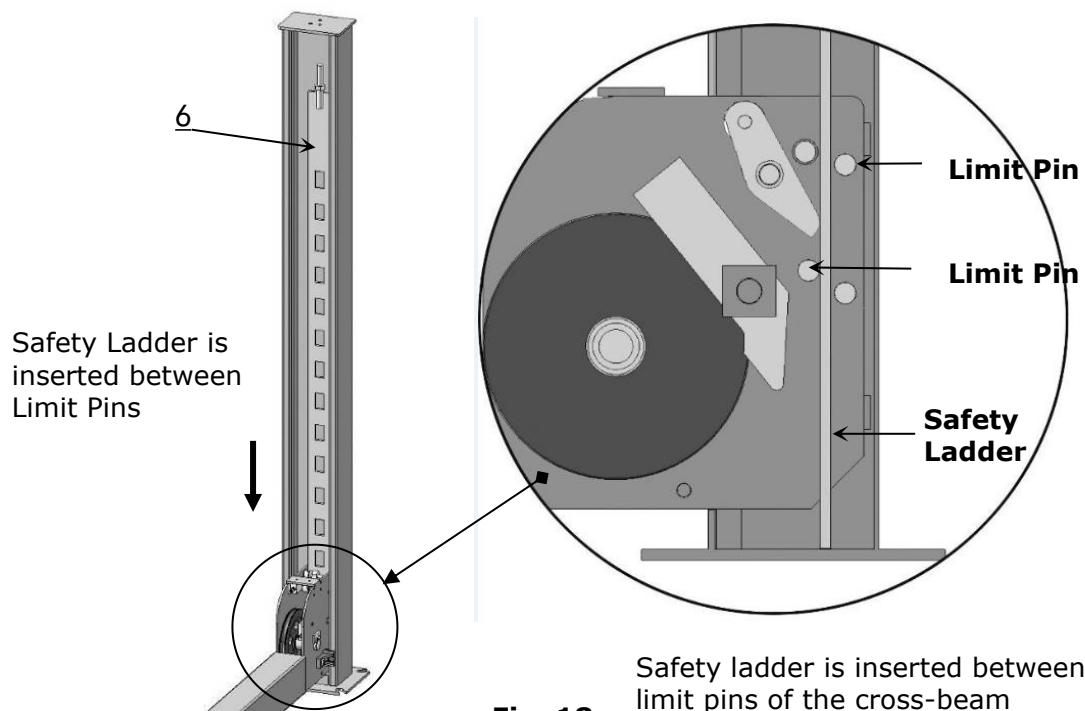

Fig. 18

2. Install safety ladders (See Fig. 19).

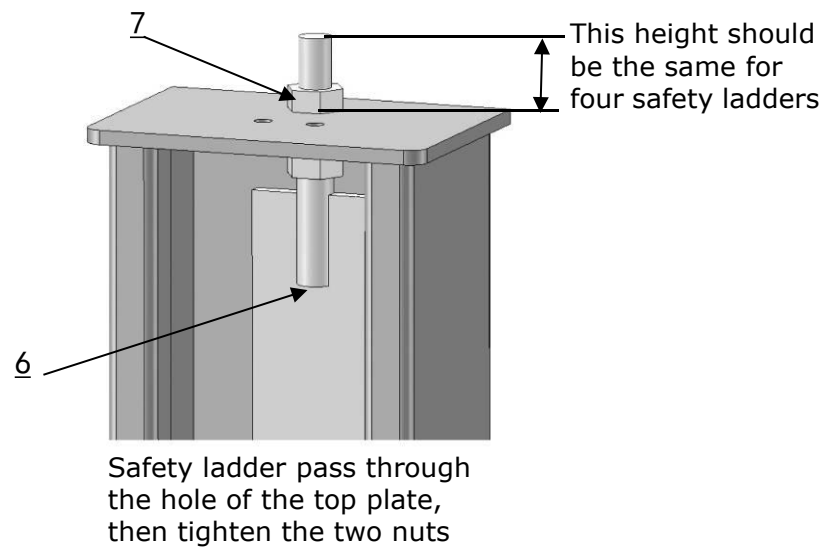

Fig. 19

G. Put the cross beams at the same height (See Fig. 20).

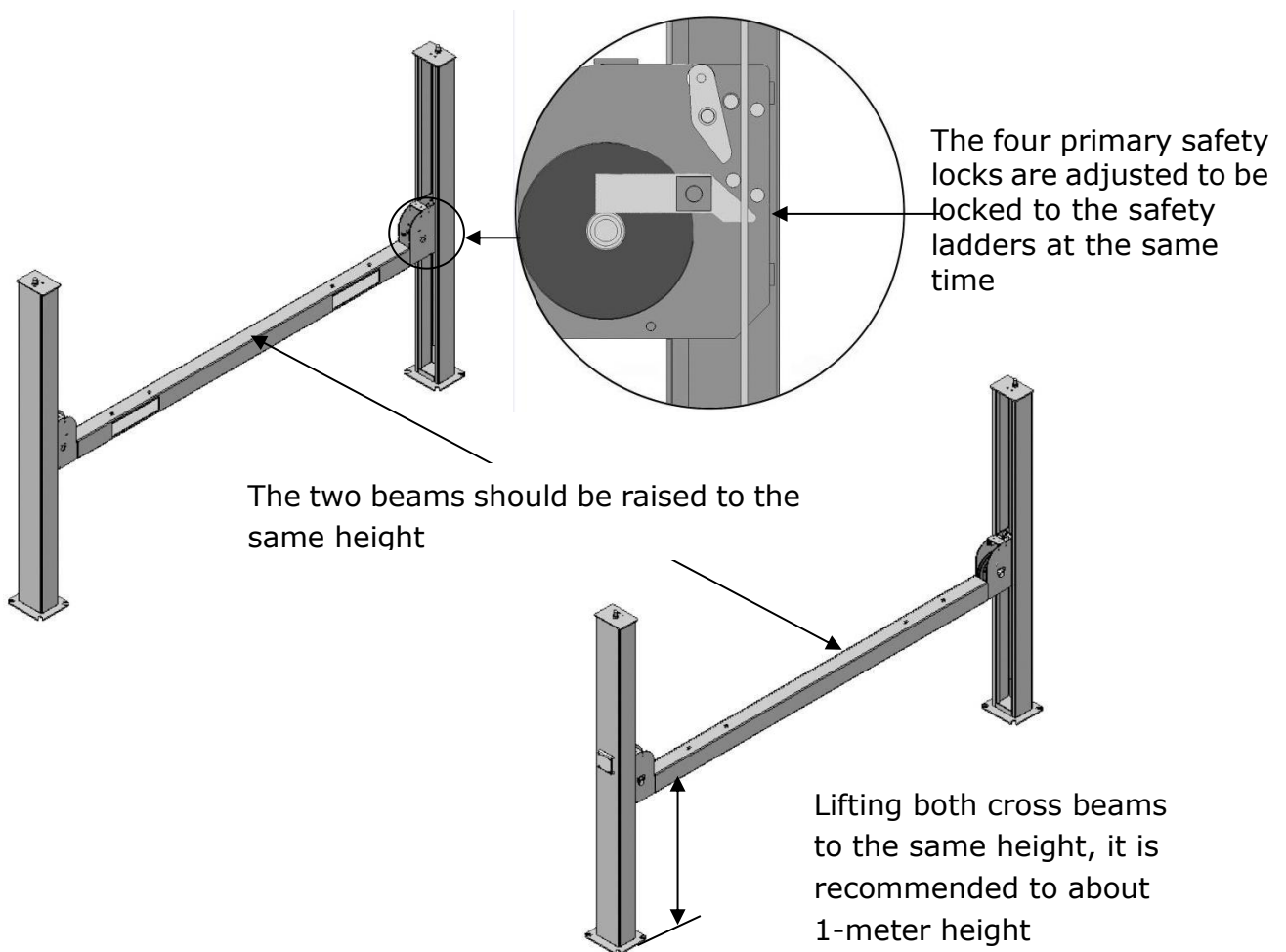
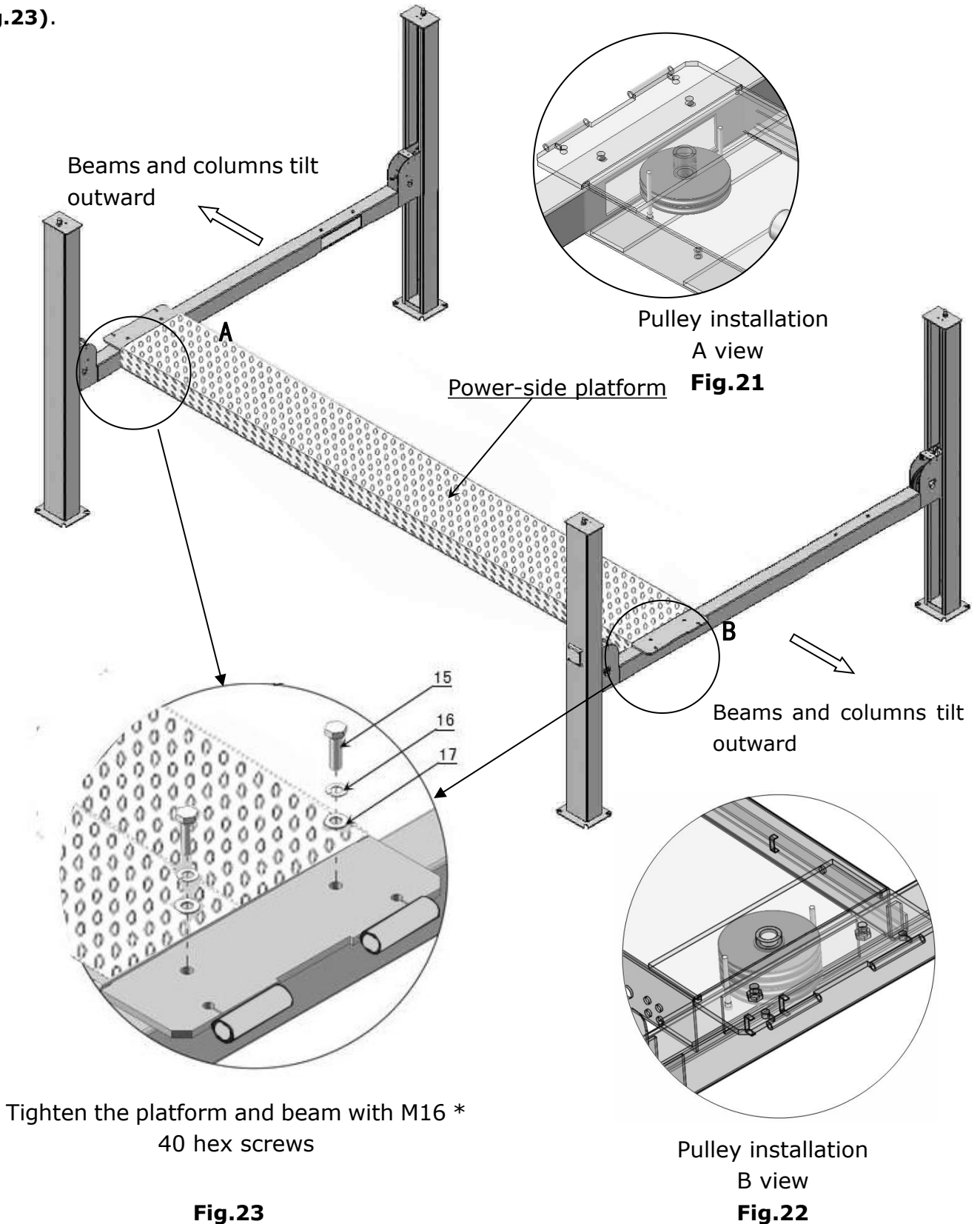

Fig. 20

H. Install power-side platform.

1. Put the power-side platform upon the cross beams by forklift or manual, offset the cross beams to the outside till the pulleys of both platforms can set up into the cross beam (See Fig.21,22), Install the power-side platform and screw up the bolts (See Fig.23).



I. Assembly offside platform and slider block, (See Fig. 24) check the plumbness of columns with level, adjusting with the shims if not, and then tighten the anchor bolts (See Fig. 25).

Measure the verticality of the four columns with a level to ensure that the columns are perpendicular to the ground. Shim can be used to adjust verticality.

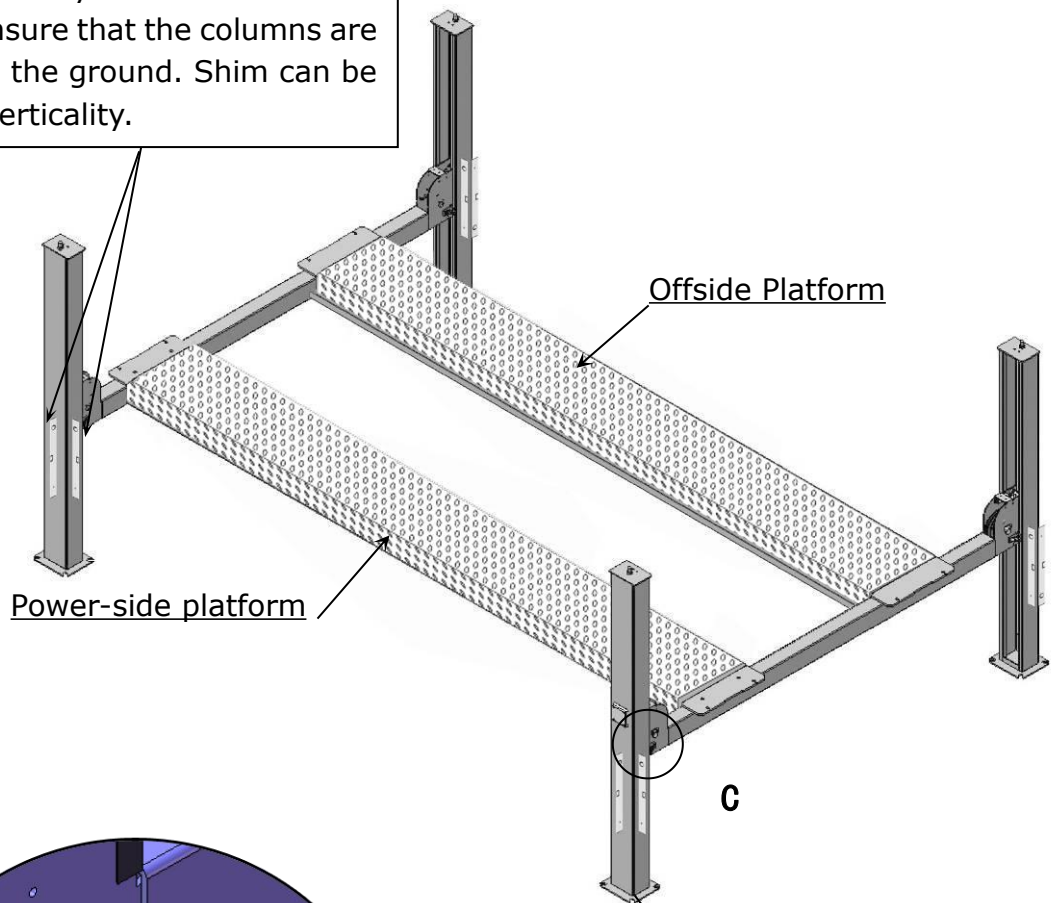

Note: Torque of Anchors is 150N.m.

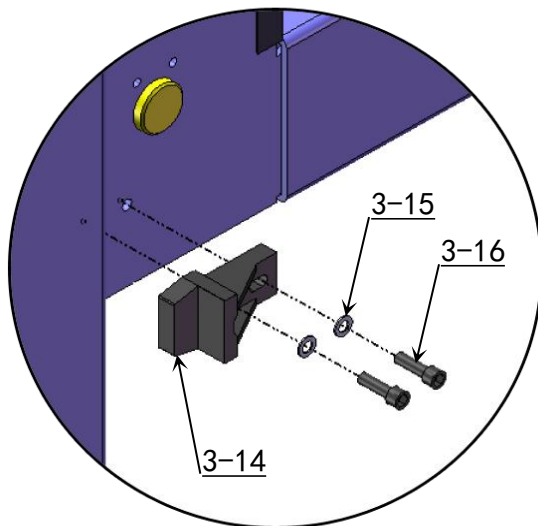

Install the slider block
C View
Fig. 24

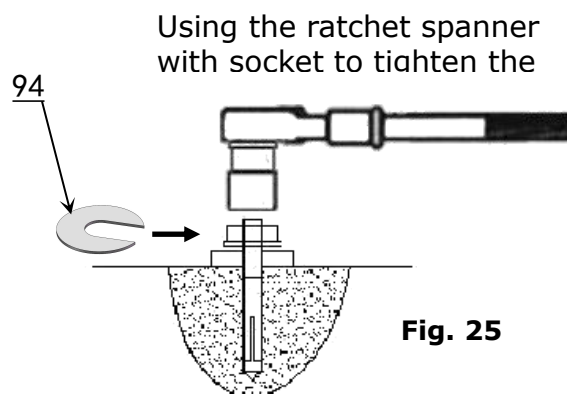

J. Illustration for cable installation (See Fig. 26).

1. Pass through the cables from the platform to the columns according to the number of the cables.

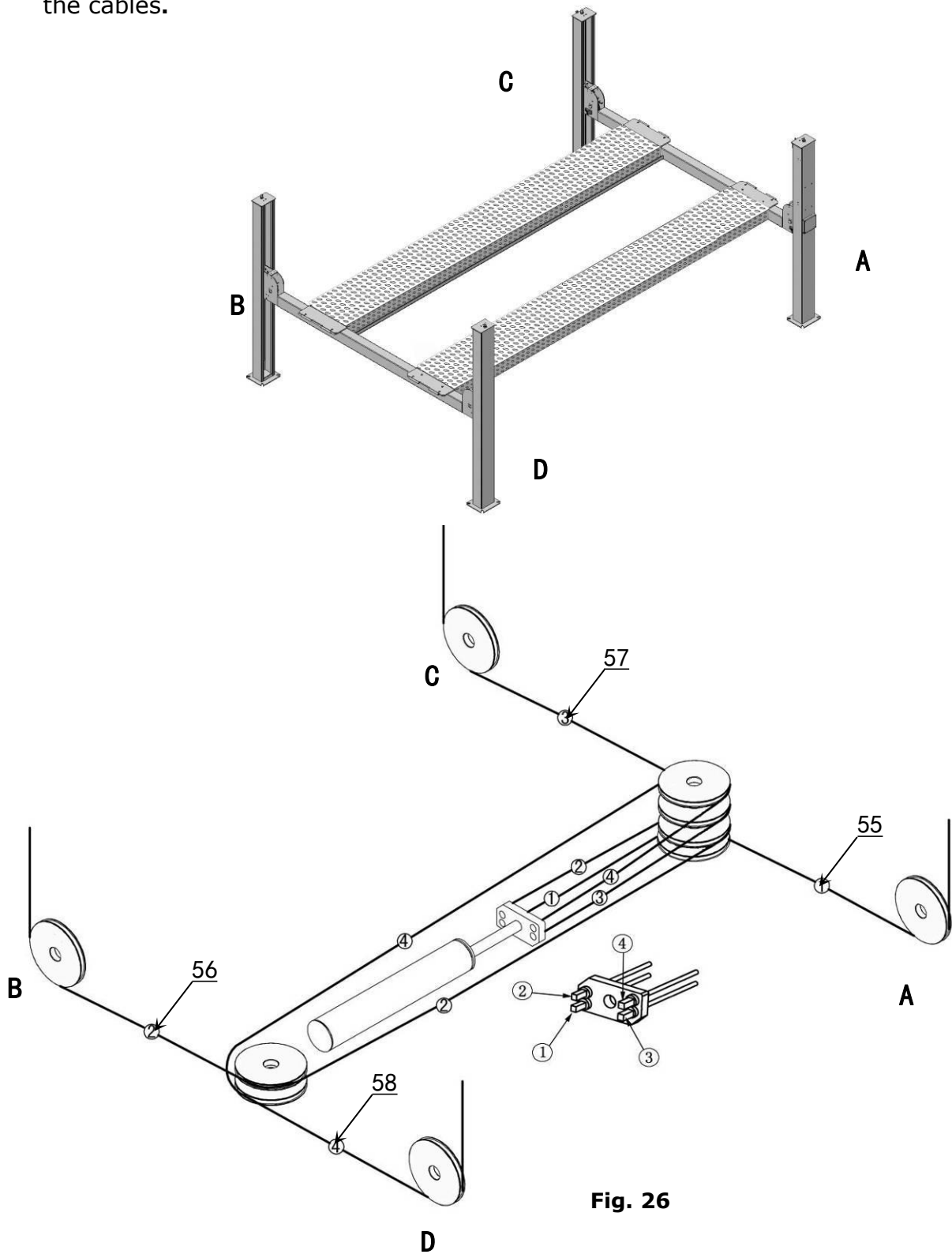
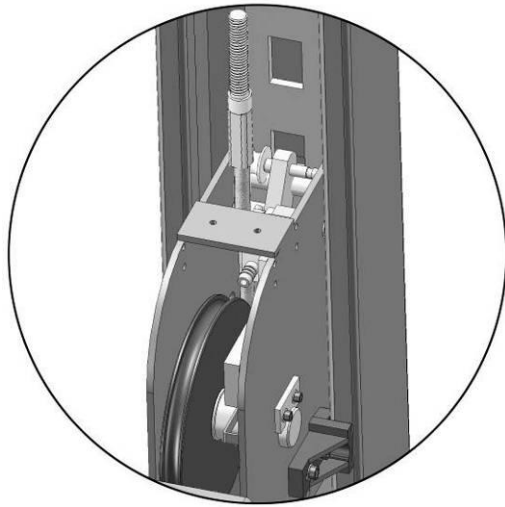

Fig. 26

Cable	No.	①	②	③	④
Length (w/ fitting)		146-5/8"	398-5/8"	209-5/8"	335-3/8"

2. The cable pass through the cross beam to top plate of columns and be screwed with cable nuts (See Fig. 27, 28), then install the cable limit pin. (See Fig. 29)



Cable pass through between the big pulley and tension pulley
D View
Fig.27

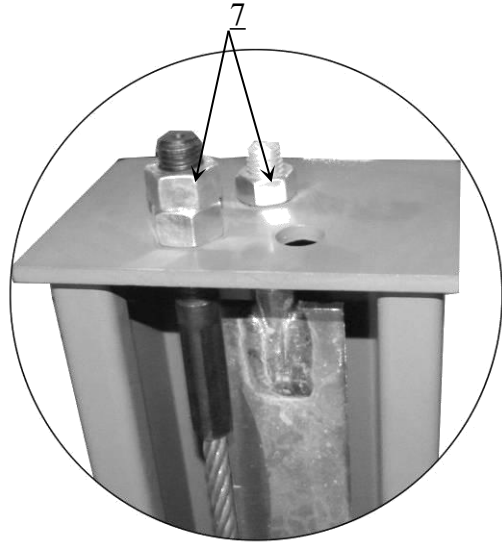

Cable pass through top plate and be screwed with cable nuts.

E View
Fig.28

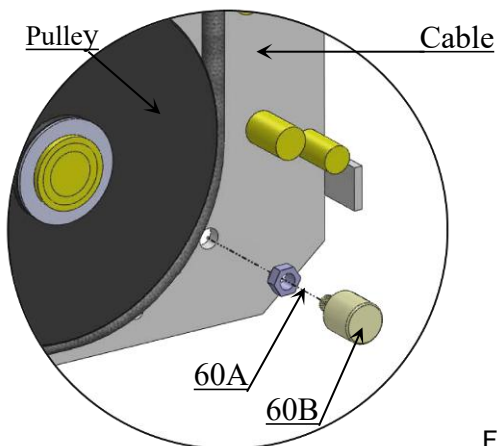
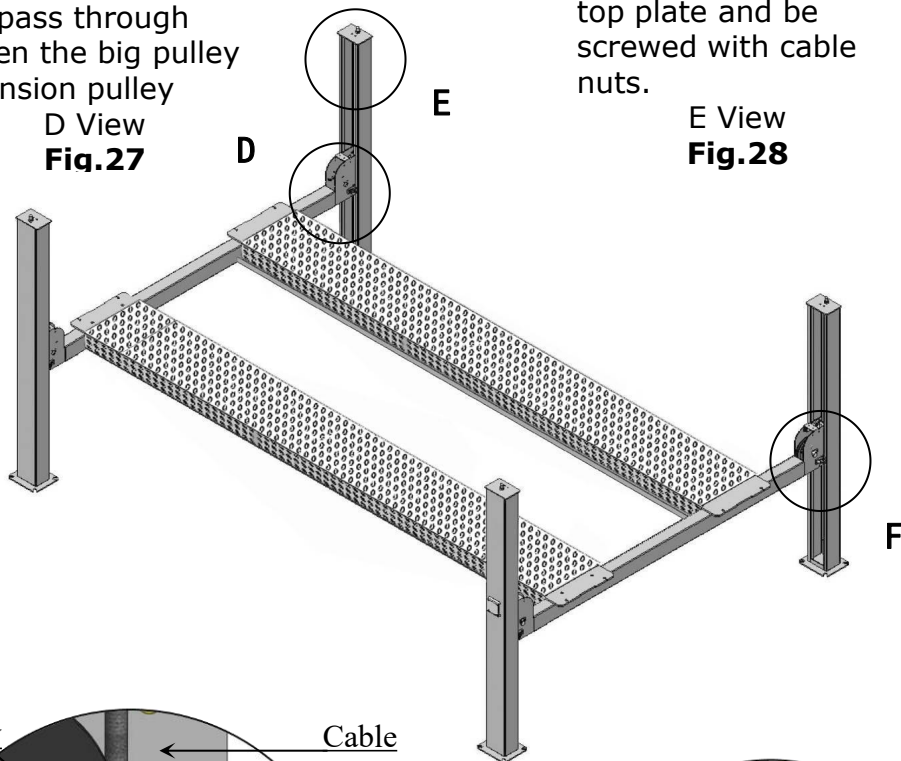

Install limit pin

F View
Fig. 29

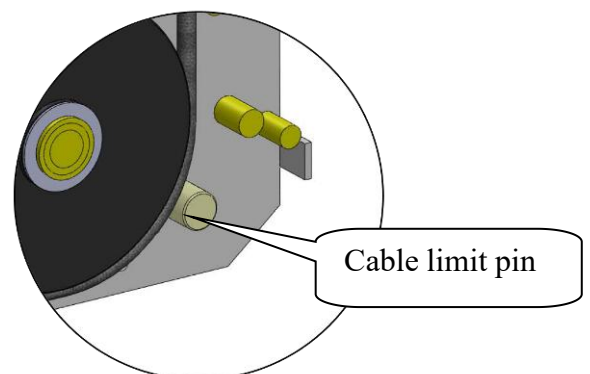

After installation

3. Illustration for platform cables (See Fig. 30, 31, 32).

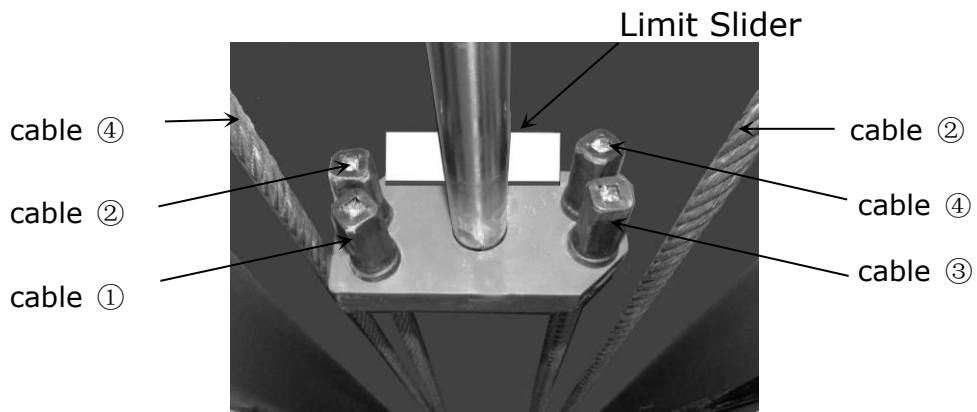

Fig. 30

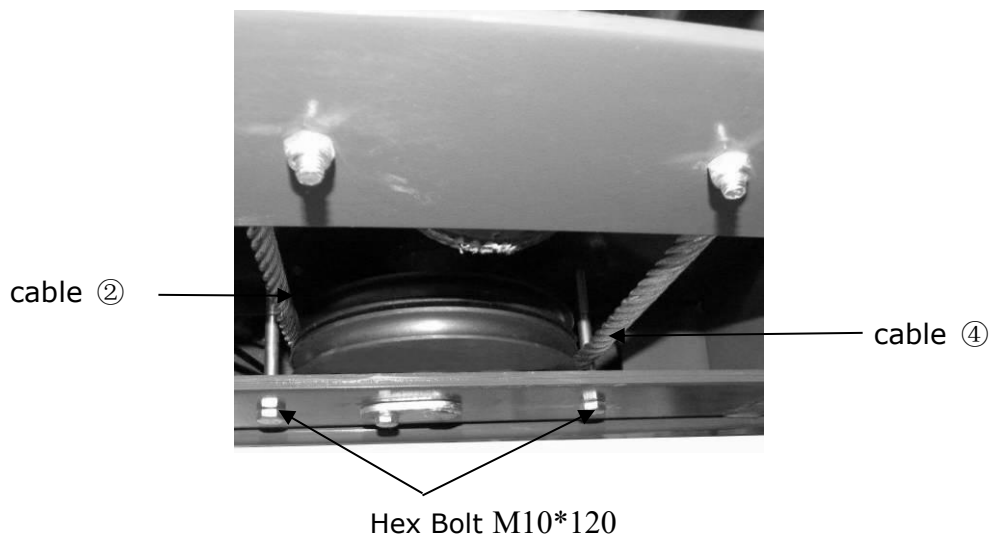
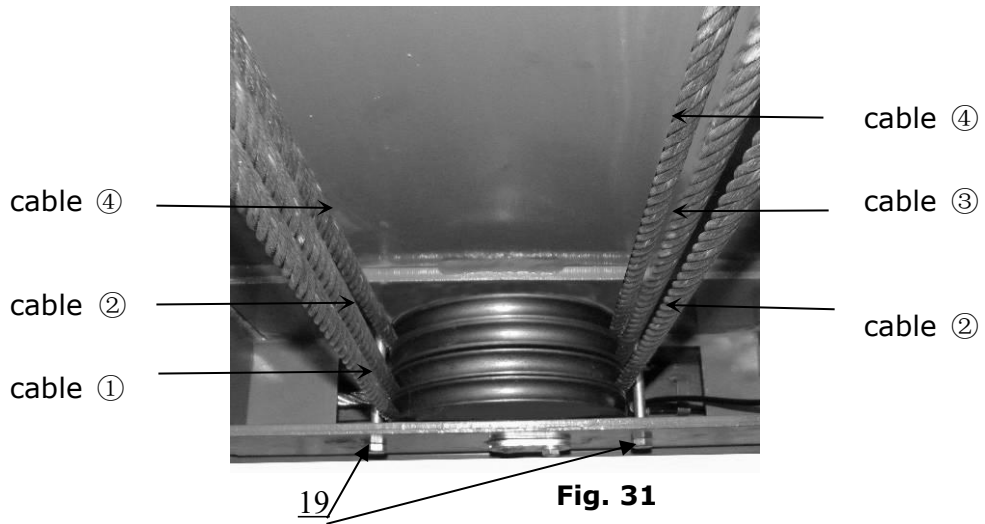

Fig. 32

K. Install oil-water separator, manual control air valve and power unit
(See Fig. 33).

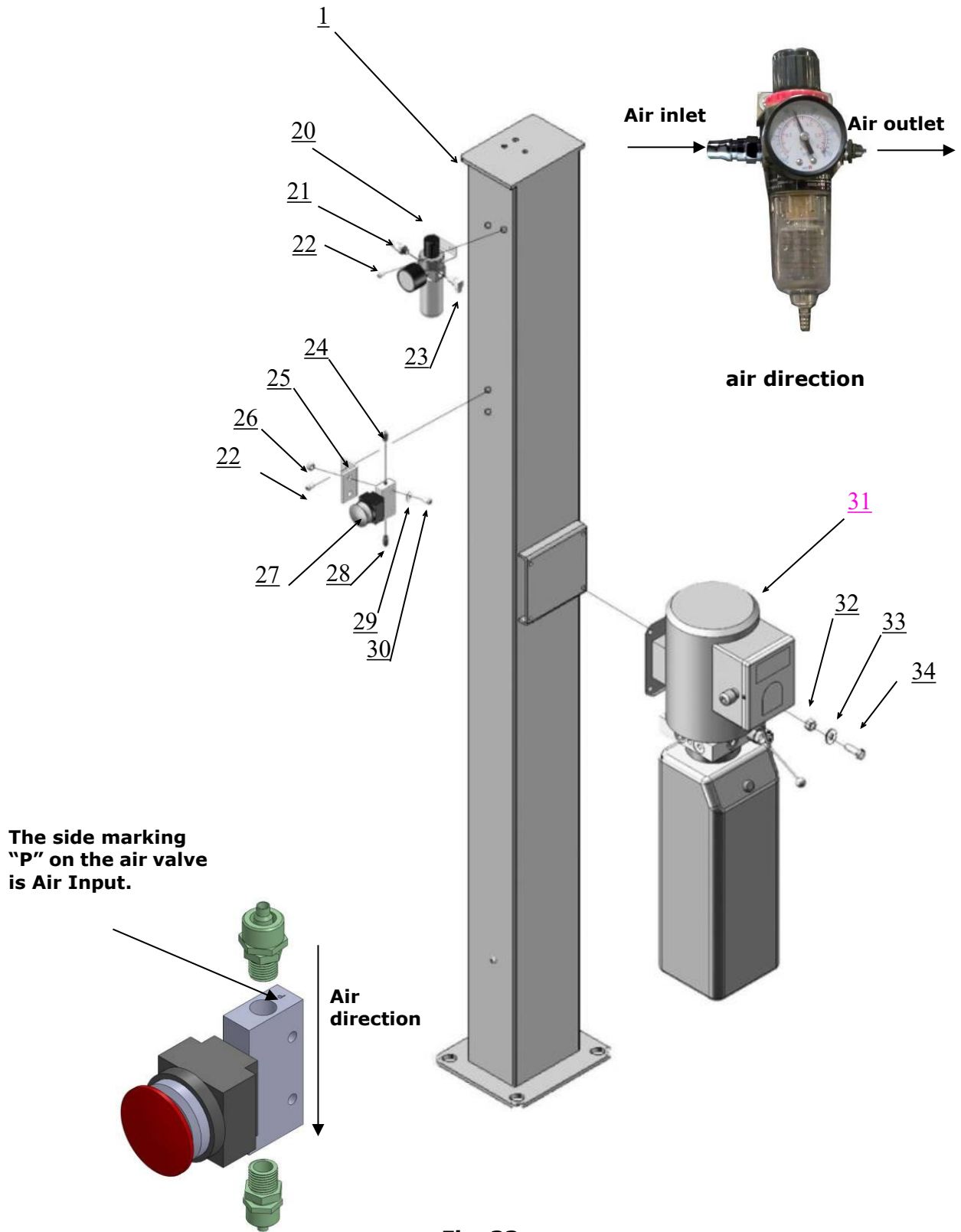
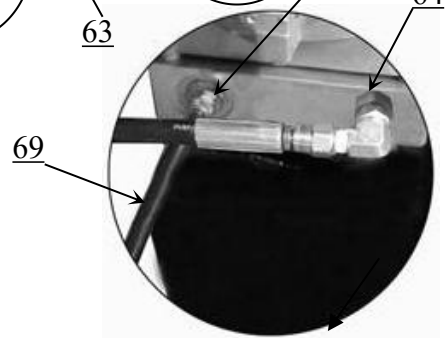
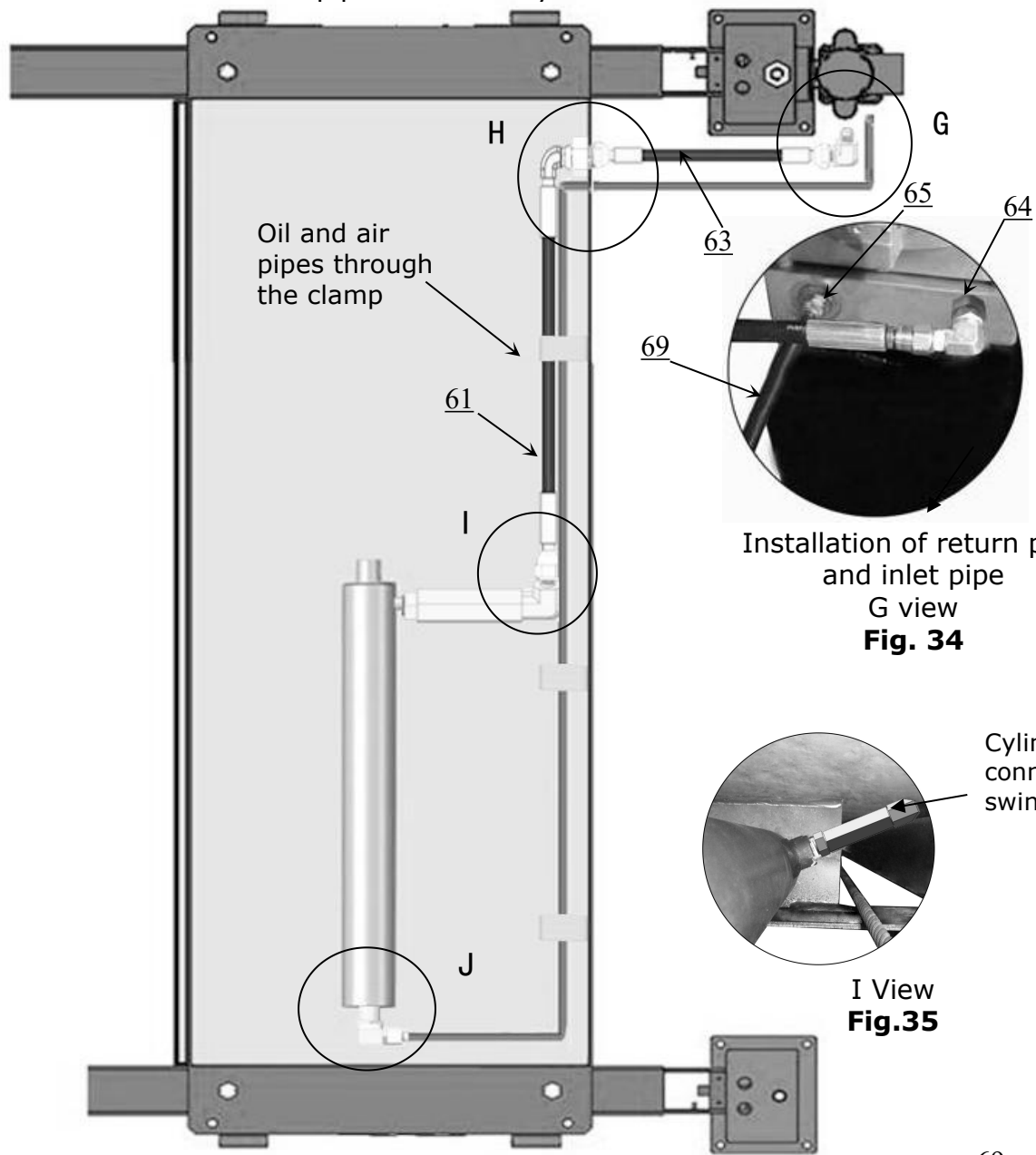

Fig. 33

L. Install hydraulic system.

Note: Oil hoses and oil return pipe connected to oil cylinder must be passed above the cable and cylinder inlet port must swing upward to avoid the oil hose and oil return pipe scratched by cable.



Installation of return pipe and inlet pipe
G view
Fig. 34

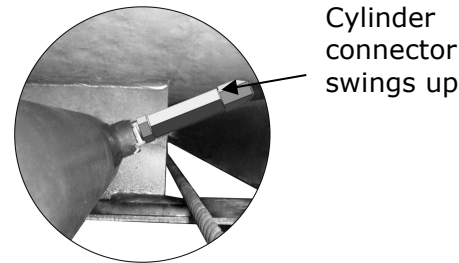

I View
Fig.35

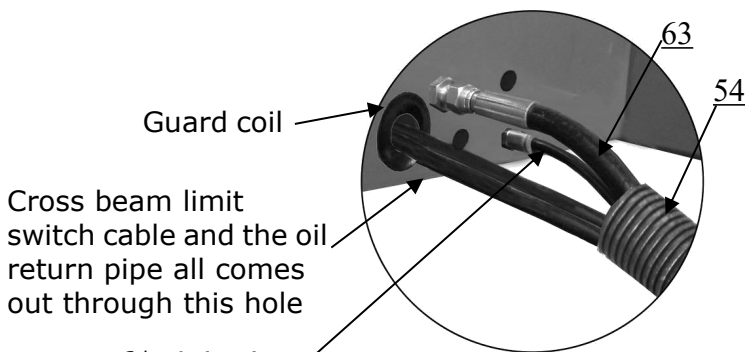

Need to be put into the bellows
H View
Fig.37

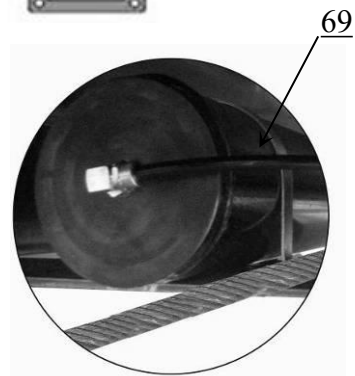

Oil return pipe installation
J View
Fig.36

M. Install air-line system

1. Connecting front and rear Cross Beam cylinders by using 6*4 black air pipe. (the actual length of air line can be cut by user) **(See Fig.38)**
2. Cut the 6*4 black air pipe by scissor between two retainers, then connect the air line with T fitting. **(See Fig. 39).**
3. Connecting the solenoid valve using 6*4 black air pipe (the actual length of air line can be cut by user) **(See Fig. 40).**

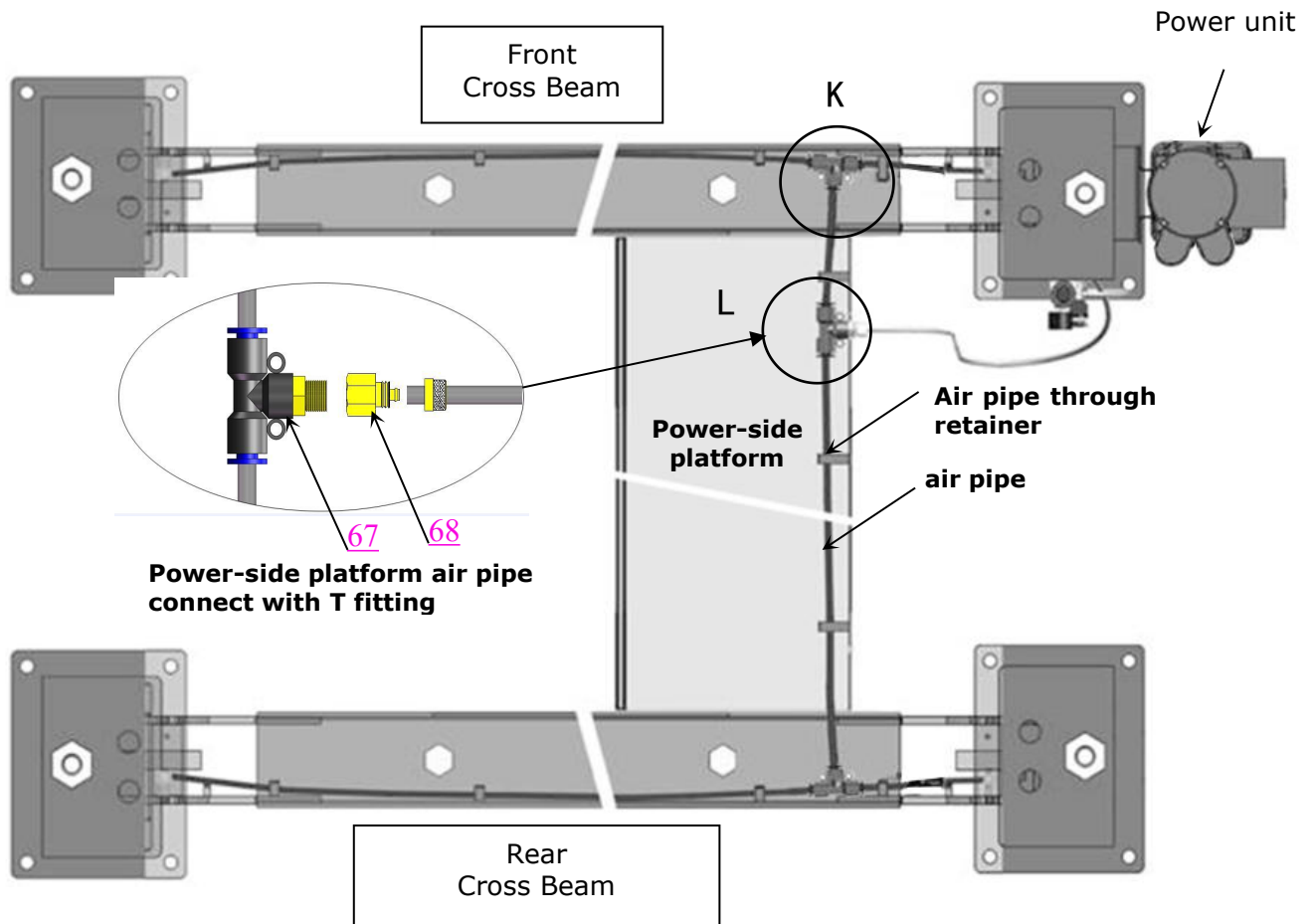
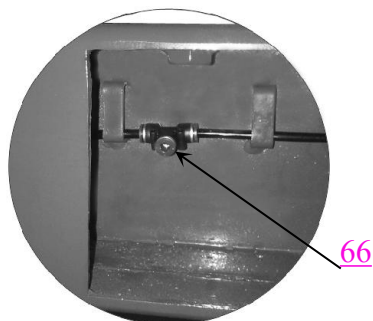
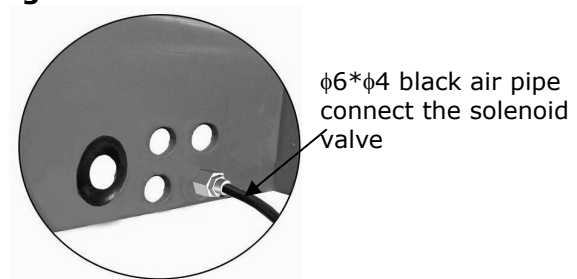

Fig.38



**K view
Fig.39**



**L view
Fig.40**

4. Connecting Oil-water separator and Manual control air valve using air line
(See Fig. 41).

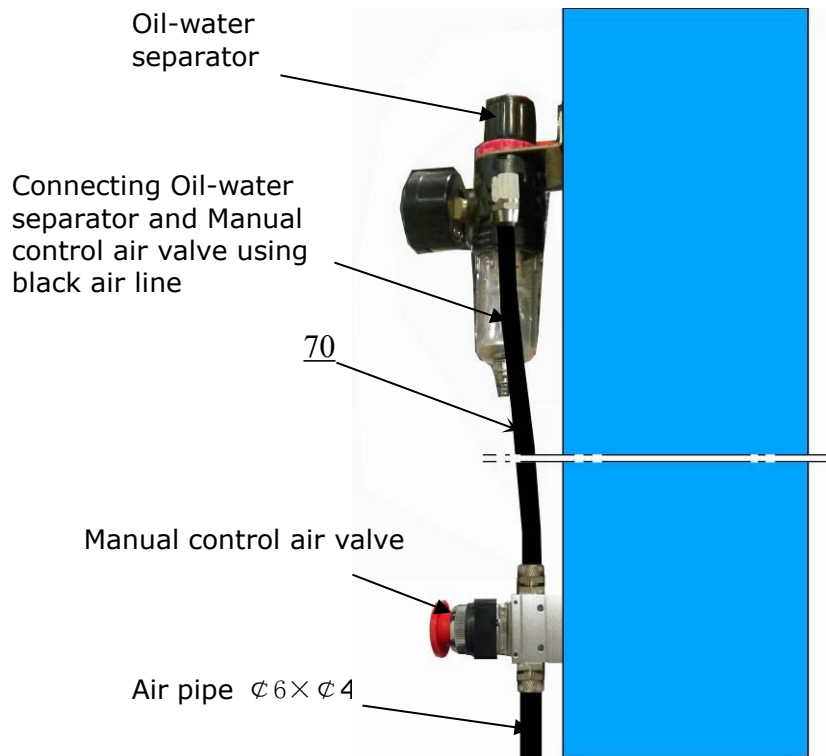

Fig. 41

5. Connecting air inlet (Air supply pressure 8 kg/cm²), adjusting the air pressure of Oil-water separator to 0.8 MPa (See Fig. 42).

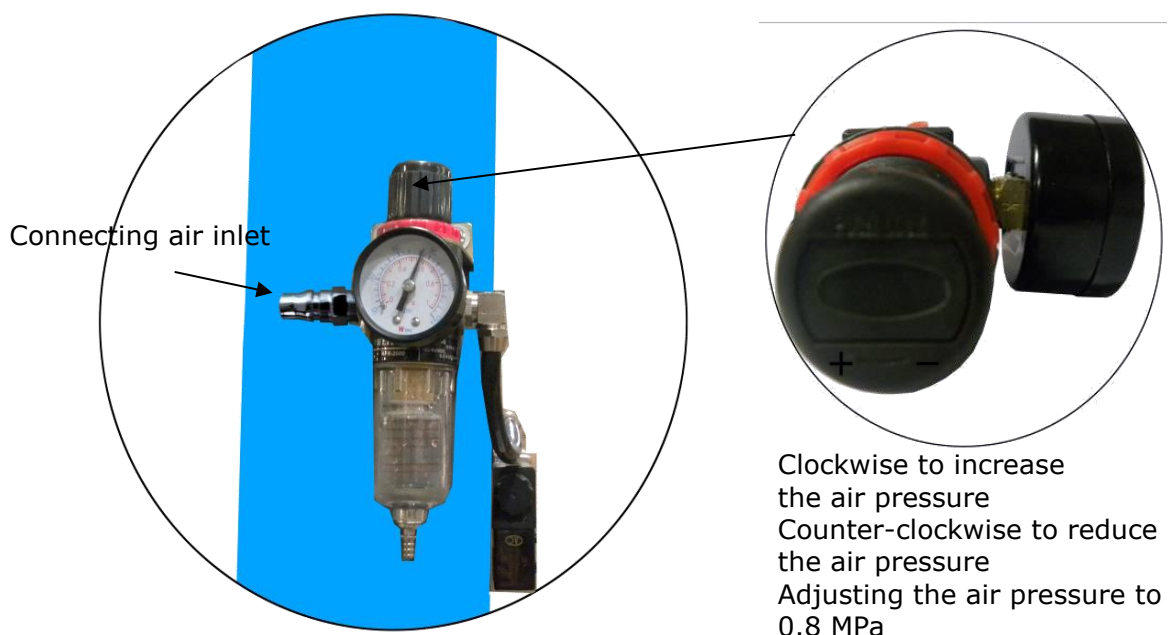

Fig. 42

O. Install Electrical System

Connect the power source on the data plate of Motor.

Note: For the safety of operators, the power wiring must contact the floor well.

Single phase motor (See Fig. 43)

Connecting the two power supply wires to terminals of AC contactor marked L1, L3 respectively.

Earth wire (yellow and green wire) is connected with the earth wire terminal of the motor.

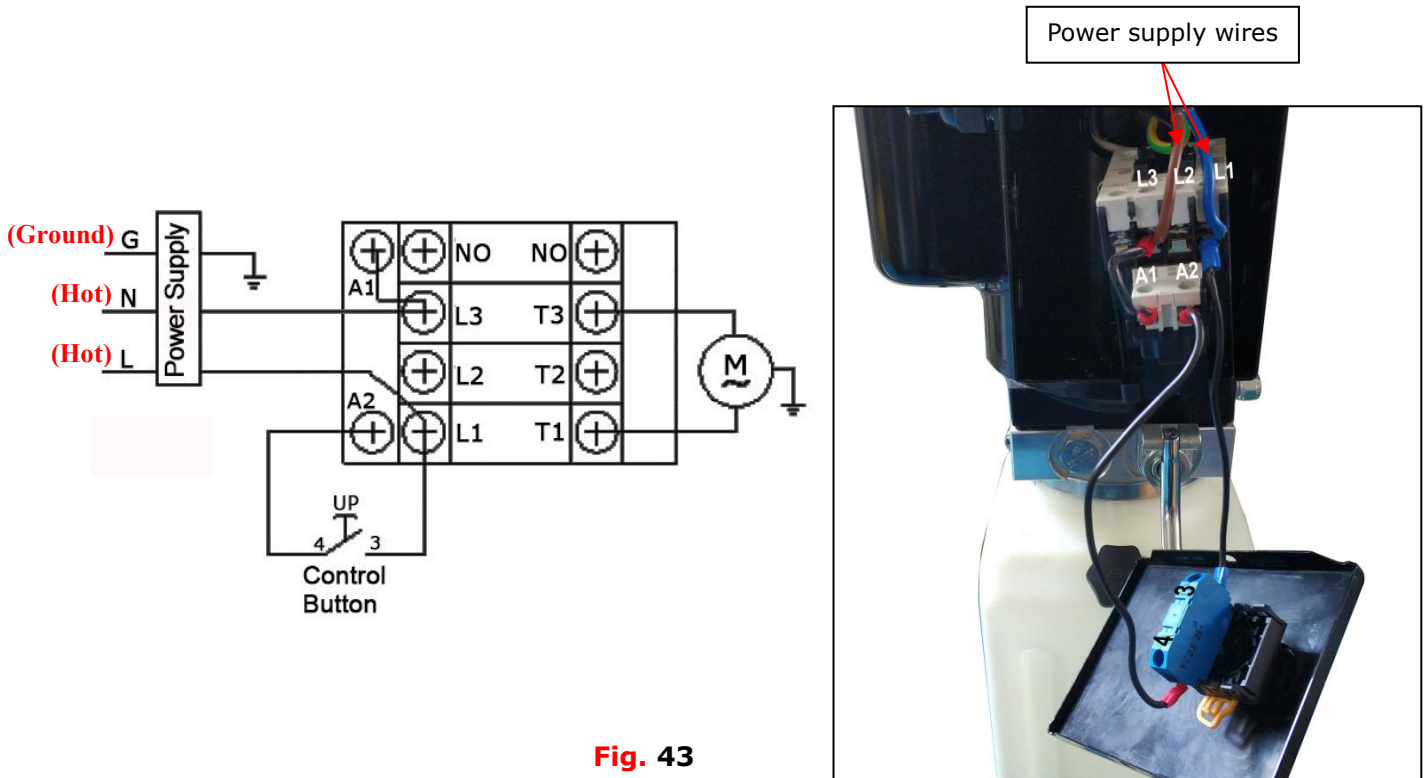

Fig. 43

O. Install spring and safety cover of cross beam (See Fig. 44)

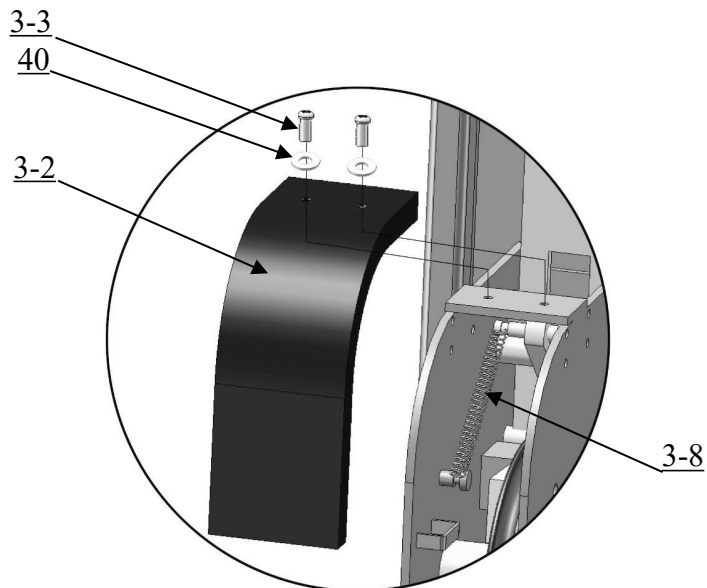
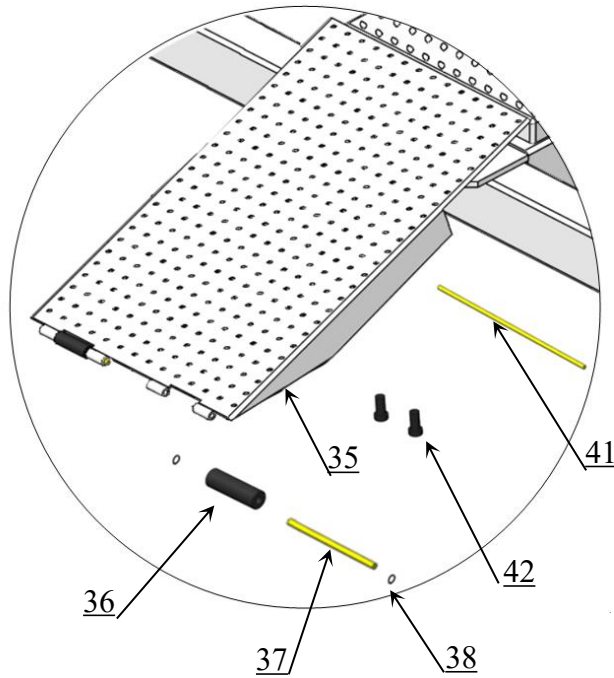

Fig. 44

P. Install drive-in ramp, tire stop plate, platform lock plates, Limit rod (See Fig. 45)

Install Drive-in ramp



Install Tire stop plate

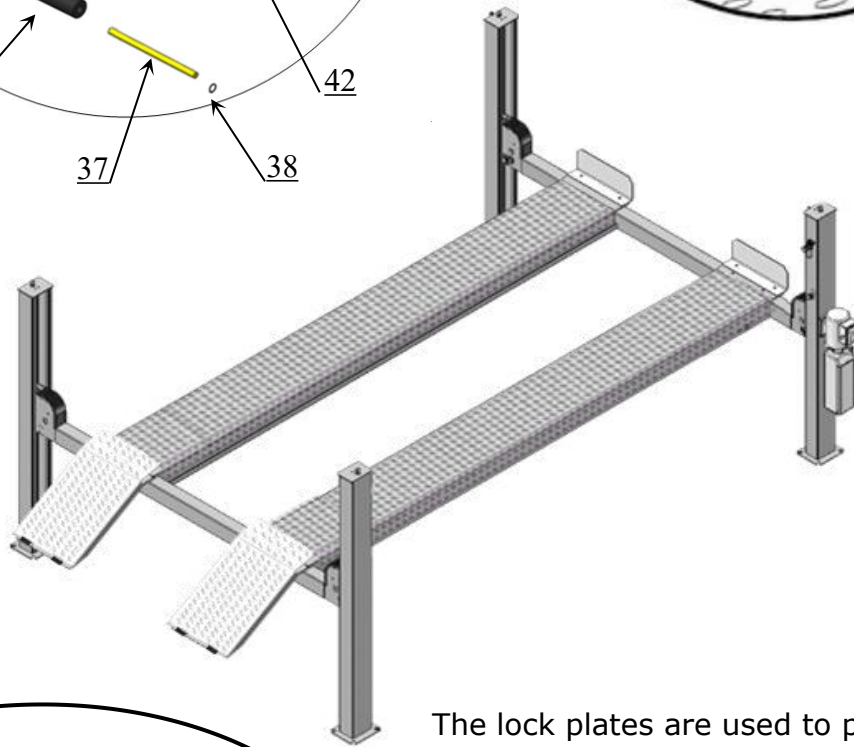
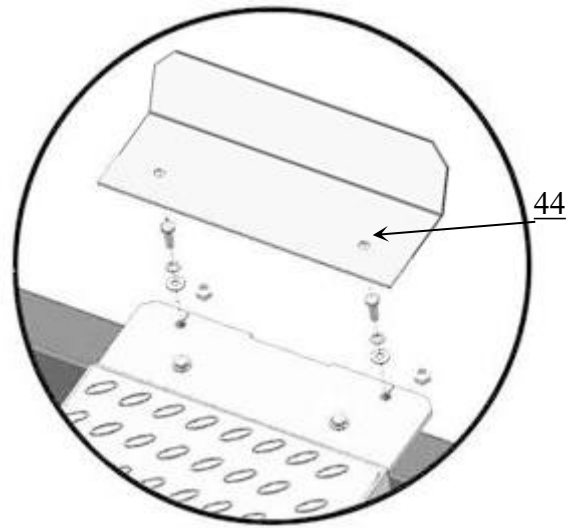

The lock plates are used to prevent the turning & slipping of offside platform, Using Hex bolt M8*20 for the connection.

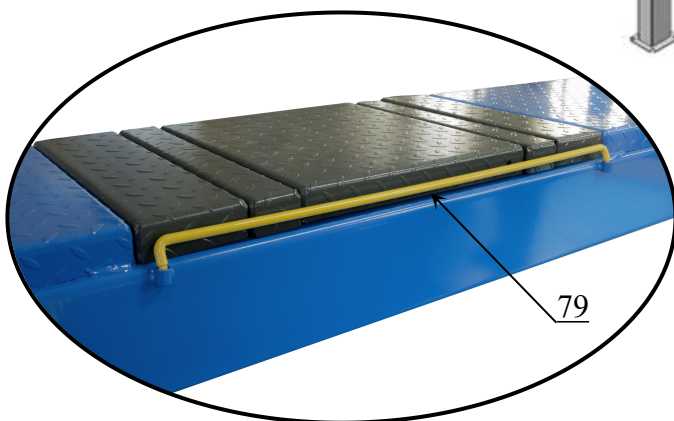

Install Limit rod

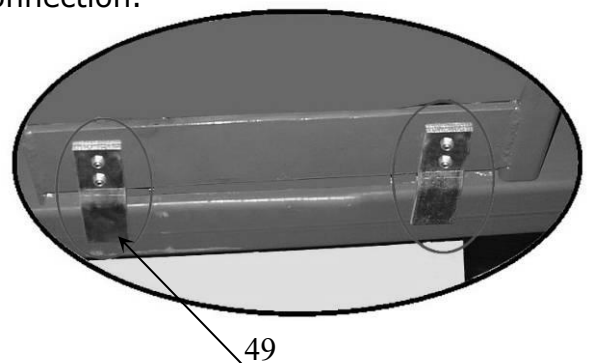

Fig.45

IV. EXPLODED VIEW

PRO-12SX

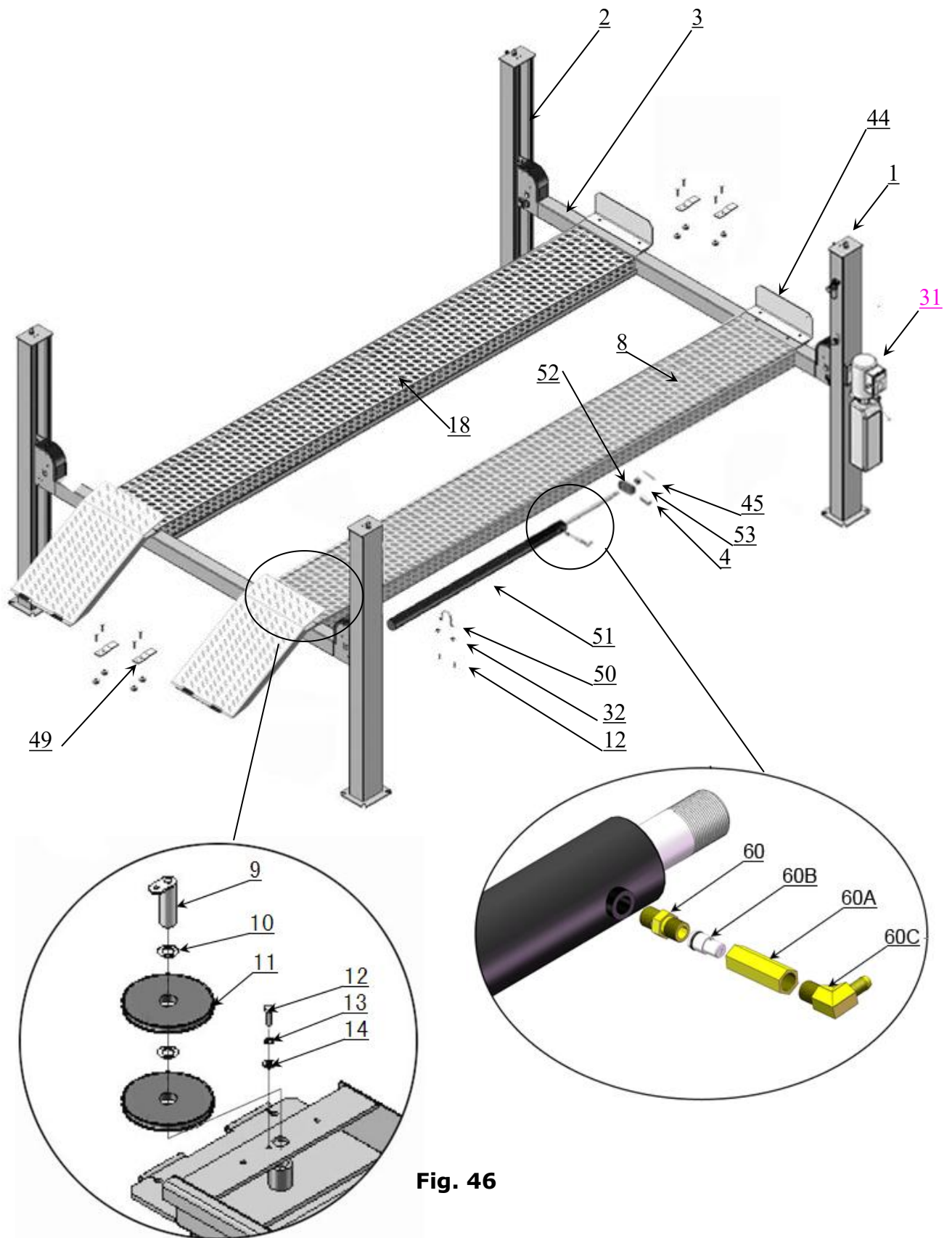

Fig. 46

PRO-12ASX

When installing the turntables, both sides are required a 35mm-high turntable block.

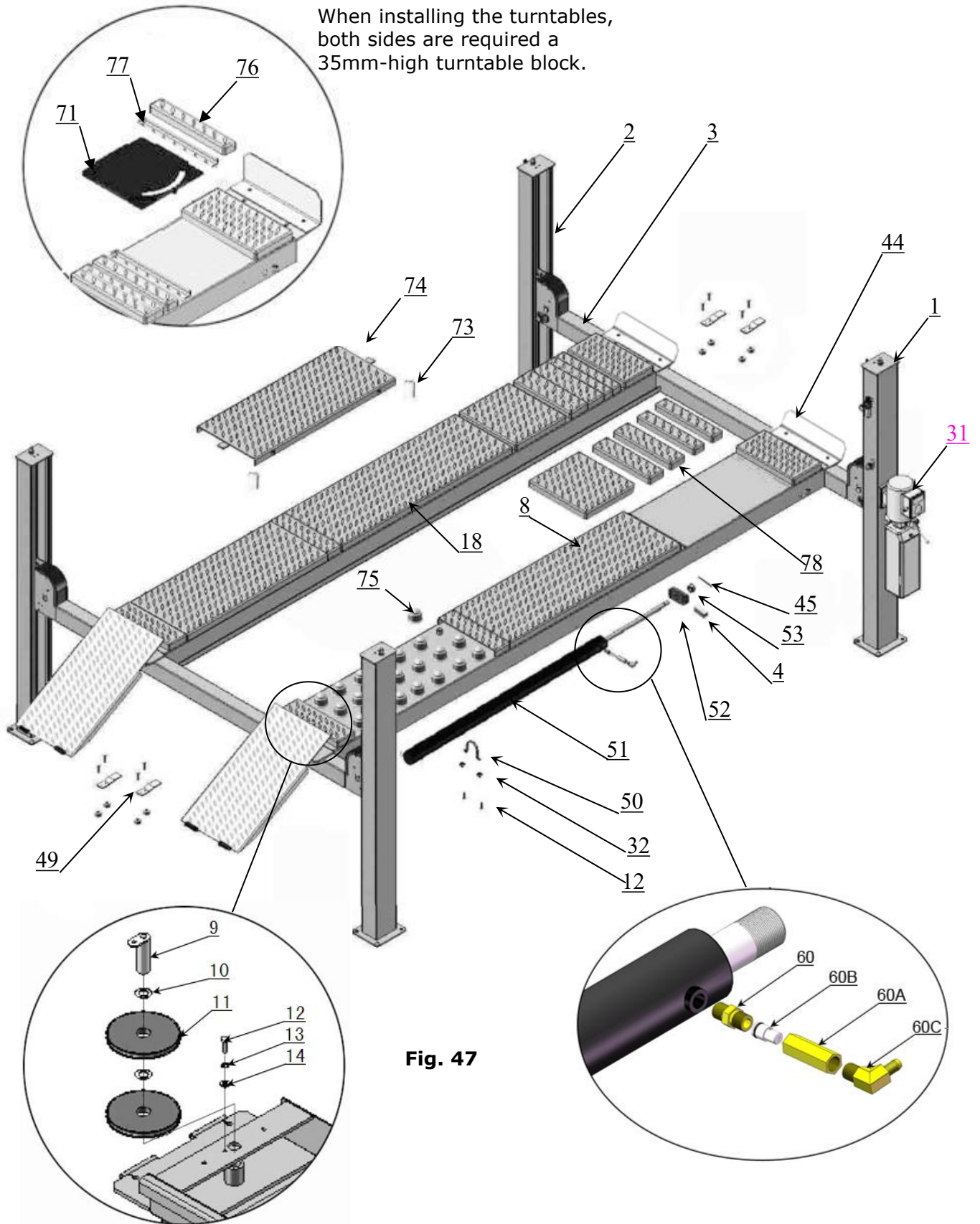

Fig. 47

PARTS LIST FOR PRO-12SX, PRO-12ASX

Item	Part#	Description	PRO-12S	PRO-12AS
1	11420011A	Power-side Column	1	1
2	11420002	Offside Column	3	3
3	10480040	Cross Beam Assy.	2	2
4	10420239	Slider block	1	1
5	10209059	Anchor Bolt 3/4*5-1/2	16	16
6	11410022	Safety Ladder	4	4
7	10420175A	Hex Nut M20	16	16
8	11490001	Power-side Platform	1	0
	11496001		0	1
9	11420022A	Pulley Shaft Weldment	2	2
10	10420023A	Washer $\phi 36*\phi 65*2.8$	12	12
11	11420024B	Pulley	10	10
11A	10420132A	Bronze Bush for Pulley	10	10
12	10209043	Hex Bolt M8*20	12	12
13	10209034	Lock Washer $\phi 8$	2	2
14	10420144	Washer $\phi 8*\phi 25*3$	2	2
15	10420030	Hex Bolt M16*40	12	12
16	10420137	Lock Washer $\phi 16$	12	12
17	10420029	Washer $\phi 16$	12	12
18	11490002	Offside Platform	1	0
	11496002		0	1
19	10420020B	Hex Bolt M10*120	4	4
20	10420145	Oil-water Separator AFR-2000	1	1
21	10420146	Straight Fitting for Air Line	1	1
22	10209009	Cap Head Bolt M6*8	4	4
23	10420076	90° Fitting for Air Line 6*8	1	1
24	10420159	Straight Fitting for Air Line	1	1
25	11420160	Fixing plate of Manual Control Valve	1	1
26	10420161	Self-locking Nut M4	2	2
27	10420162	Manual Control Air Valve	1	1
28	10420163	Straight Fitting for Air Line	1	1
29	10420148	Washer $\phi 4$	4	4
30	10420164	Cap Head Bolt M4*30	2	2
31	071101	Manual Power Unit	1	1
32	10209005	Self-locking Nut	14	14
33	10209004	Rubber Ring $\phi 8*20*3$	4	4
34	10209003	Hex Bolt M8*25	4	4
35	11420003	Drive-in Ramp assy.	2	0
	11430002		0	2
36	11610667	Drive-in Ramp pulley	4	4
37	11620043	Drive-in Ramp pulley pin	4	4
38	10209010	Snap ring $\phi 10$	8	8
39	10420156	Protecting Ring	1	1

Item	Part#	Description	PRO-12S	PRO-12AS
40	10420045	Washer φ6	20	20
41	11420004	Pin for Drive-in Ramp	2	2
42	10420005	Fixing Bolt M5*8	4	4
43	10420502	Part box	1	0
	10430501	Part box	0	1
44	11420031-1	Tire stop plate	2	2
45	10201005	Split pin φ4*50	1	1
46	10620065	Shim 2mm	20	20
	10201090	Shim 1mm	20	20
47	10209056	Self-locking Nut M10	4	4
48	11420217	Cable limit pin	4	4
49	11420007	Fixing plate against rollover	4	4
50	11410090	Cylinder fixing ring	1	1
51	10410081	Cylinder	1	1
52	11420626	Cable connecting plate	1	1
53	10420014	Hex nut M27	1	1
54	10420016B	Protective hose φ40*2*1500mm	1	1
55	10490005	No.① Cable L=3725mm	1	1
56	10490006	No.② Cable L=10125mm	1	1
57	10490004	No.③ Cable L=5325mm	1	1
58	10490003	No.④ Cable L=5325mm	1	1
59	10420166	90° Fitting 6*4	1	1
60	11420243	Straight Fitting for Cylinder	1	1
60A	10420245	Fitting	1	1
60B	10209119	Balancing valve	1	1
60C	10201020	90° Fitting	1	1
61	10490007	Oil Hose (straight+90°)	1	1
62	10420120	Extended Straight Fitting (with Nut)	1	1
63	10207026	Oil Hose L=1520mm (double straight)	1	1
64	10209060	90° Fitting	1	1
65	10420095	Straight Fitting for Power Unit	1	1
66	10420124	T Fitting	2	2
67	10420242	T fitting	1	1
68	10420241	Straight Fitting	1	1
69	10420195	Oil Return Hose φ6*φ4*5700mm black	1	1
69A	10420131C	Black Air Line φ6*φ4	1	1
70	10420167A	Black Air Line φ8*φ6*460mm	1	1
71	1040101	Turnplate	0	2
72	11430004	Cover for Turnplate	0	2
73	11520037	Pin	0	4
74	11480028	Side slide plate	0	2
75	10420157	Alignment ball set	0	54
76	11480033	Turnplate block 483*76*50	0	4
77	11480045	Turnplate block 483*35*35	0	4
78	11480082	Turnplate block 483*141*50	0	4
79	11440090	Limit rod	0	4

4.1 CROSS BEAM (10480040)

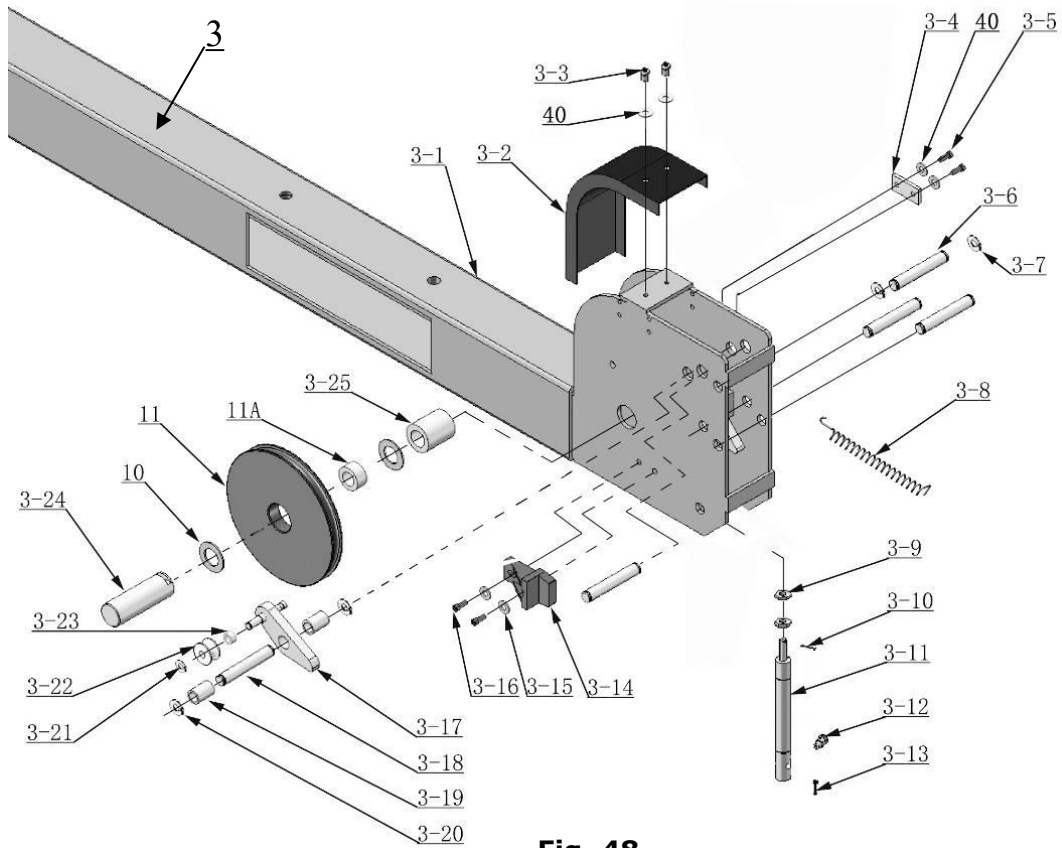

Fig. 48

Item	Part#	Description	Qty	Note
3-1	11480023	Cross Beam	2	
3-2	10420051B	Pulley Safety Cover	4	
3-3	10209009	Cap Head Bolt M6*8	8	
3-4	11420044	Limit Plate	4	
3-5	10420138	Socket Bolt M6*16	8	
3-6	11420038	Pin φ16	12	
3-7	10420037	Snap Ring φ16	24	
3-8	10420033	Spring	4	
3-9	10209021	Hex Nut M10	8	
3-10	10420049	Split Pin φ2*16	4	
3-11	10420048	Air Cylinder	4	
3-12	10420047	Fitting for Air Cylinder	4	
3-13	10420046	Split Pin φ4*30	8	
3-14	10420042	Slider block	8	
3-15	10209033	Washer φ8	24	
3-16	10420043	Socket Bolt M8*20	16	
3-17	11420175	Slack-cable safety lock (left & right)	2	
	11420240		2	
3-18	11420171	Pin φ19	8	
3-19	11420172	Pin Bush for Slack-cable safety lock	8	
3-20	10206019	Snap Ring φ19	16	
3-21	10209010	Snap Ring φ10	4	
3-22	10420035	Tension Pulley	4	
3-23	11420174	Spacer	4	
3-24	11420041A	Pulley Pin	4	
3-25	11420040A	Pulley Bush	4	

4.2 CYLINDERS (10410081)

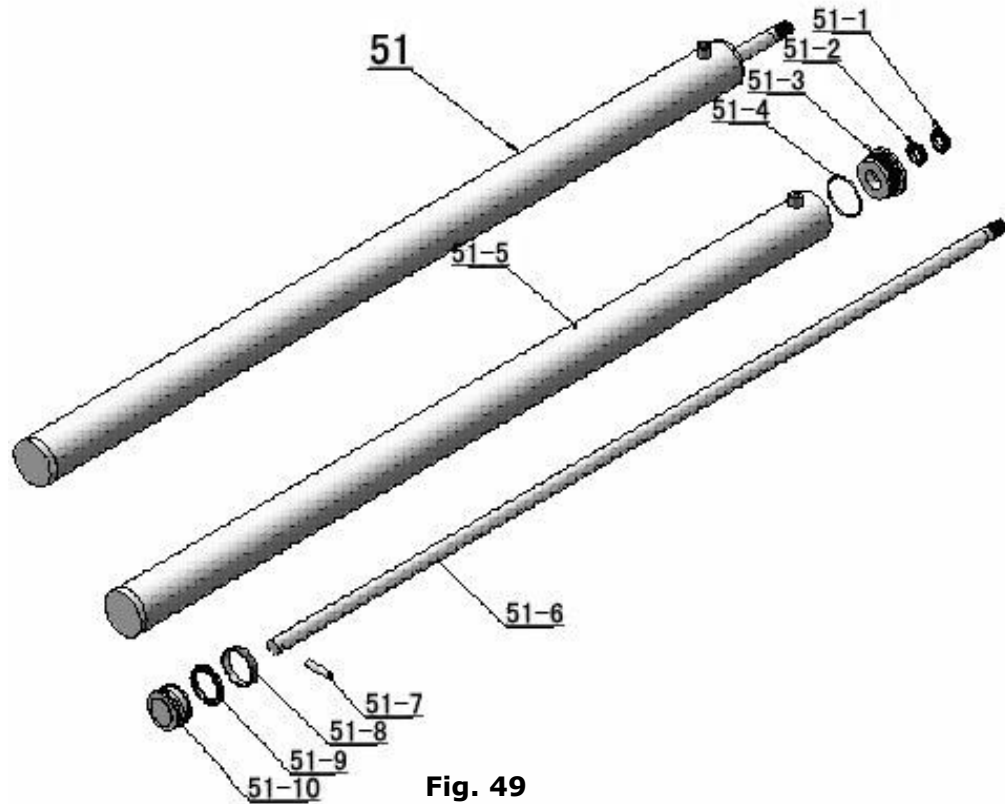

Fig. 49

Item	Part#	Description	Qty	Note
51-1	10420059	Dust Ring	1	
51-2	10420060	Y- Ring IDI	1	
51-3	11410082	Head Cap	1	
51-4	10410083	O- Ring	1	
51-5	11410084	Bore Weldment	1	
51-6	11420064	Piston Rod	1	
51-7	11410085	Pin	1	
51-8	10410086	Support Ring	1	
51-9	10410087	Y- Ring OSI	1	
51-10	11410088	Piston	1	

4.3 Power unit (071101) explosive view

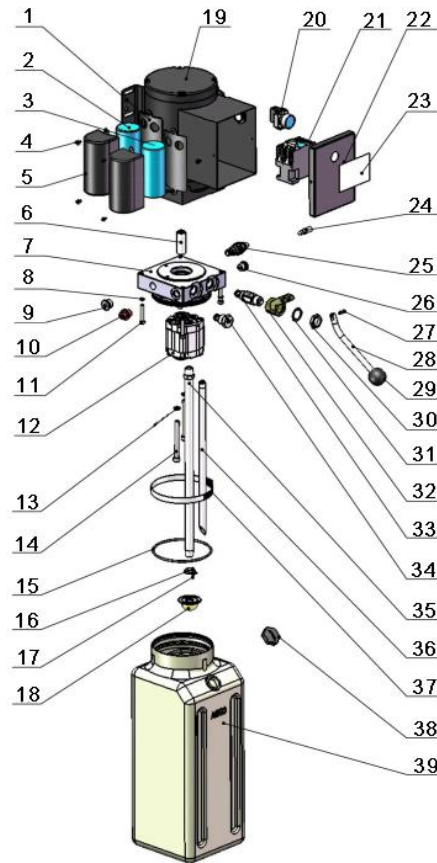
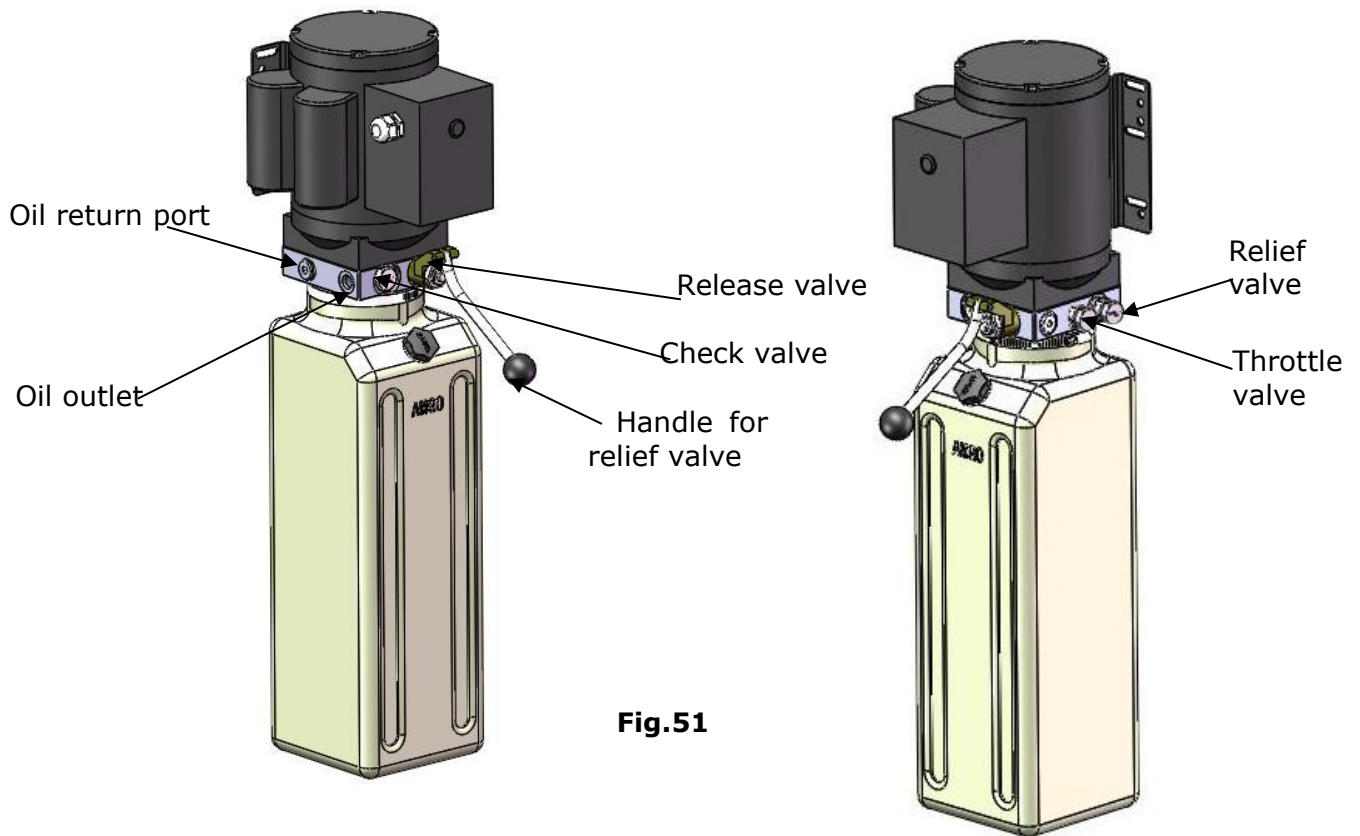

Fig. 50

Single phase, 220V/60Hz

No	Part no	Name	QTY	No	Part no	Name	QTY
1	81400180	Rubber pad	2	21	41030055	AC contractor	1
2	81400250	Starting capacitor	1	22	81400287	AC contractor	1
3	81400200	Running capacitor	1	23	71111216	Motor wiring cover	1
4	10420148	Screw with washer	4	24	814005600	Throttle valve	1
5	81400066	Capacitor cover	2	25	81400266	Relief valve	1
6	81400363	Motor connector	1	26	81400284	Plug	1
7	80101013	Manifold block	1	27	10720118	Elastic pin	1
8	10209149	Washer	4	28	81400451	Release handle	1
9	81400276	Iron Plug	1	29	10209020	Plastic ball for release handle	1
10	81400259	Red rubber plug	1	30	81400421	Release valve nut	1
11	85090142	Socket bolt	4	31	81400422	Release handle	1
12	81400280	Gear pump	1	32	81400449	Valve seat(low)	1
13	10209034	Lock washer	2	33	81400567	Release valve	1
14	81400295	Socket nut	2	34	81400566	Check washer	1
15	81400365	O-ring	1	35	81400288	Oil suction hose	1
16	10209152	Ties	1	36	81400289	Oil return hose	1
17	85090167	Magnet	1	37	81400364	Clamp(stainless steel)	1
18	81400290	Filter net	1	38	81400263	Oil tank cap	1
19	81400413	Steel Motor	1	39	81400275	Oil tank	1
20	10420070	Button switch	1				

Illustration of hydraulic valve for power unit



4.3.1 Adjust the lower speed

You can adjust the lower speed of the lift if needing: Turn the Throttle Valve in clockwise direction to decrease the lower speed, or increase the speed in counterclockwise direction.

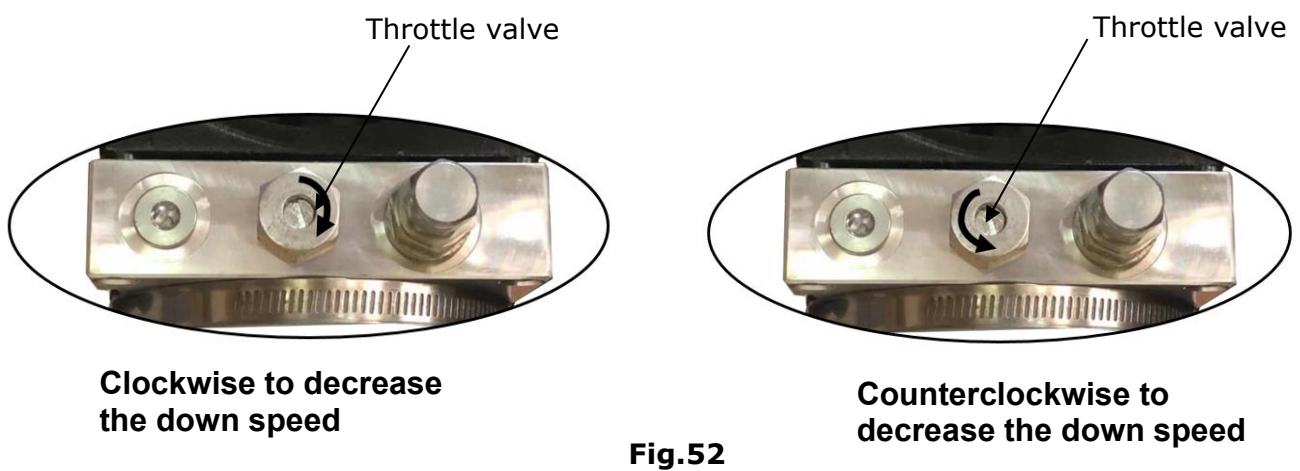

V. TEST RUN

1. Fill the reservoir with approximately 11 L Hydraulic Oil (**Note:** In consideration of Power Unit's durability, please use **Hydraulic Oil 46#**).
2. Press button **UP**, the Cables will be strained. Check whether the Cables match the Pulley. Make sure the Cables are not across.
3. Press the Handle of release valve to lock the Cross-beam to the safety ladders, and then adjust the platforms to be level by adjusting the nuts of Safety Ladders.
4. Adjust the cable fitting Hex nuts to make platforms and four safety locks work synchronously. You need to run the lift up and down for several times, meanwhile do the synchronous adjustment till the four Safety Devices can lock and release at the same time.
5. Adjust the clearance between the post and the plastic slider of Cross-beam to about 2mm, and then tighten the fixing nut of slider.
6. After finishing the above adjustment, test running the lift with load. Run the lift with Platforms in low position first, make sure the Platforms can rise and lower synchronously and the Safety Device can lock and release synchronously. And then test run the lift to the top completely. If there are anything improper, repeat the above adjustment.

Circuit Diagram of Hydraulic System

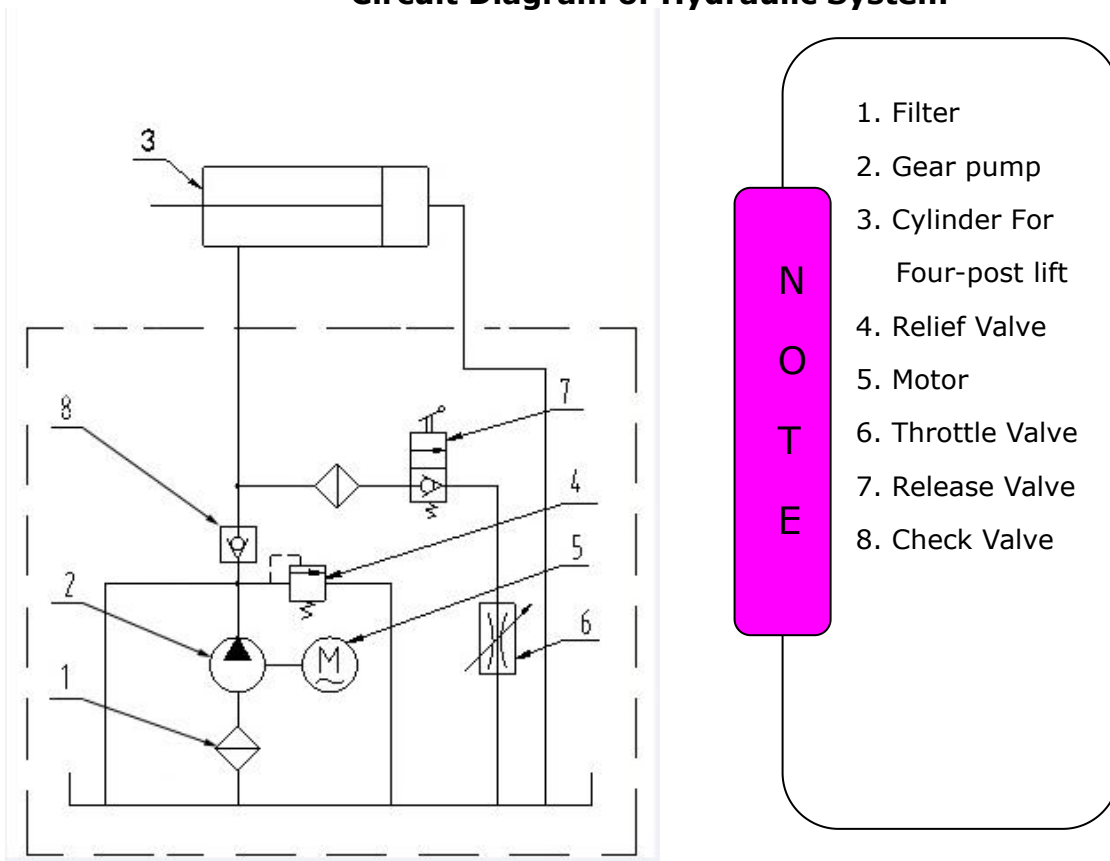

Fig. 54

VI. OPERATION INSTRUCTIONS

To lift vehicle

1. Keep clean of environment near the lift;
2. Drive vehicle to the Platform and put on the brake;
3. Turn on the power and press the button **UP**, raise the lift to the working position;
Note: make sure the vehicle is steady when the lift is raised.
4. Press the Handle of release valve to lock the lift in the safety position. Make sure the Safety device is locked at the same height.

To lower vehicle

1. Be sure the clearance of around and under the lift, only leaving operator in lift area;
2. Press the button **UP**, the lift will be raised for 3-5 seconds, and then press the button of Manual-controlled air valve by hand to make sure the safety device released, press the handle of release valve by the other hand then the lift starts being lowered automatically;
3. Drive away the vehicle when the lift is lowered to the lowest position.
4. Turn off the power.

VII. MAINTENANCE SCHEDULE

Monthly:

1. Re-torque the anchor bolts to 150Nm;
2. Lubricate cable with lubricant;
3. Check all cable connection, bolts and pins to insure proper mounting;
4. Make a visual inspection of all hydraulic hoses/lines for possible wear or leakage;
5. Lubricate all Rollers, Safety devices with 90wt. gear oil or equivalent.

Note: All anchor bolts should take full torque. If any of the bolts does not function for any reason, DO NOT use the lift until the bolt has been replaced.

Every six months:

1. Make a visual inspection of all moving parts for possible wear, interference or damage.
2. Check and adjust as necessary, equalizer tension to insure level lifting.
3. Check columns for plumbness.

Oil cylinder maintenance:

In order to extend the service life of the oil cylinder, please operate according to the following requirements.

1. Recommend to use N46 anti-wear hydraulic oil.
2. The hydraulic oil of the lifts should be replaced regularly during using. Replace the hydraulic oil 3 months after the first installation, Replace the hydraulic oil once a year afterwards.
3. Make at least one full trip raising and lowering per day. For exhausting the air from the system, which could effectively avoid the corrosion of the cylinder and damage to the seals caused by presence of air or water in the system.
4. Protect the outer surface of the oil cylinder's piston rod from bumping and scratching, and timely clean up the debris on the oil cylinder dust-ring and the piston rod.

VIII. TROUBLE SHOOTING

TROUBLE	CAUSE	REMEDY
Motor does not run	<ol style="list-style-type: none"> 1. Button does not work 2. Wiring connections are not in good condition 3. Motor burned out 4. AC contactor burned out 5. Height limit switch is damaged 	<ol style="list-style-type: none"> 1. Replace button 2. Repair all wiring connections 3. Repair or replace motor 4. Replace AC contactor 5. Replace
Motor runs but the lift is not raised	<ol style="list-style-type: none"> 1. Motor runs in reverse rotation 2. Release valve in damage 3. Gear pump in damage 4. Relief valve or check valve in damage 5. Low oil level 	<ol style="list-style-type: none"> 1. Reverse two power wire 2. Repair or replace 3. Repair or replace 4. Repair or replace 5. Fill tank
Lift does not stay up	<ol style="list-style-type: none"> 1. Release valve out of work 2. Relief valve or check valve leakage. 3. Cylinder or fittings leaks 	Repair or replace
Lift raises too slow	<ol style="list-style-type: none"> 1. Oil line is jammed 2. Motor running on low voltage 3. Oil mixed with Air 4. Pump leaks 5. Overload lifting 	<ol style="list-style-type: none"> 1. Clean the oil line 2. Check electrical system 3. Fill tank 4. Replace Pump 5. Check load
Lift cannot lower	<ol style="list-style-type: none"> 1. Safety device are in activated 2. Release valve damaged 3. Air Cylinder damaged 4. Oil system is jammed 	<ol style="list-style-type: none"> 1. Release the safeties 2. Replace or repair 3. Replace the cylinder 4. Clean the oil system

IX. LIFT DISPOSAL:

When the car lift cannot meet the requirements for normal use and needs to be disposed, it should follow local laws and regulations.



AMGO HYDRAULIC CORPORATION

1931 Joe Rogers Blvd, Manning, South Carolina, USA

Zip: 29102

Tel: (803) 505-6410

Fax: (803) 505-6410

Manual No.: 72247502

Revised Date: 2022.05