

AMGO  [®] **Hydraulics**

Original

Installation And Service Manual



TWO POST LIFT
Model: OHX-10/OHX-10H

CONTENTS

Product Features and Specifications	1
Installation Requirement	5
Steps of Installation	6
Exploded View	33
Test Run	41
Operation Instruction	43
Maintenance	43
Trouble Shooting	45
Lift disposal	45

I. PRODUCT FEATURES AND SPECIFICATIONS

CLEAR-FLOOR DIRECT-DRIVED MODEL FEATURES

Model OHX-10 (See Fig. 1)

- Direct-driven design, minimize the lift wear parts and breakdown ratio
- Dual hydraulic cylinders, designed and made as USA standards, utilizing oil seal in cylinder
- Self-lubricating UHMW Polyethylene sliders and bronze bush
- Single-point safety release, and dual safety design
- Clear-floor design, provide unobstructed floor space
- Overhead safety shut-off device prevents vehicle damages
- Stackable rubber pads

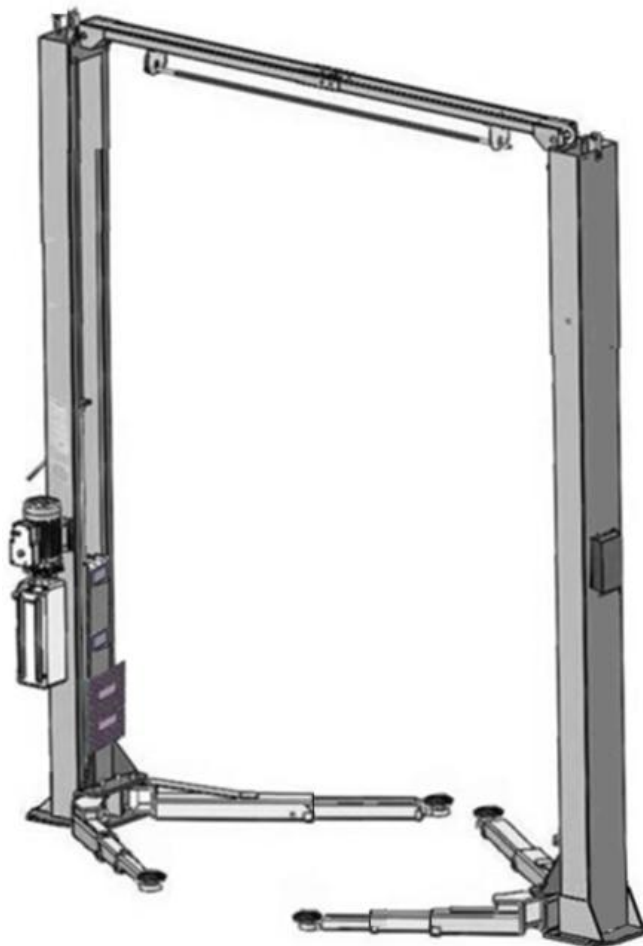

Fig. 1

SPECIFICATIONS

Model	Lifting Capacity	Lifting Time	Lifting Height	Overall Height	Overall Width	Minimum Pad Height	Motor
OHX-10	10000lbs	57S	71-1/2"~80-1/2"	144"	135"	3-1/2"~12-1/2"	2.0HP

Model OHX-10H (See Fig. 2)

- Direct-driven design, minimize the lift wear parts and breakdown ratio
- Dual hydraulic cylinders, designed and made as USA standards, utilizing oil seal in cylinder
- Self-lubricating UHMW Polyethylene sliders and bronze bush
- Single-point safety release, and dual safety design
- Clear-floor design, provide unobstructed floor space
- Overhead safety shut-off device prevents vehicle damage
- Stackable rubber pads
- Adjustable column height

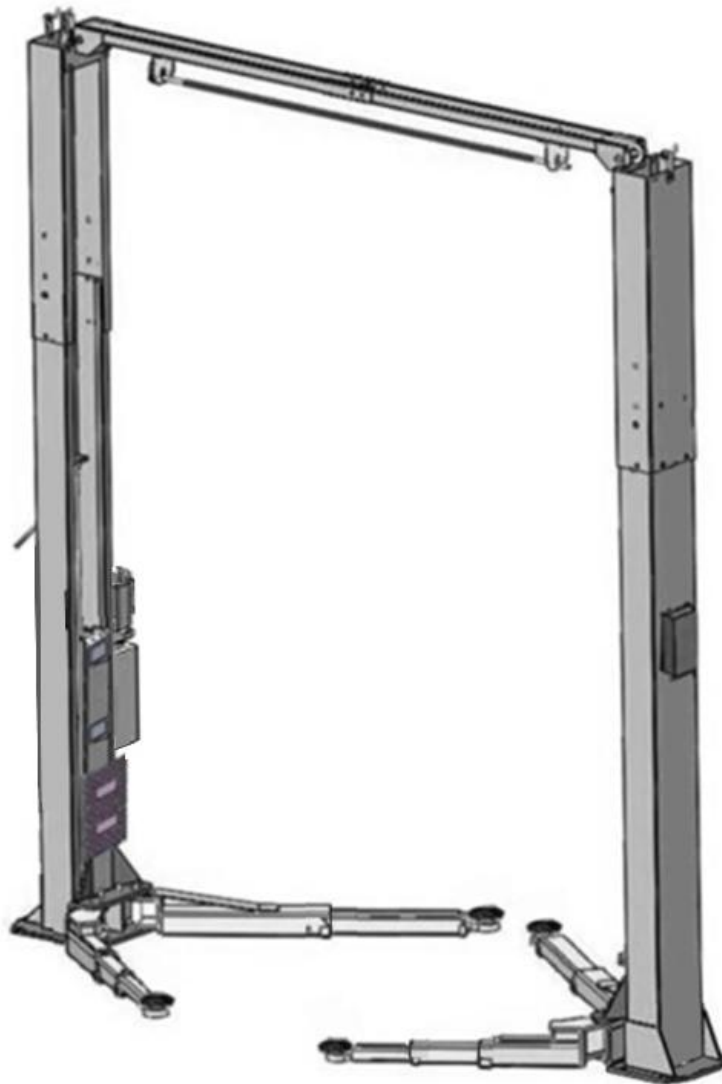

Fig. 2

SPECIFICATIONS

Model	Lifting Capacity	Lifting Time	Lifting Height	Overall Height	Overall Width	Minimum Pad Height	Motor
OHX-10H	10000lbs	63s	78-1/2"~87-1/2"	157"/168"	135"	3-1/2"~12-1/2"	2.0HP

Arm Swings View

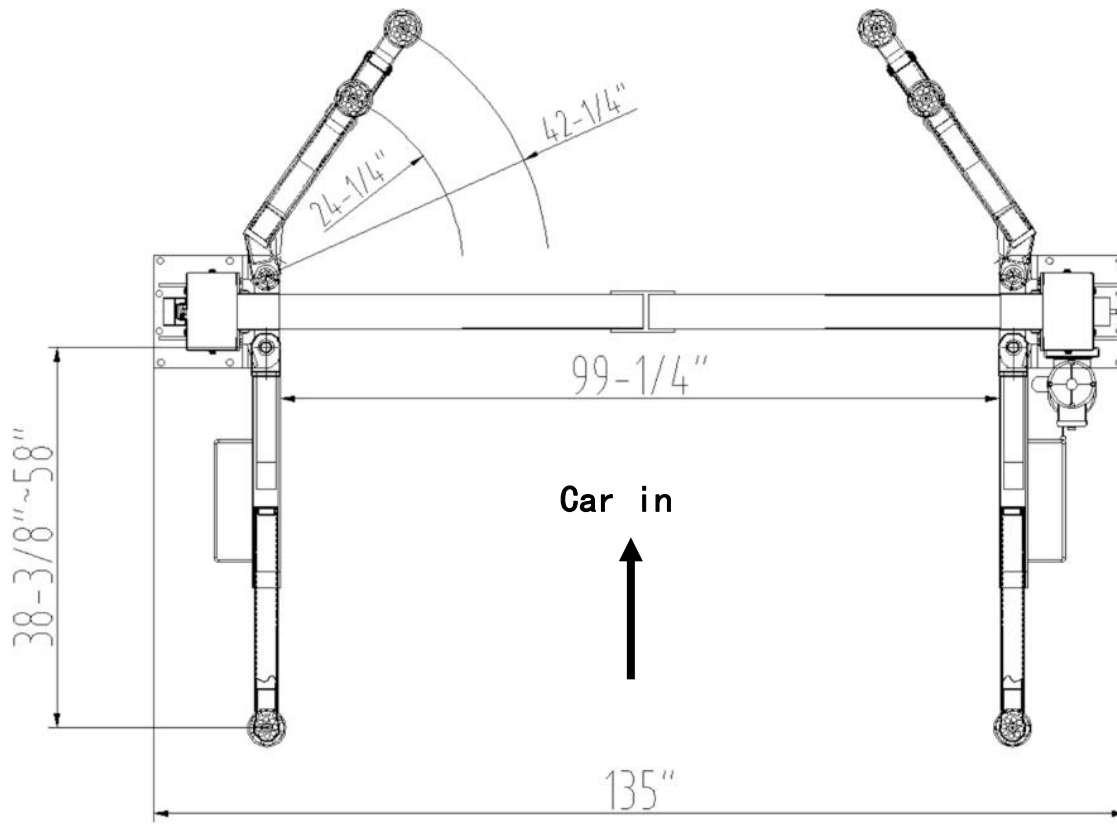

Fig. 3

Swing and extending the arms to the lifting point of vehicle

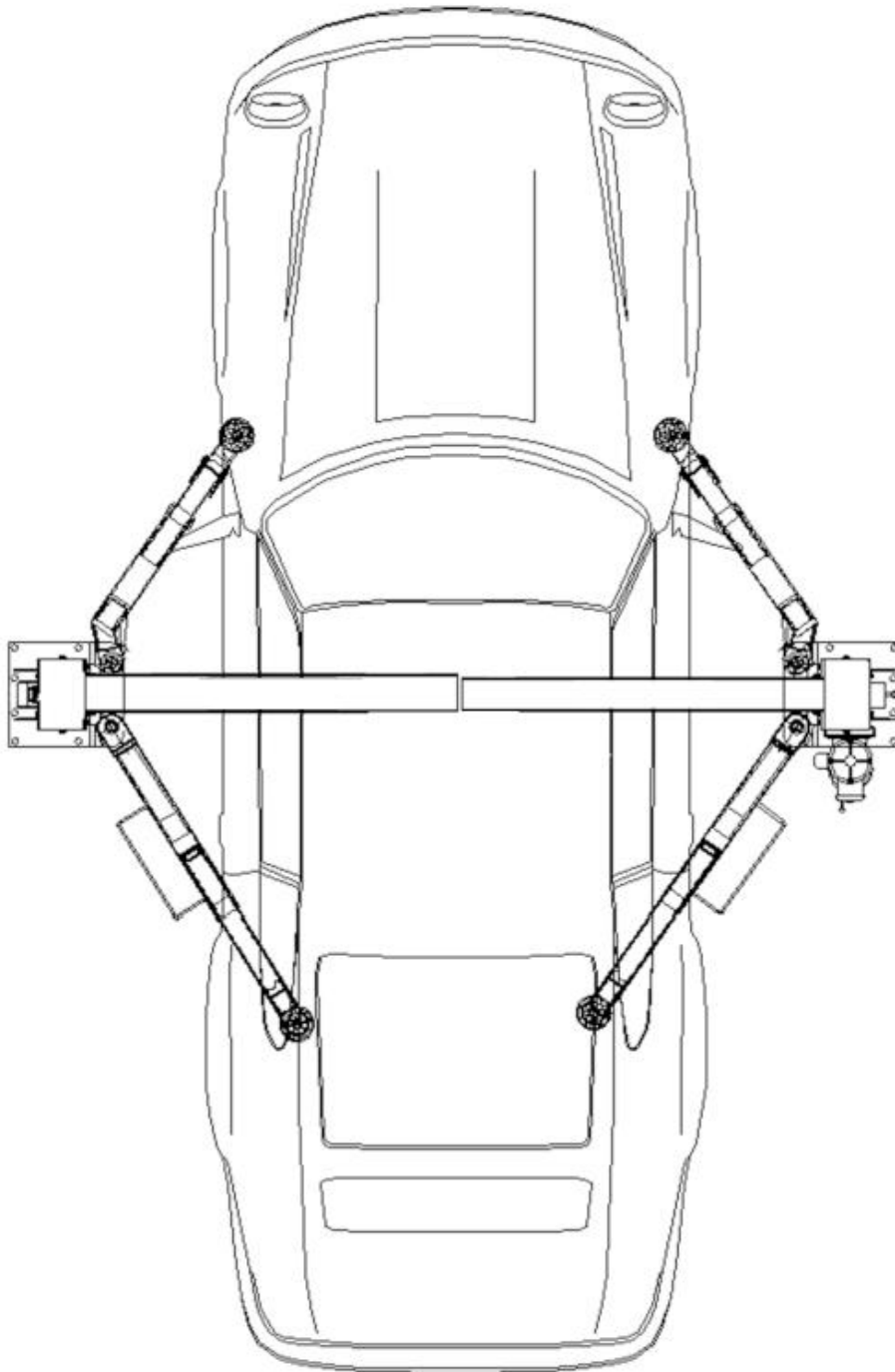

Fig. 4

II. INSTALLATION REQUIREMENT

A. TOOLS REQUIRED

- ✓ Rotary Hammer Drill ($\Phi 3/4$)



- ✓ Hammer



- ✓ Level Bar



- ✓ English Spanner (12")



- ✓ Ratchet Spanner with Socket (28#)



- ✓ Wrench set

(10#, 13#, 14#, 15#, 17#, 19#, 24#, 27#)



- ✓ Carpenter's Chalk



- ✓ Screw Sets



- ✓ Tape Measure (7.5m)



- ✓ Pliers



- ✓ Socket Head Wrench (6#)



- ✓ Lock Wrench



Fig. 5

B. SPECIFICATIONS OF CONCRETE (See Fig. 6)

Specifications of concrete must be adhered to the specification as following.
Failure to do so may result in lift and/or vehicle falling.

1. Concrete must be thickness 4" minimum and without reinforcing steel bars, and must be dried completely before the installation.
2. Concrete must be in good condition and must be of test strength 3,000psi minimum.
3. Floors must be level without cracks.

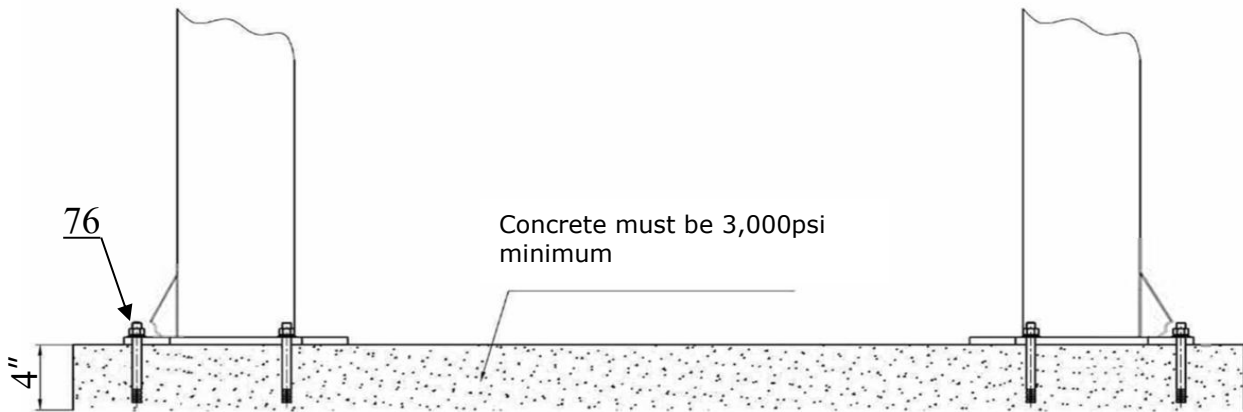

Fig. 6

C. POWER SUPPLY

The electrical source must be 2.0HP minimum. The source cable size must be 2.5mm² and in good condition of contacting with floor.

III. STEPS OF INSTALLATION

A. Location of Installation

Check and insure the installation location (concrete, layout, space size etc.) is suitable for lift installation.

B. Use a carpenter's chalk line to establish installation layout of base-plate (See Fig.7).

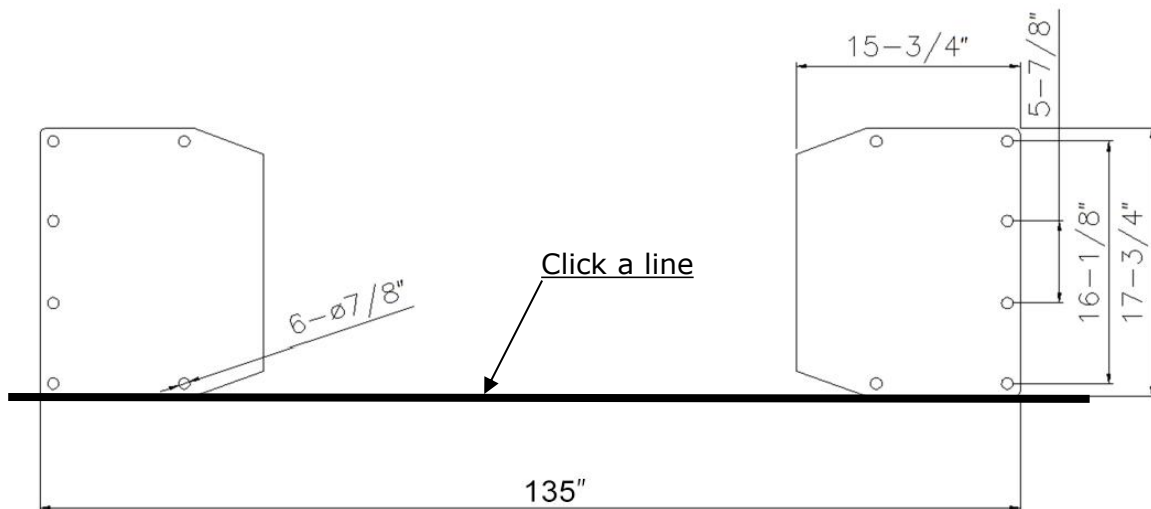

Fig. 7

C. Check the parts before assembly.

1. Packaged lift and hydraulic power unit (See Fig. 8).



Fig. 8

2. Move aside the lift with fork lift or hoist, and open the extension packing carefully, take off the lifting arms and parts box from upper and inside the column, then move them to location nearby installation site, check the parts according to the shipment parts list (See Fig.9).

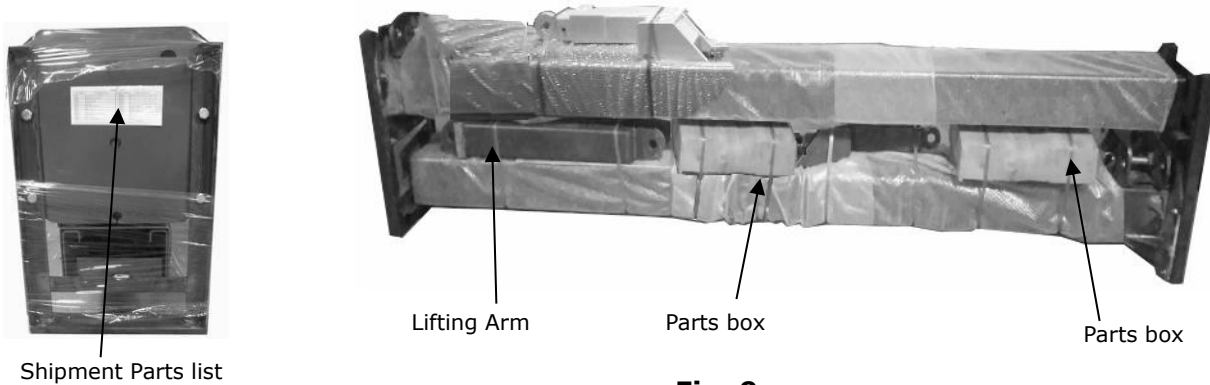

Fig. 9

3. Loose the screws of the upper package stand, take off the upper extension columns, take out the parts in the inner column and remove the package stand
4. Move aside the parts and check the parts according to the shipment parts list (See Fig.10, 11).

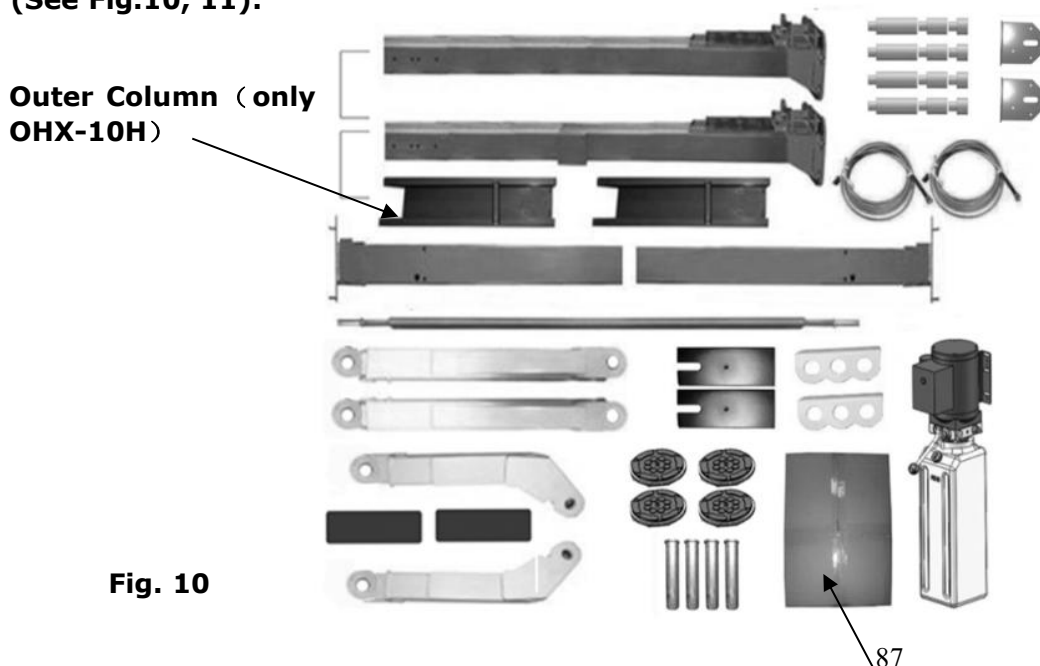

Fig. 10



84
(only OHX-10H)

Part box (87)
Fig. 11

5. Open the bag 1 of parts and check the parts according to parts box list (See Fig. 12,13).



OHX-10
Accessories
Fig. 12

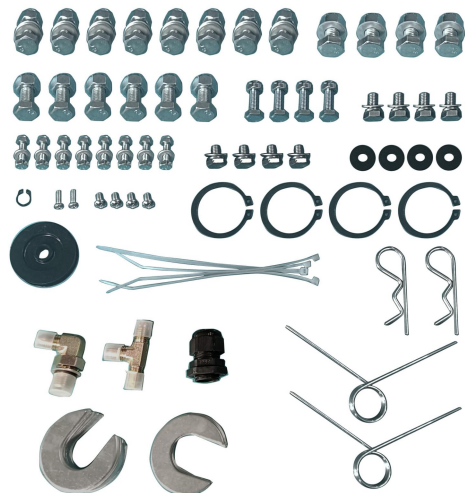

OHX-10H
Accessories
Fig. 13

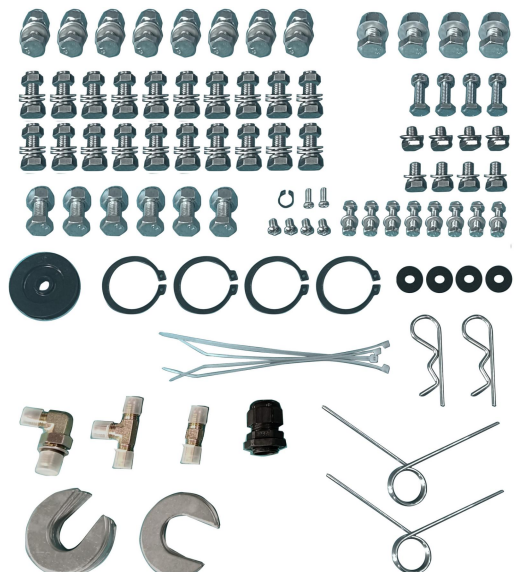

6. Open the bag 2 of parts and check the parts according to parts bag list (See Fig. 14).

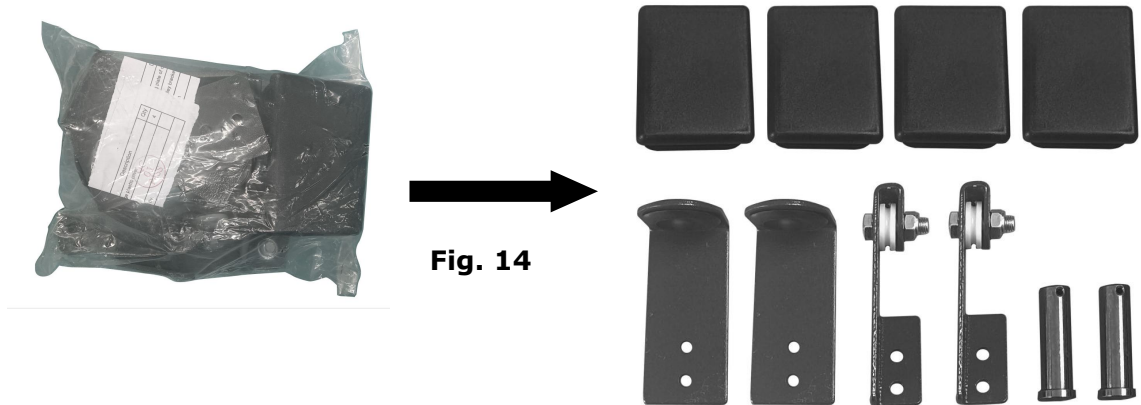

D. Place the two columns in parallel on the ground of installation position, and determine the installation position of the power side column according to the condition of the installation site. Under normal circumstances, the power side column is installed on the right side of the entering direction; then install the oil hose.

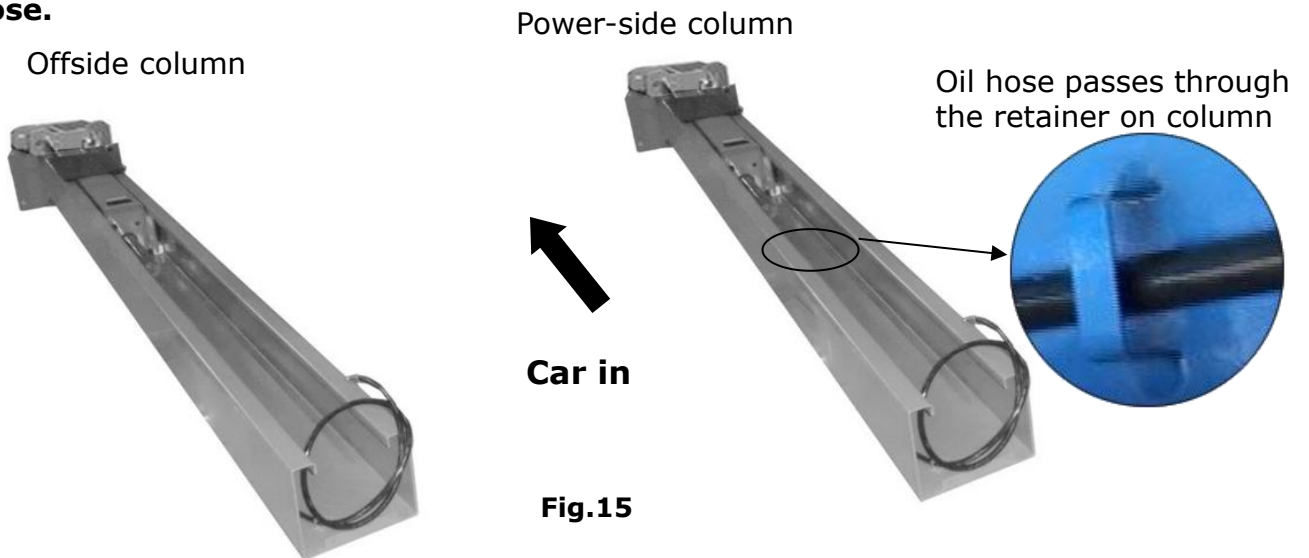

E. Install the cylinder and connect the oil hose to the cylinder.

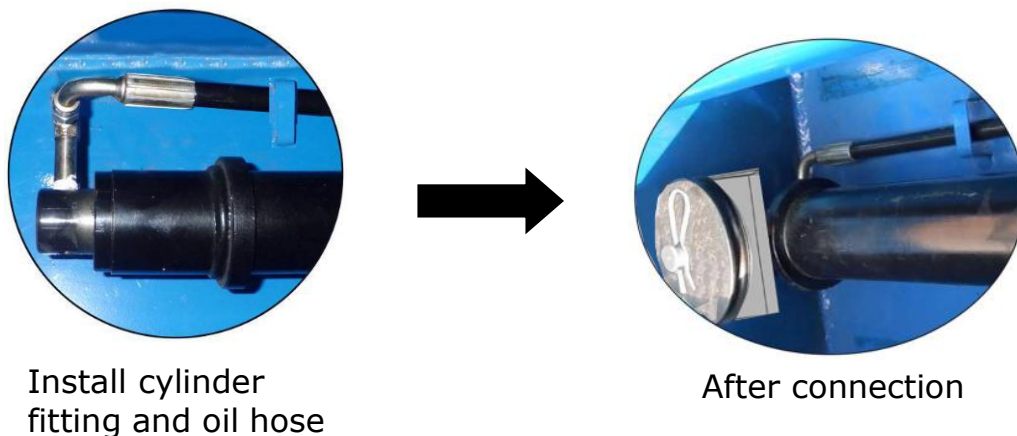

F. Mounting column assemble.

1. OHX-10 mounting column assemble. Fig.17 & 18.

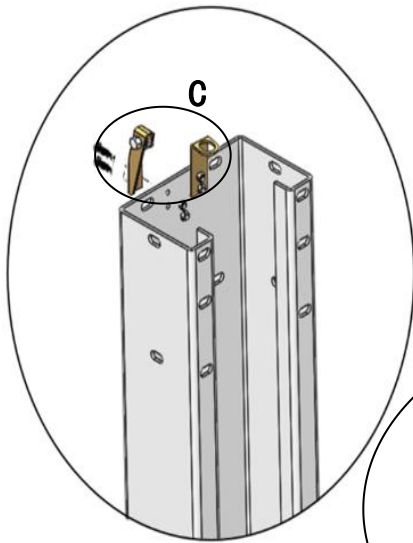

A View
Offside column
Fig. 17

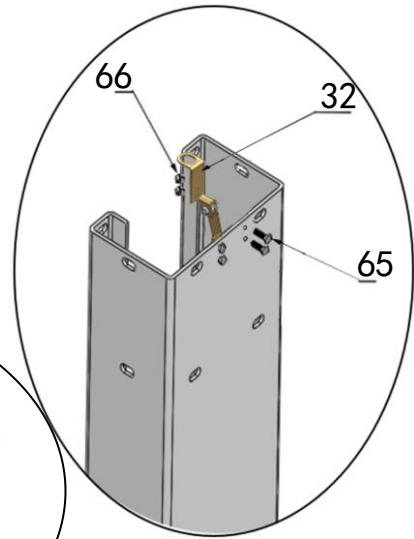
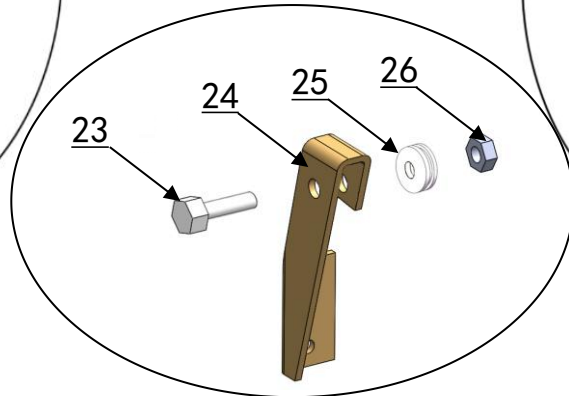

B View
power-side column
Fig. 18

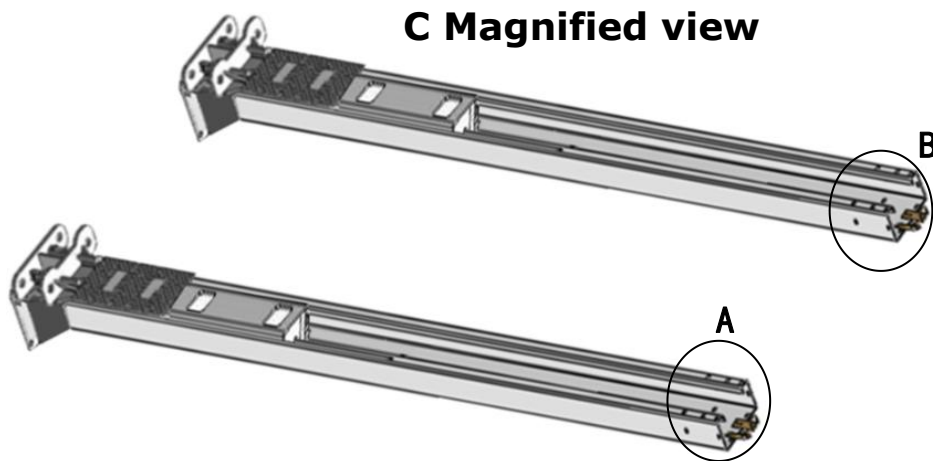

2. OHX-10H Mounting column assemble. Fig. 19

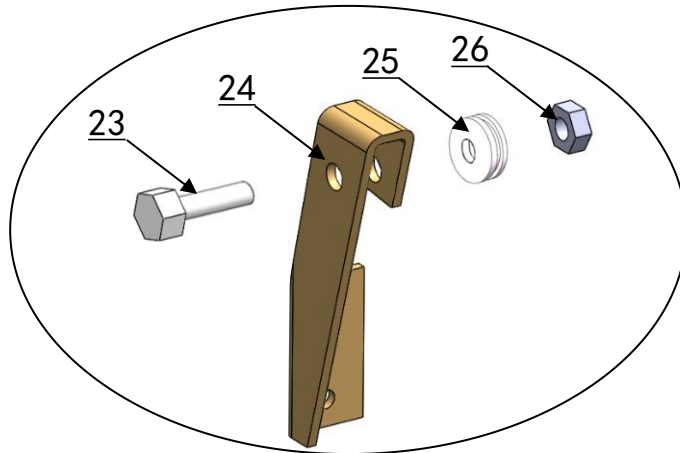

A Magnified view

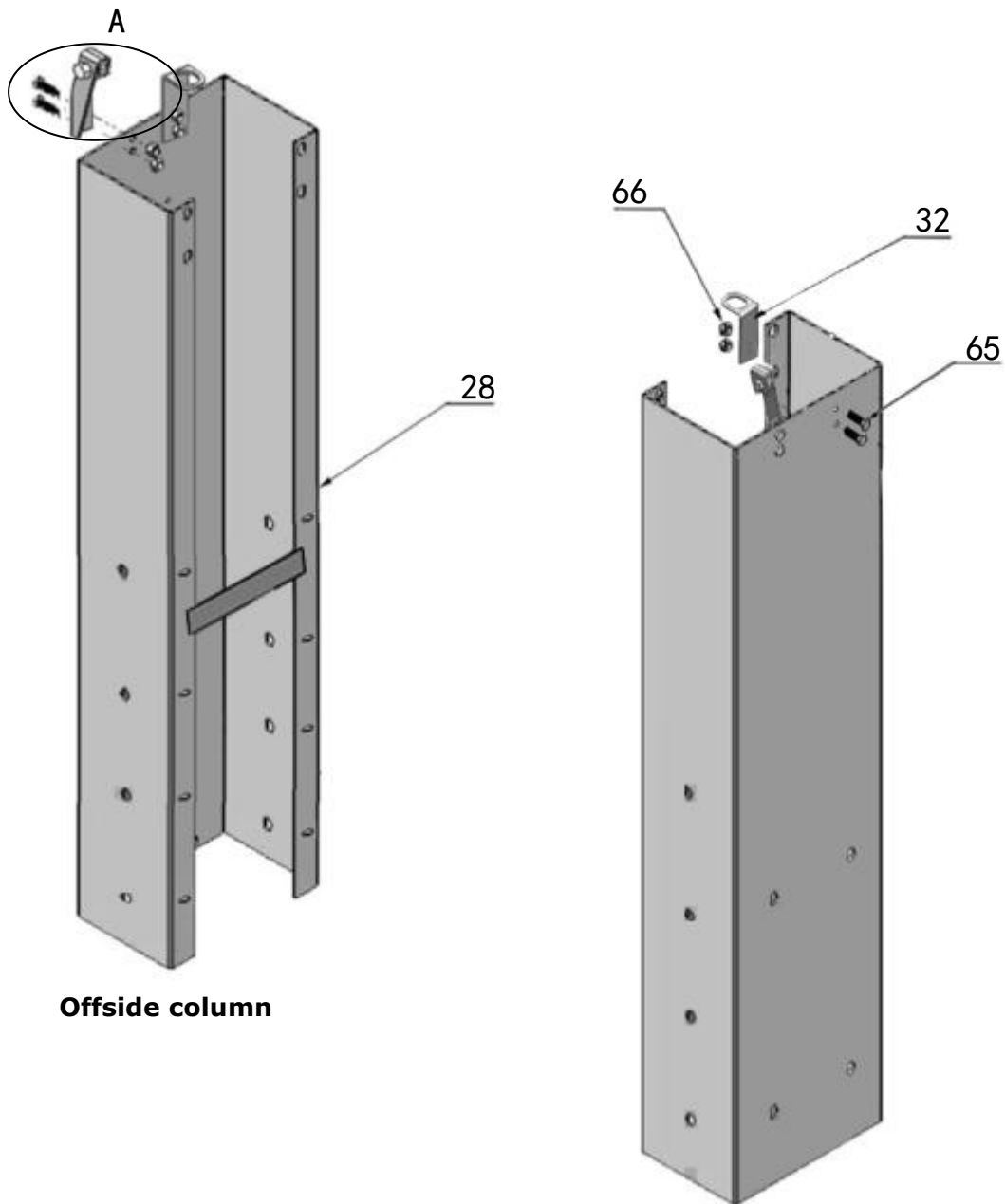

Offside column

Power-side column

Fig.19

Place the two columns in parallel on the ground of the installation position, and determine the installation position of the power-side column according to the condition of the installation site. Under normal circumstances, the power-side column is installed on the right side of the entering direction; when installing the outer column, it should be installed according to the height of the workshop. When the height is not more than 168", the mounting column is selected to install the lower position; when the height is more than 168", the mounting column can be installed with the high position. (See Fig.20)

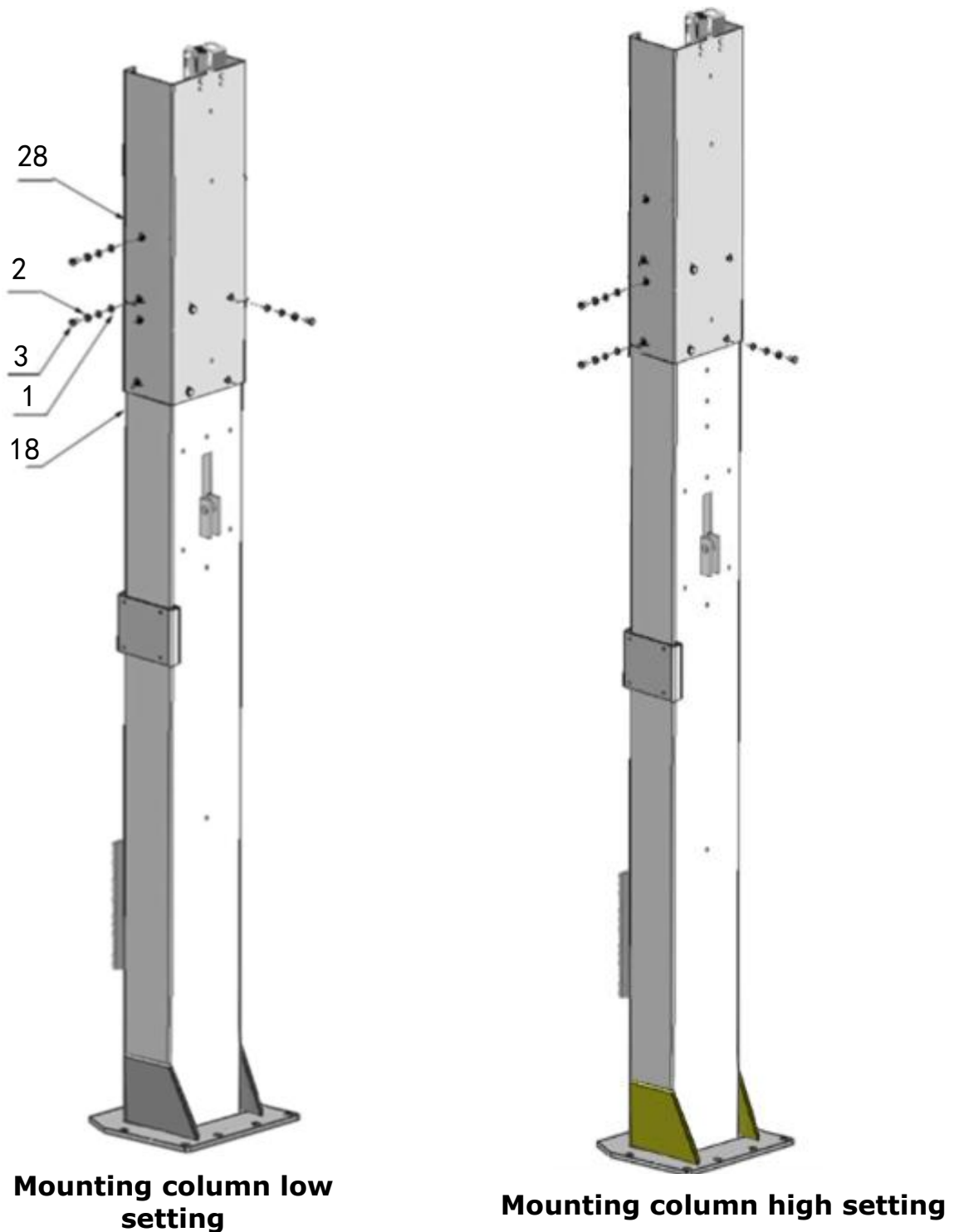
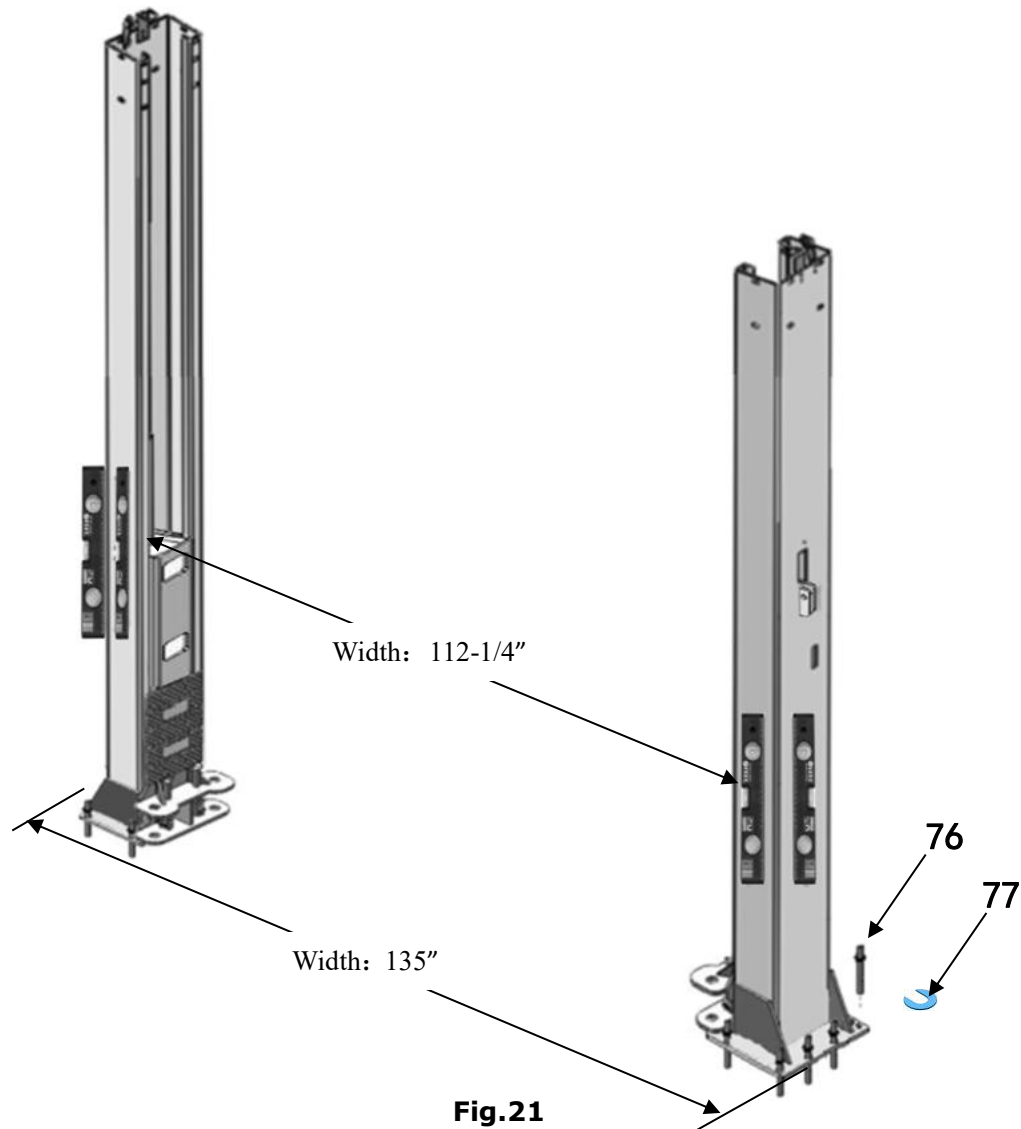

Fig.20

G. Vertical leveling of columns (See Fig. 21)

1. OHX-10

Put the columns on the installation layout of base-plate, install the anchor bolts. Check the Columns plumpness with level bar, and adjusting with the shims if the columns are not vertical. Do not tighten the Anchor Bolts.



*Note: The anchor bolt is knocked into the ground at least 3-1/2".



2. OHX-10H

Put the columns on the installation layout of base-plate, install the anchor bolts. Check the Columns plumpness with level bar, and adjusting with the shims if the columns are not vertical. Do not tighten the Anchor Bolts. (See Fig. 22)

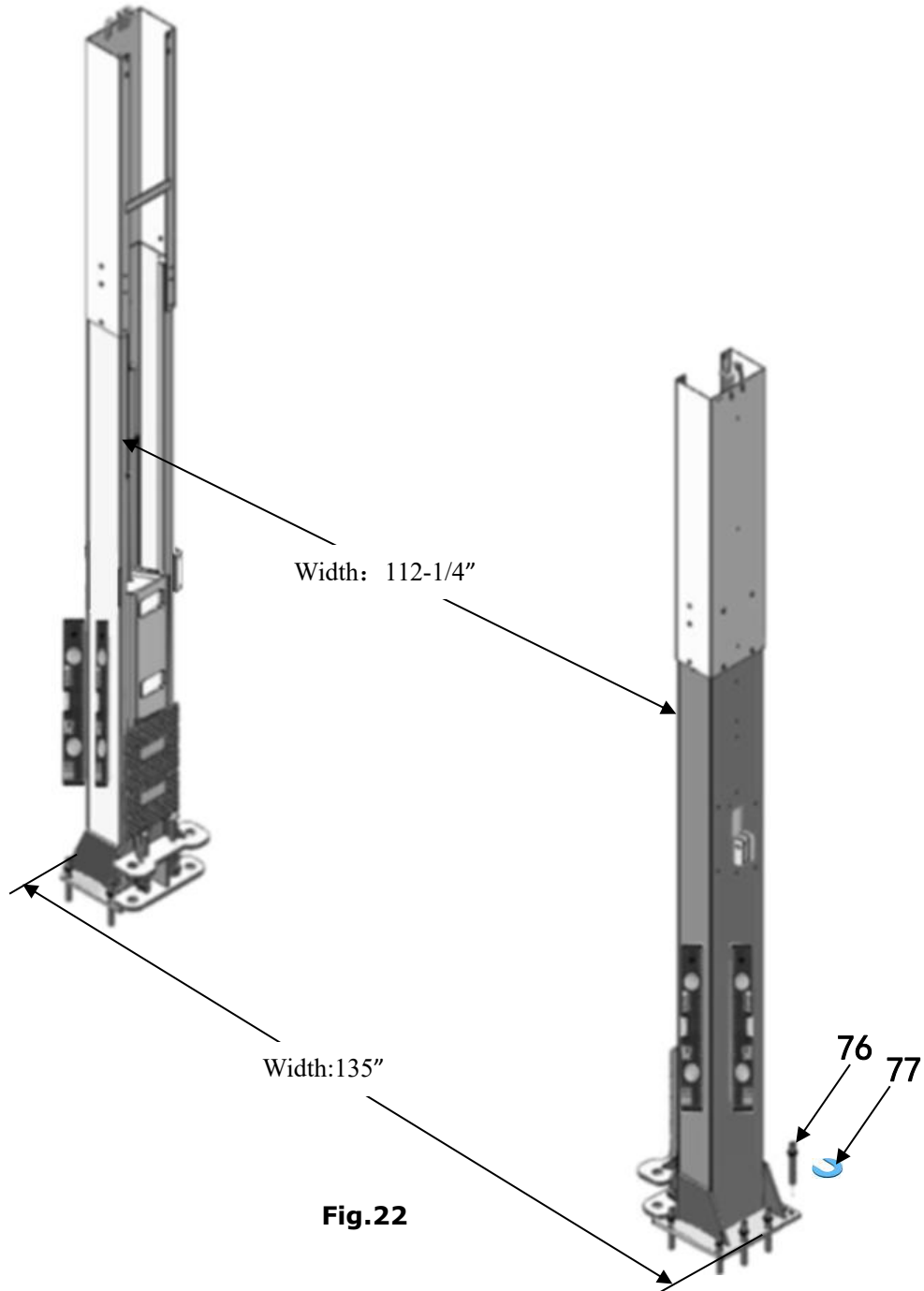

*Note: The anchor bolt is knocked into the ground at least 3-1/2".

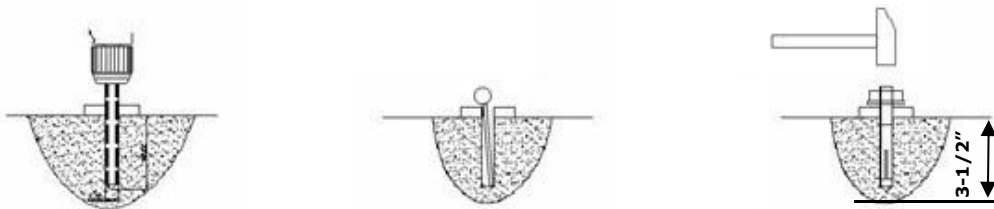

H. Install overhead top beam (See Fig. 23).

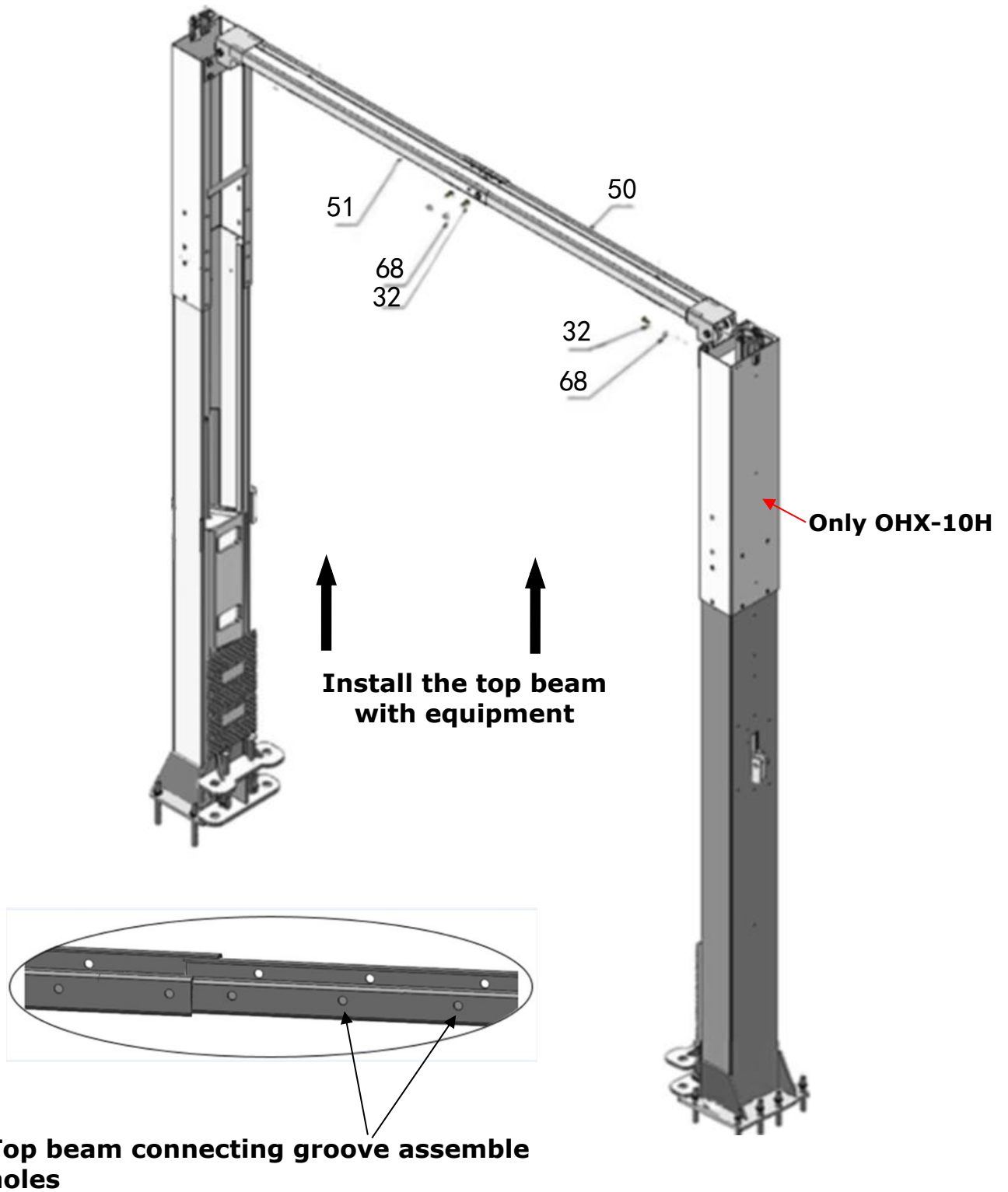

Fig.23

I. Installing the limit switch control bar and limit switch (See Fig. 24).

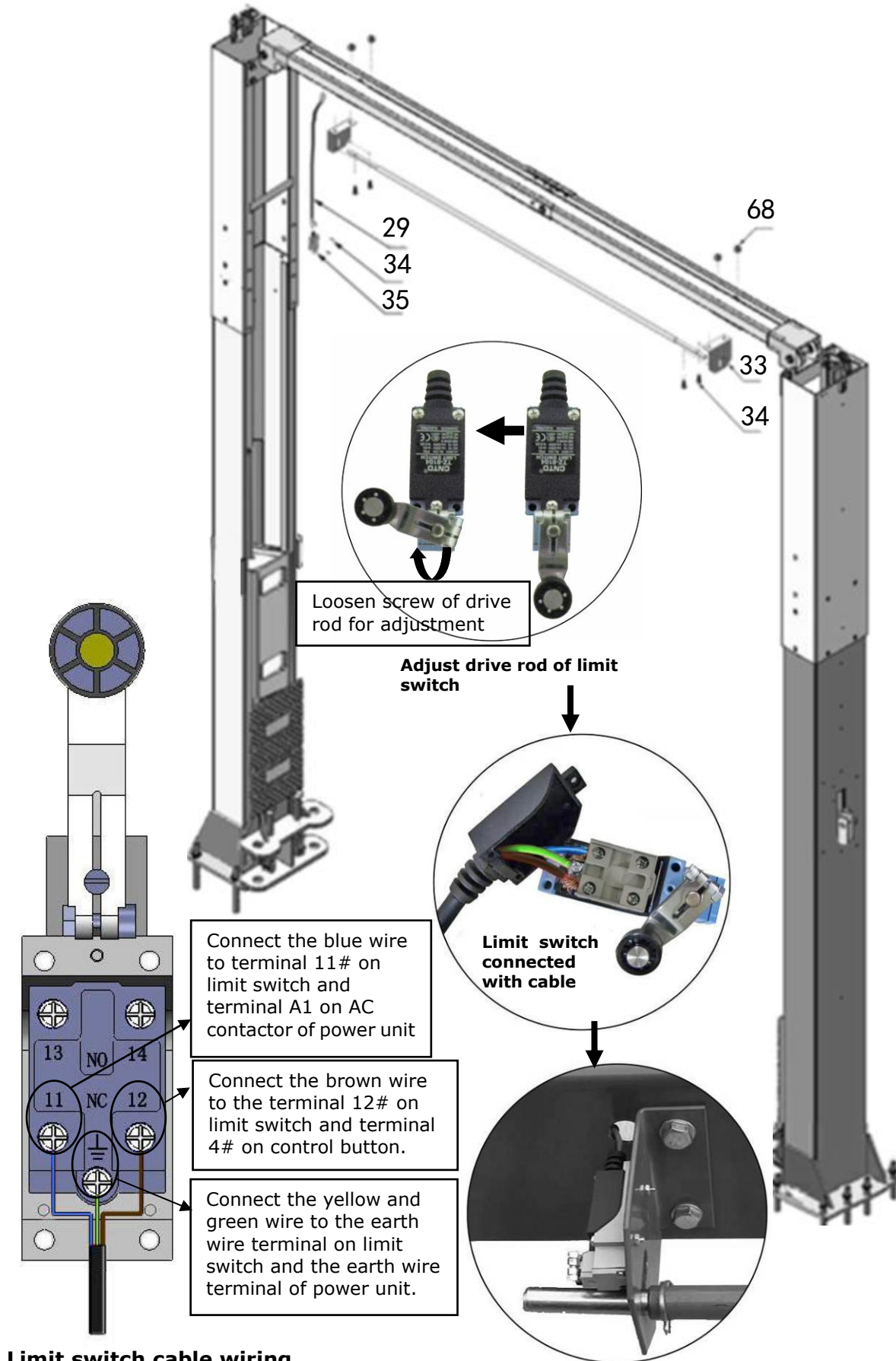

Fig. 24

I. Lift the carriages up and make them be locked at the same level (See Fig. 25).

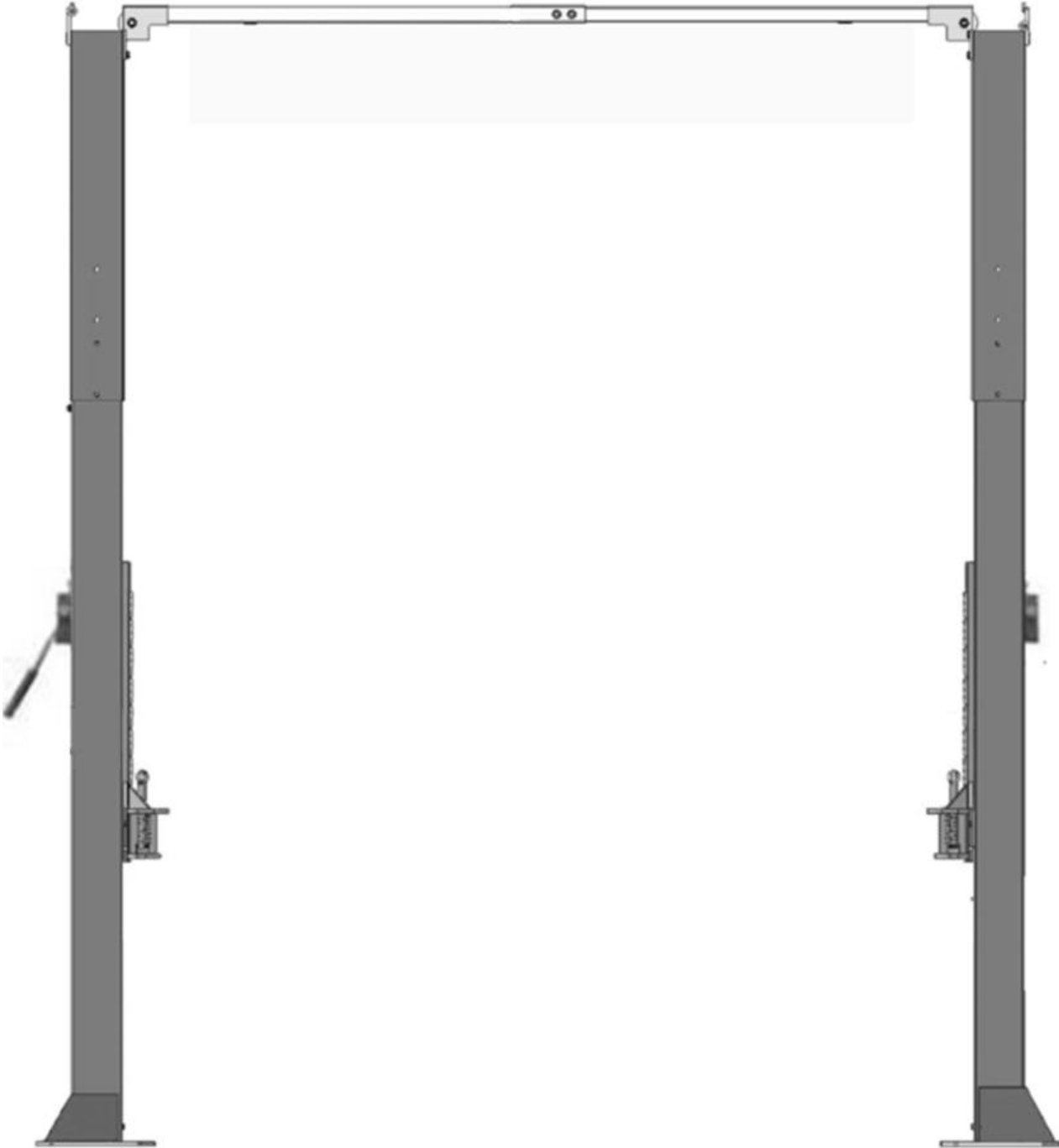

Fig.25

K. Install cables

1. OHX-10 cable connection.

Cables pass through the bottom of the carriages and be pulled out from the square hole of carriages, then screw the two cable nuts (See Fig. 26)

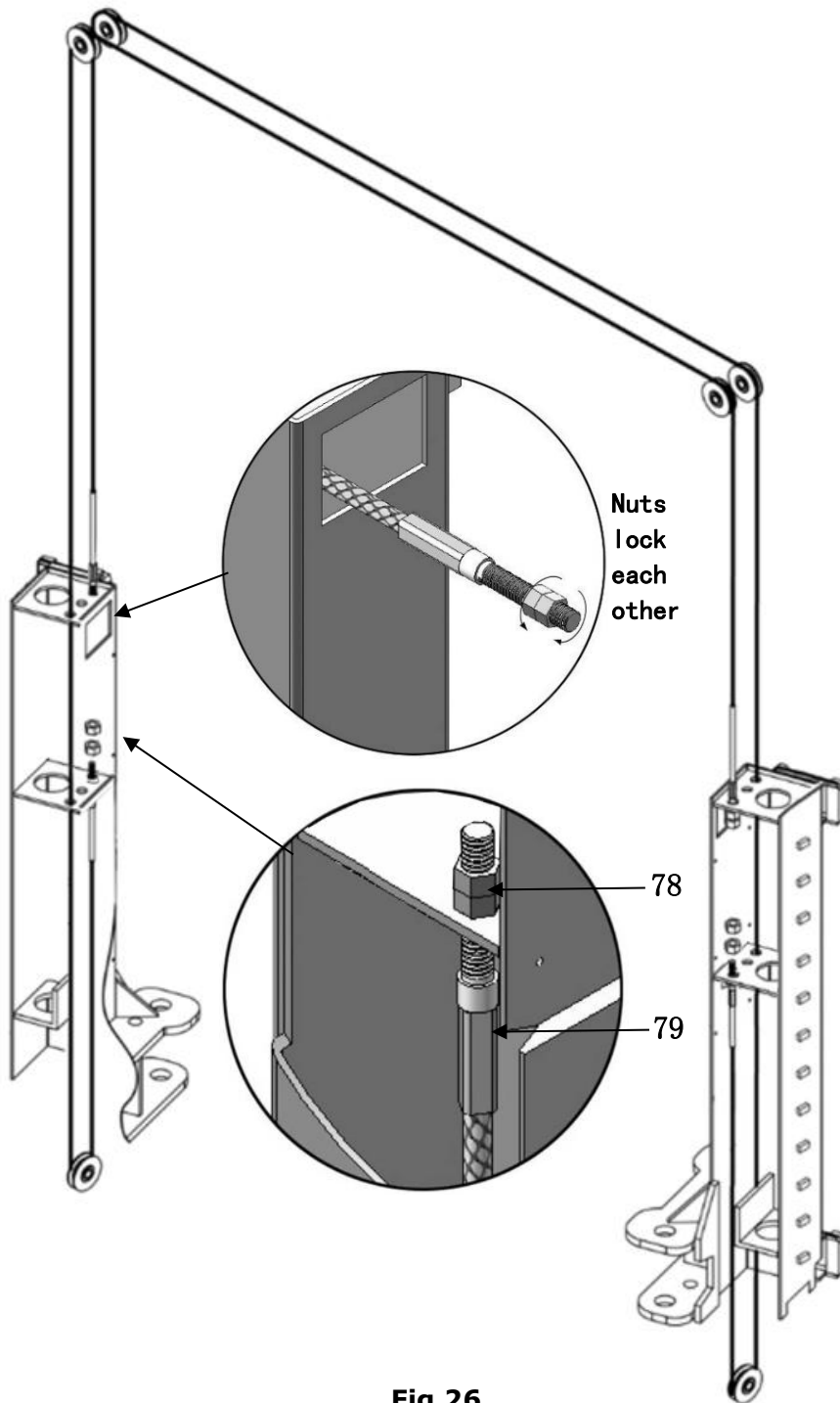

Fig.26

2. OHX-10H Low setting cable connection (See Fig. 27)

Note: the cable should go inside the carriage.

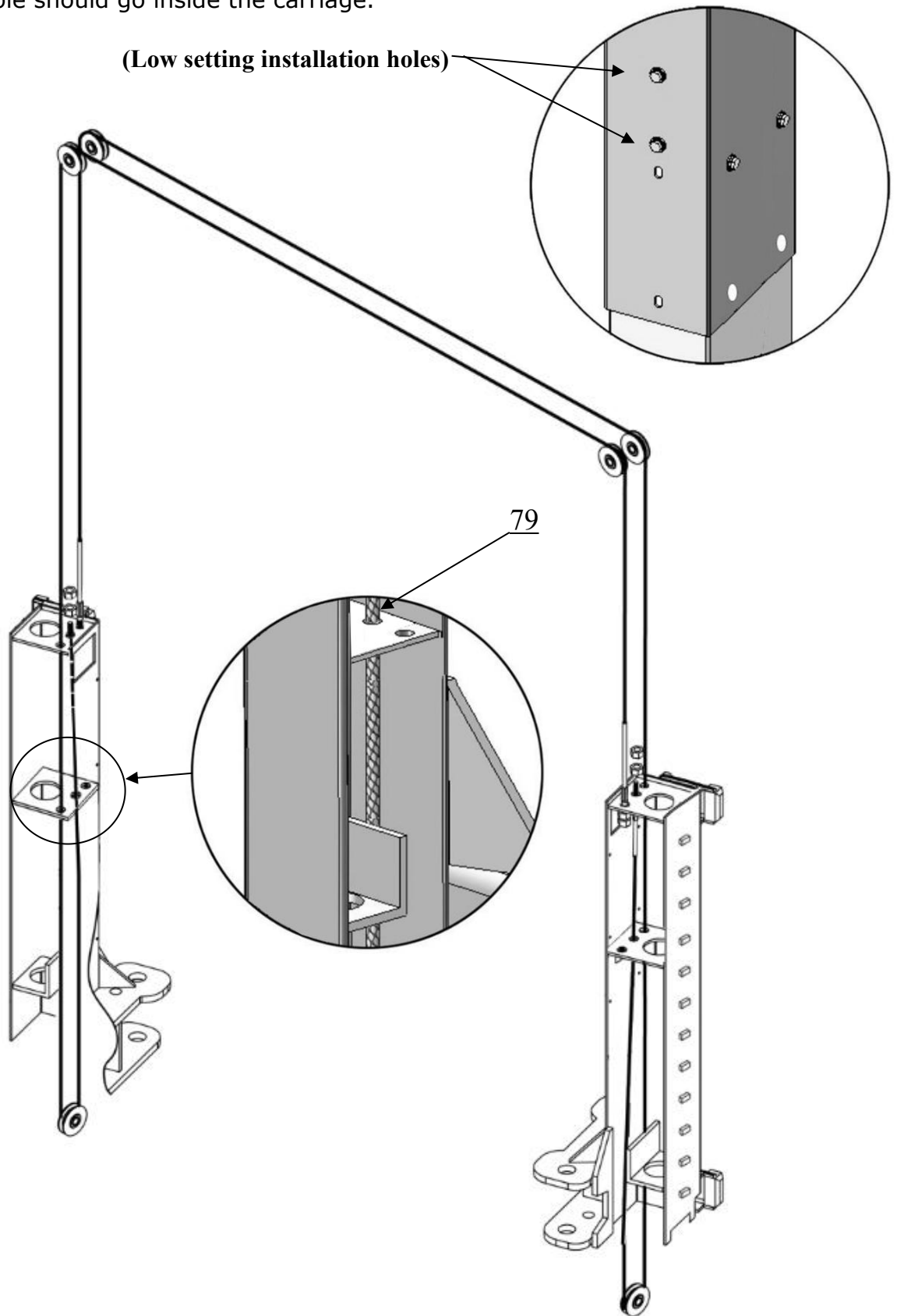

Fig.27

3. OHX-10H High setting cable connection

Cables pass through the bottom of the carriages and be pulled out from the square hole of carriages, then screw the two cable nuts (See Fig. 28).

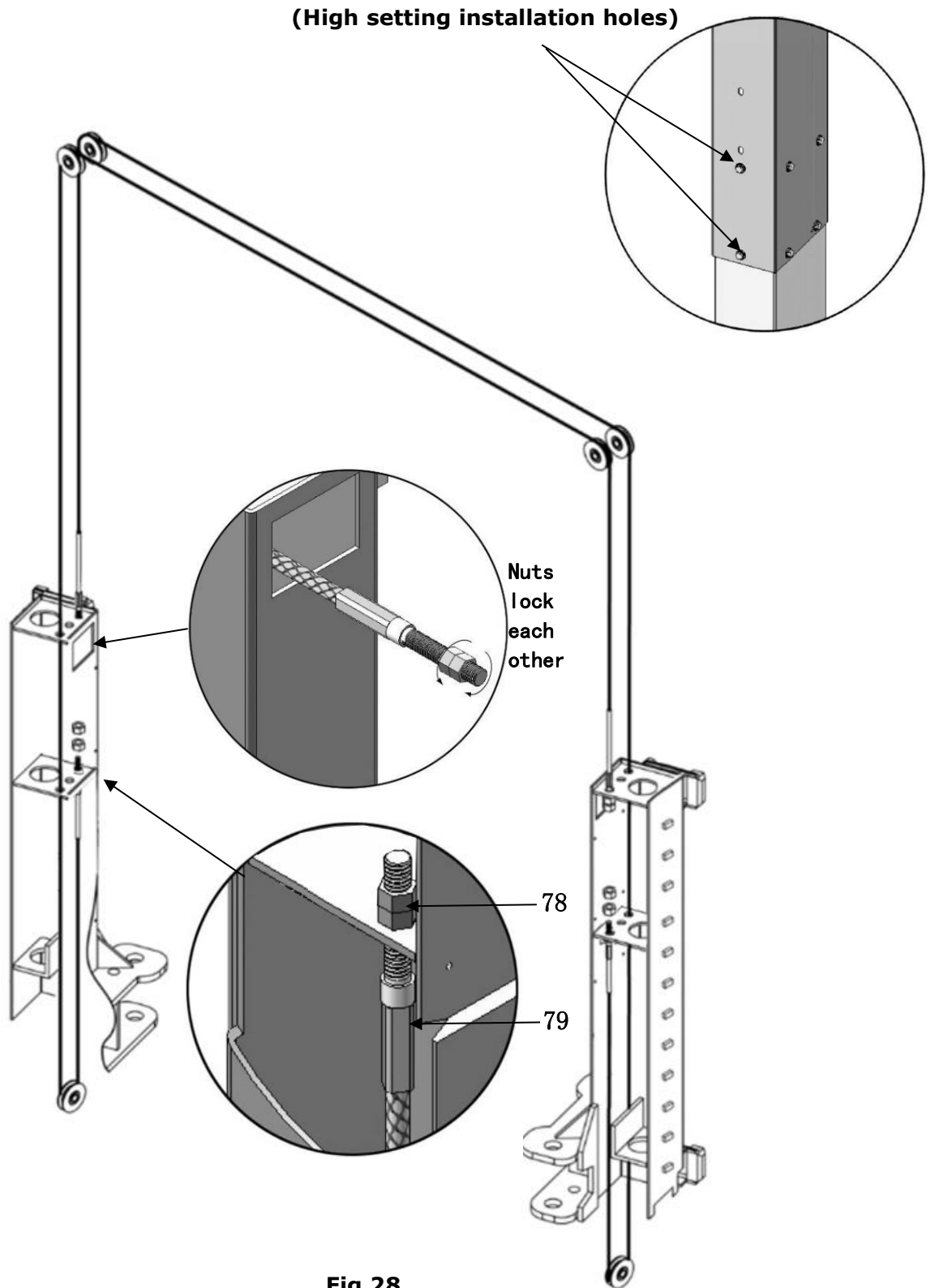

Fig.28

L. Install oil hose and fitting

1. OHX-10 (See Fig.29).

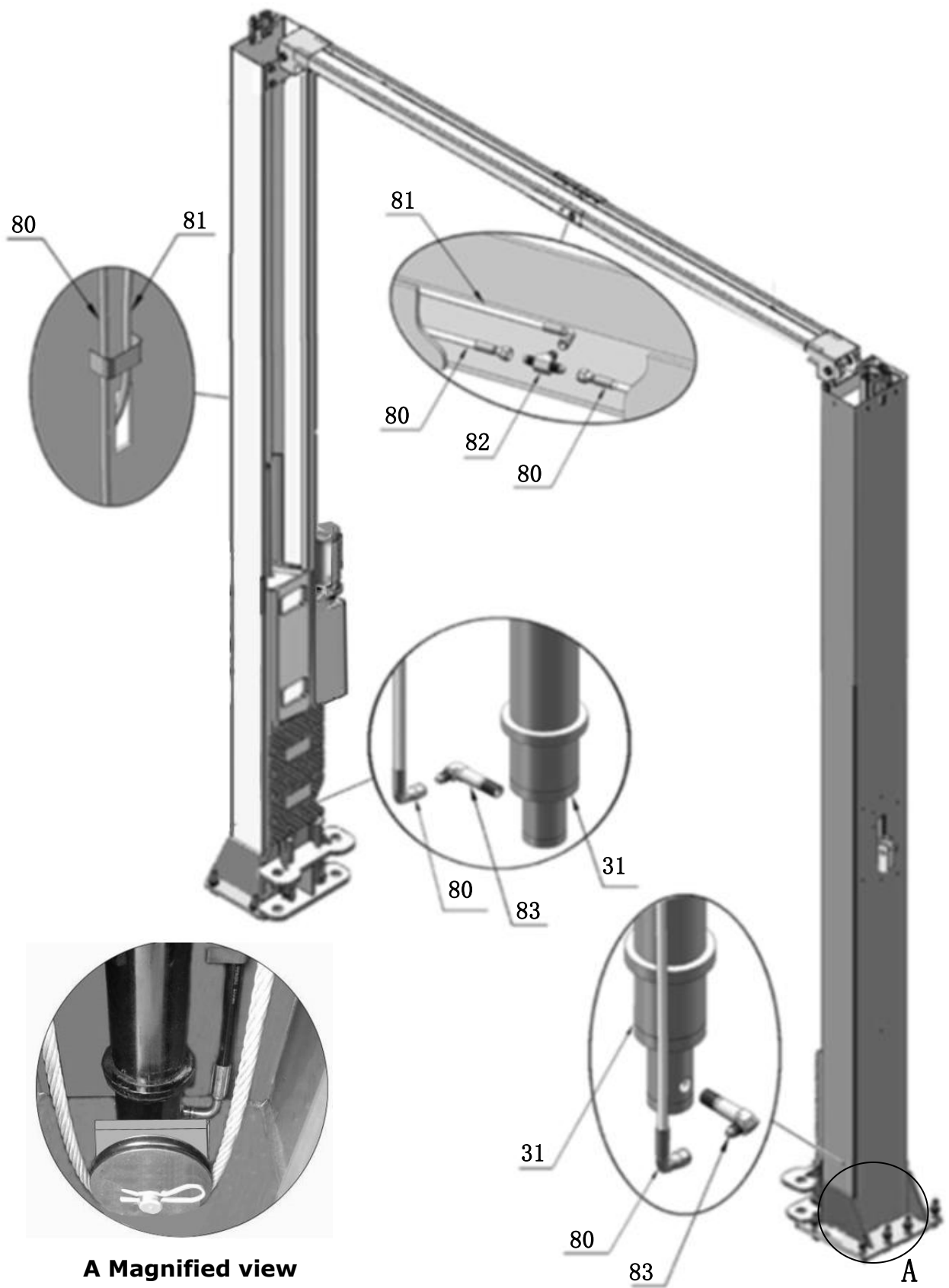

Fig.29

2. OHX-10H Oil hose Installation (See Fig. 30).

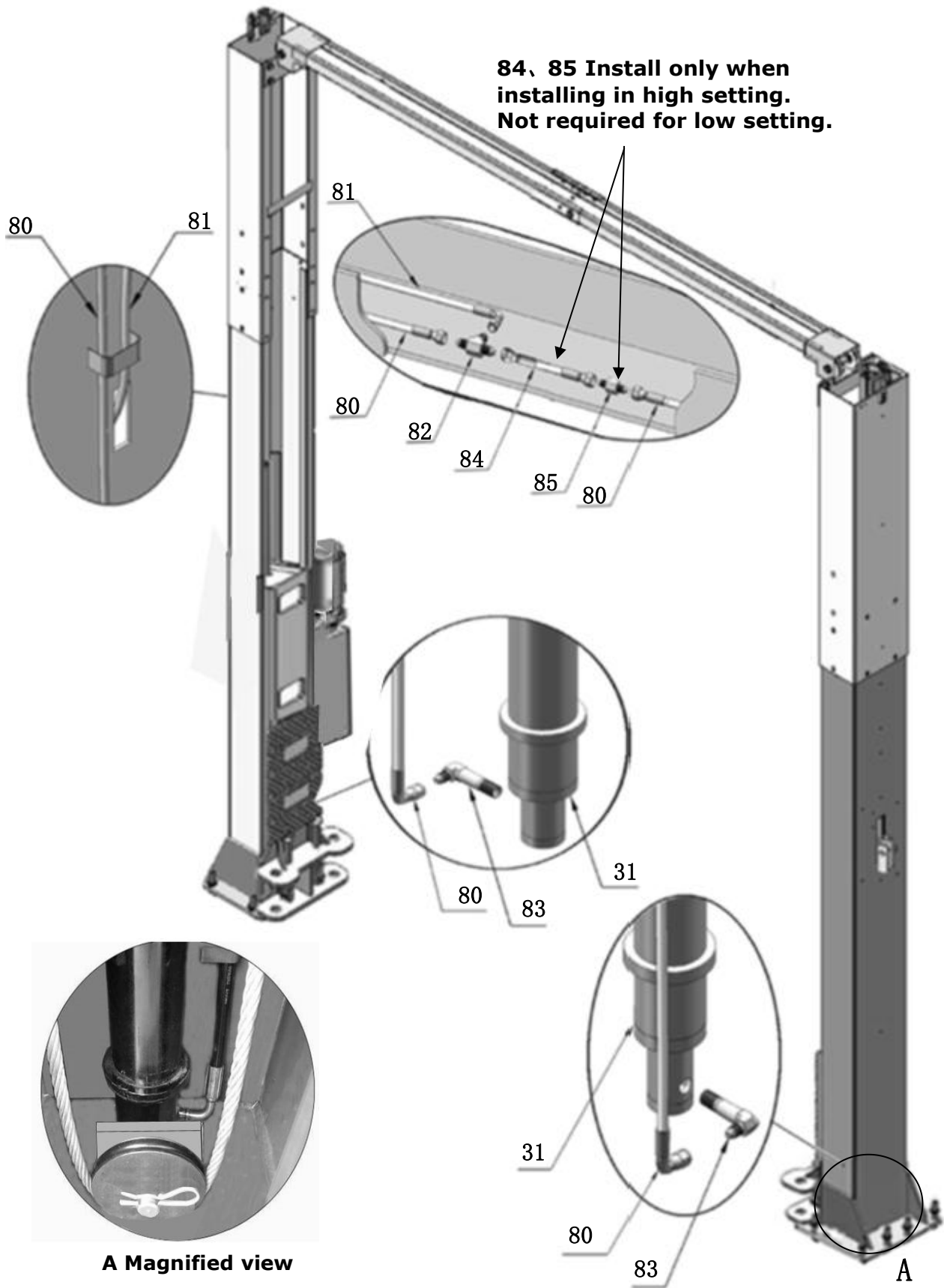

Fig.30

3. Follow these step to connect the oil hose of power unit.

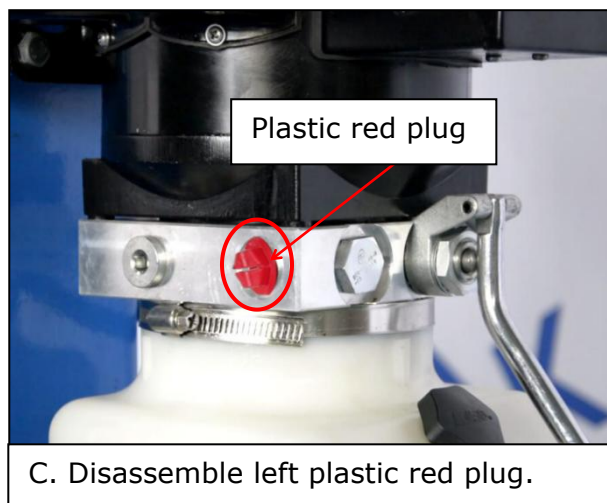
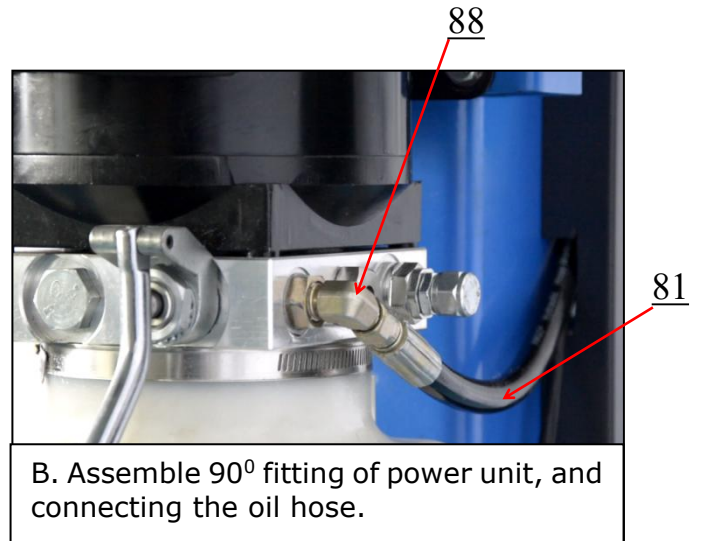
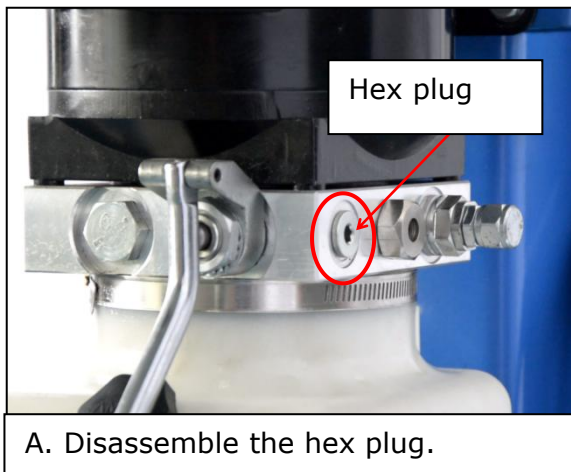
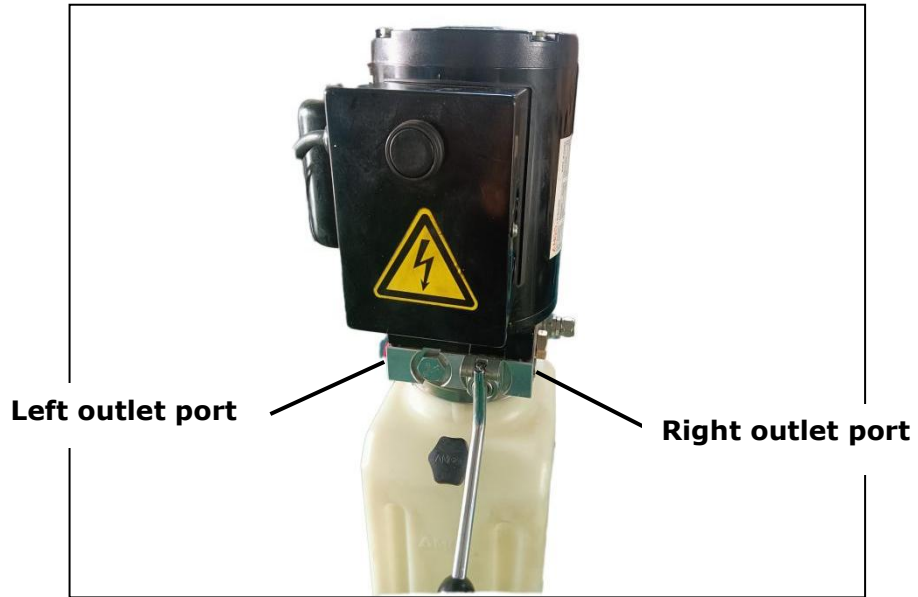
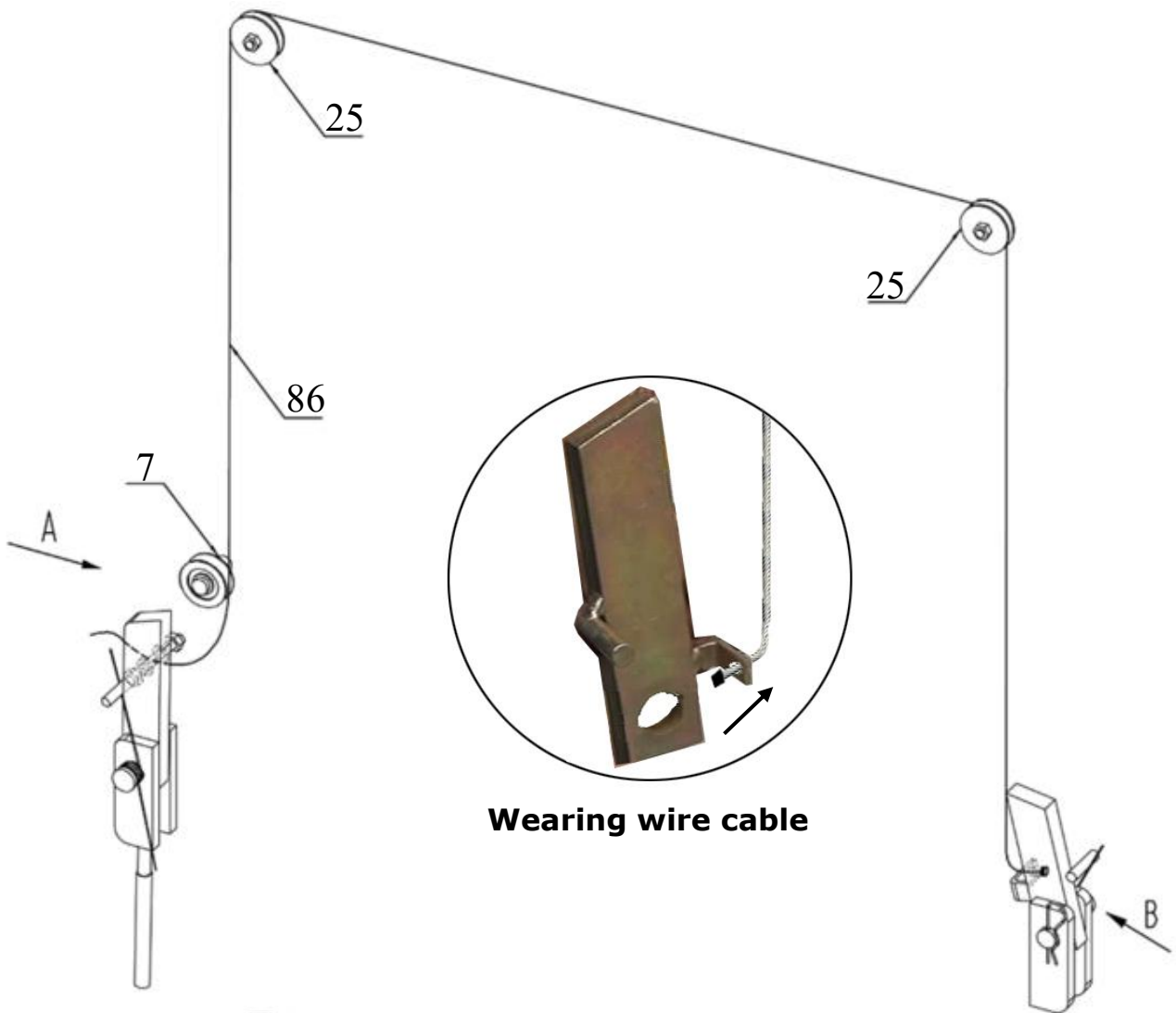

Fig.31

M. Install safety cable (See Fig. 32)



A side



B side

Fig.32

Note: Don't cross the oil hose and safety cable (See Fig. 33, 34 & 35).

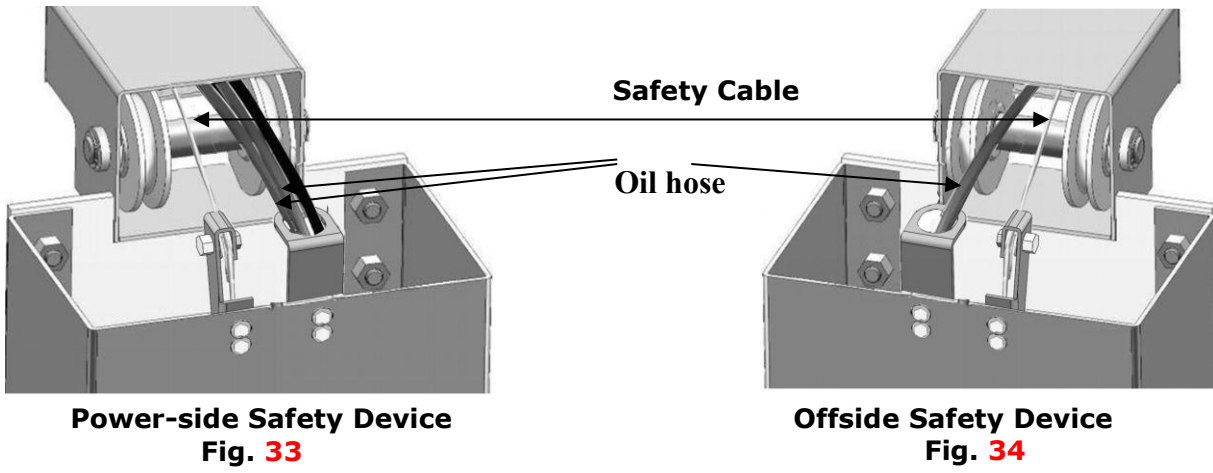

The safety cable cannot put inside cable clamp on top of overhead beam

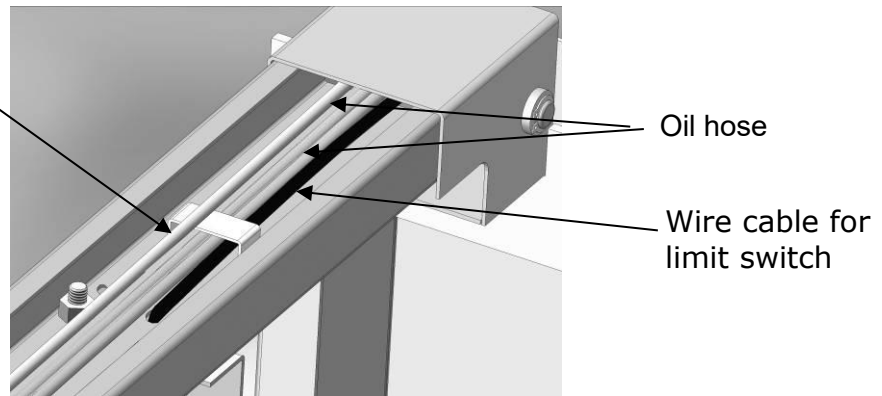

Fig.35

N. Install lifting arms and adjust the arm locks.

1. Install the lifting arms (See Fig. 36).
2. Lowering the carriages down to the lowest position, then use the 8# socket head wrench to loosen the socket bolt (See Fig. 37).

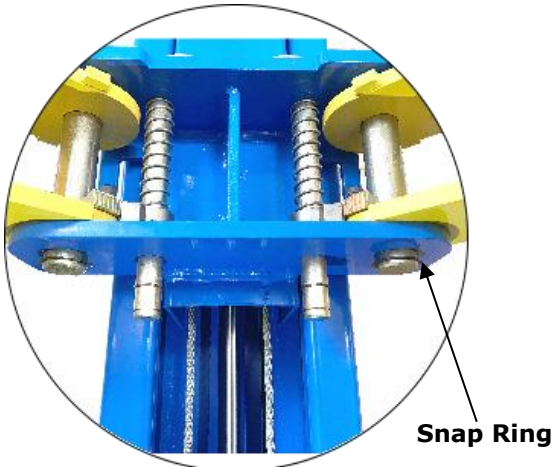

Fig. 36

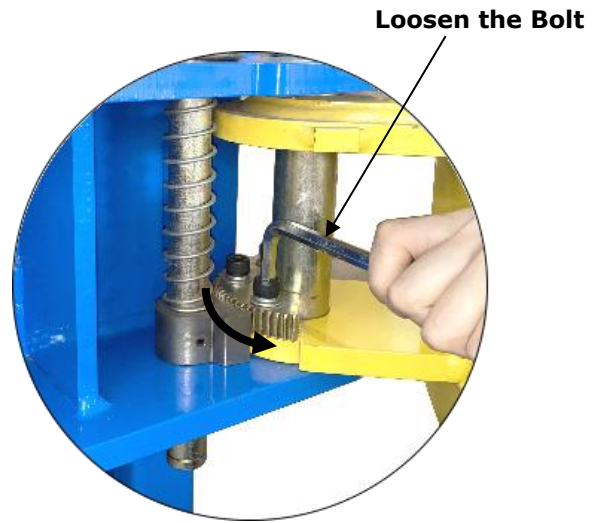

Fig. 37

Use the 8# Socket Head Wrench to loosen the Socket Bolt.

3. Adjust the arm lock as direction of arrow (See Fig. 38)

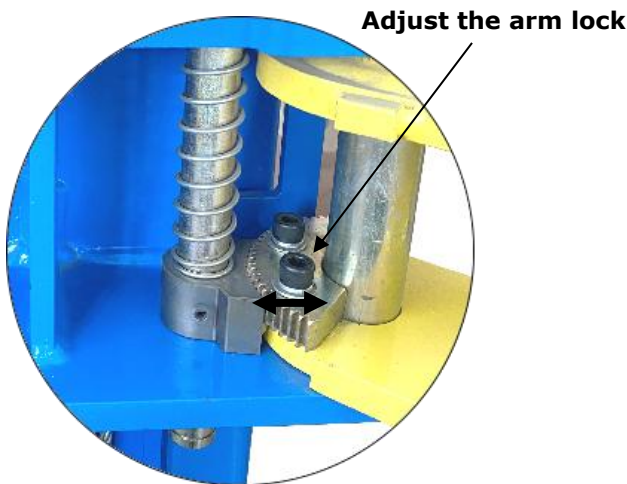

Fig. 38

Adjusting moon gear and arm lock to mesh.

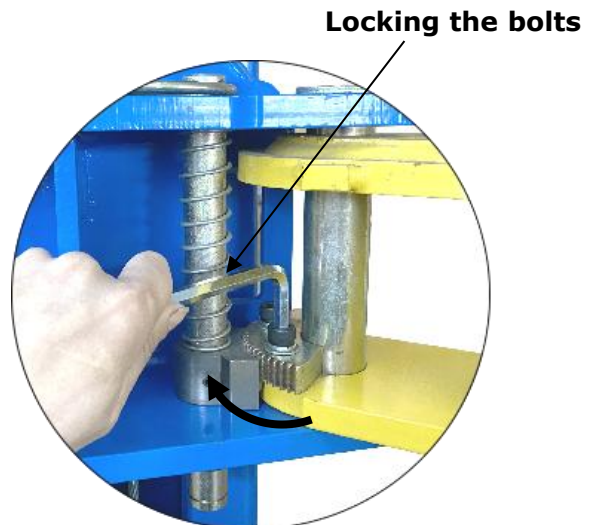

Fig. 39

Locking the bolts after the moon gear and arm lock engaged well.

4. Adjust moon gear and arm lock to make it to be meshed, then tighten the socket bolts of arm lock (See Fig. 39).

O. Tighten all the hydraulic fittings, and fill the reservoir with hydraulic oil.

Note: In consideration of Hydraulic Power Unit's durability and keep the equipment running in the perfect condition, please use Hydraulic Oil 46#.

P. Install electrical system

Connect the power source according to the nameplate of the motor.

Note: 1. Install the limit switch.

2. For the safety of operators, the lift must connect with the ground wire.

Single phase motor wiring

1. Circuit diagram (See Fig.40)

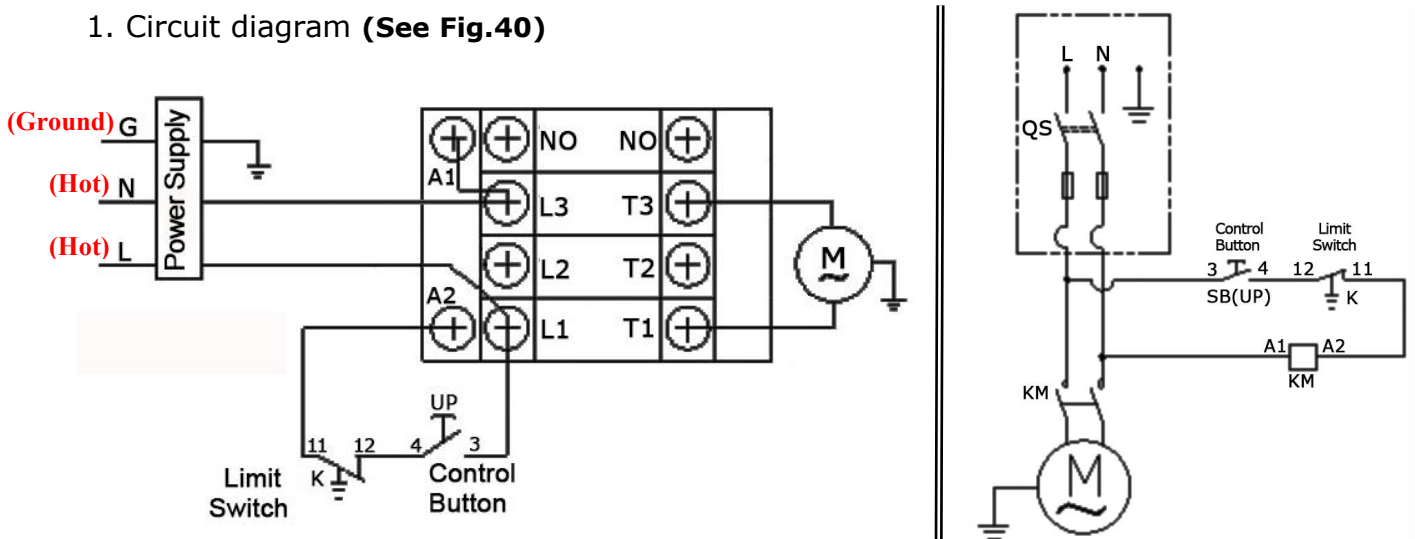

Fig. 40

2. Connection step

a. Connecting the two power supply wires to terminals of AC contactor marked L1, L3 respectively.

b. Connecting the limit switch: Removing the wire of connecting terminal 4# of control button and A2 of AC contactor firstly (See Fig. 42), then connecting wire 12# (brown wire) of limit switch with terminal 4# of control button and connecting wire 11# (blue wire) with terminals A2 of AC contactor respectively. Connecting the earth wire of limit switch to the earth wire terminal on the motor. (See Fig.43).

c. Terminals 3# of control button is connected with L1 terminals of AC contactor.

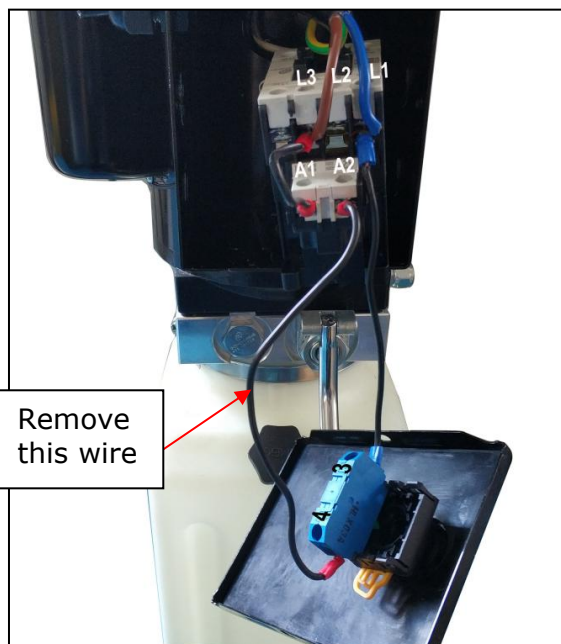

Fig. 41

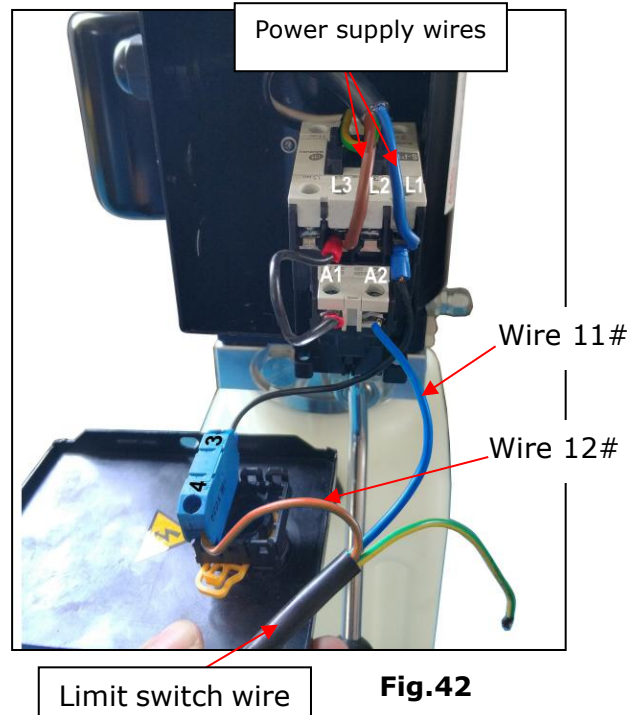

Fig.42

*** Optional width extension kits installation guide:
1.1. OHX-10: oil hose, top beam installation. (See Fig. 43)**

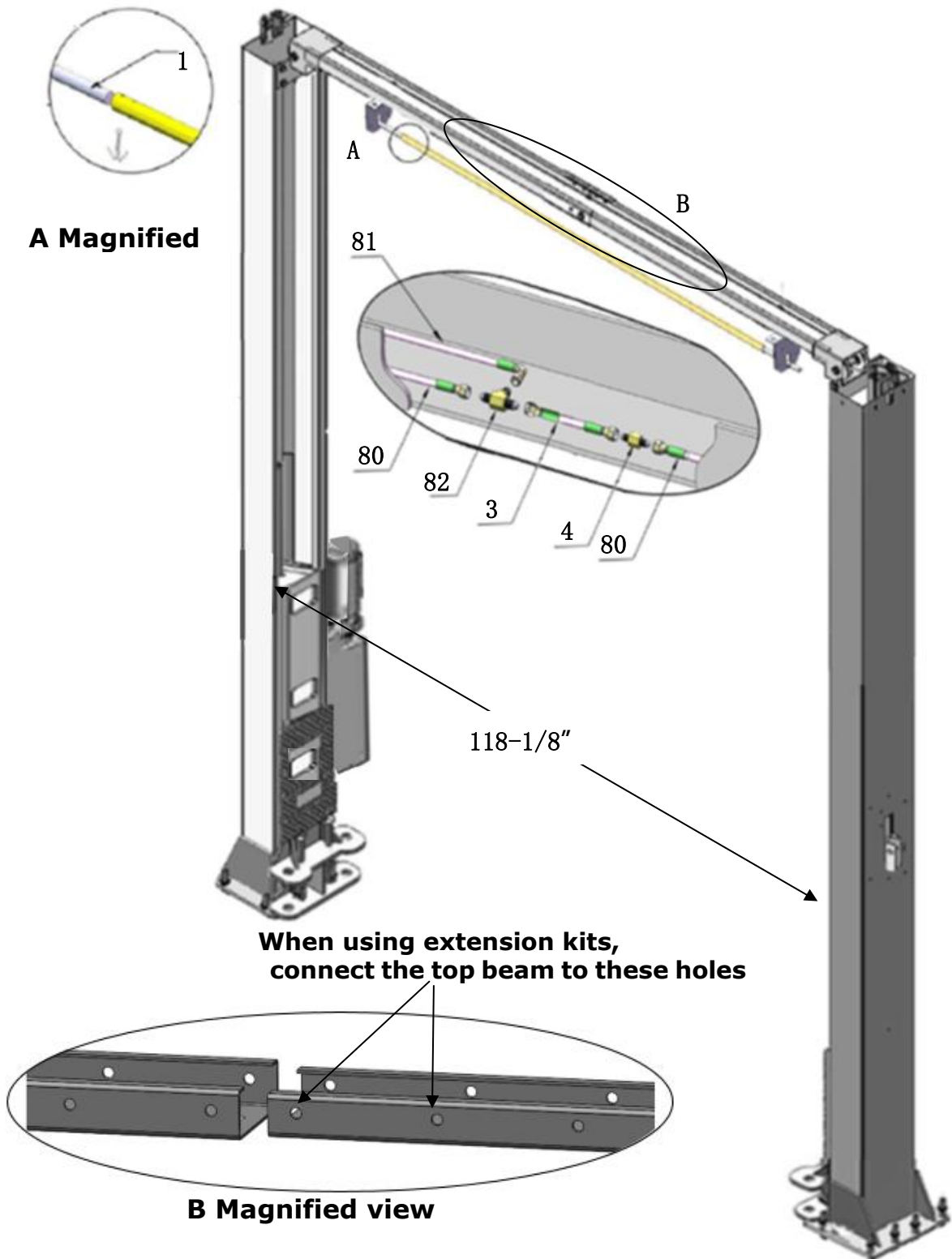

Fig.43

1.2. OHX-10: cable connection

Cables pass through the bottom of the carriages and be pulled out from the square hole of carriages, then screw the two cable nuts (See Fig. 44).

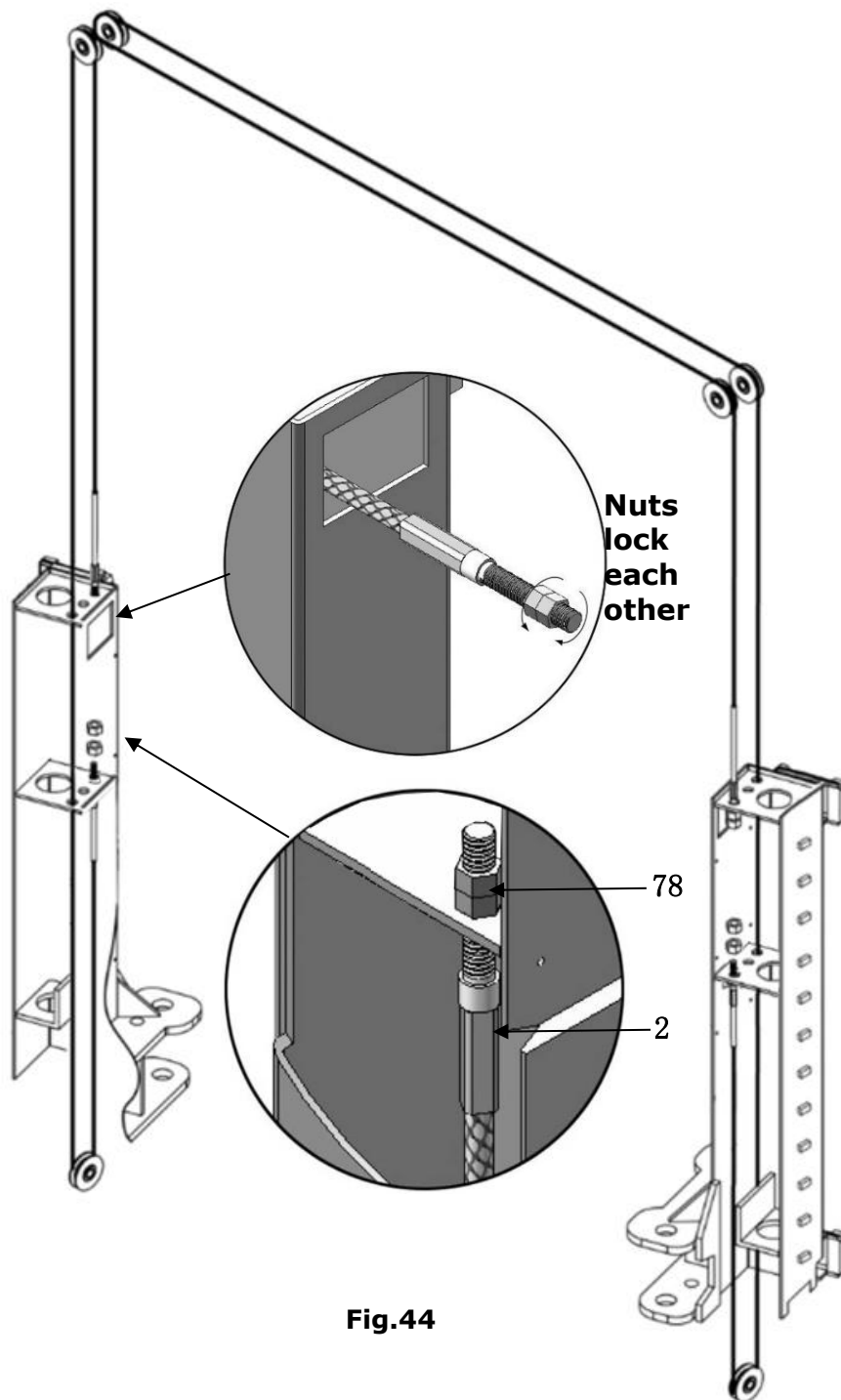
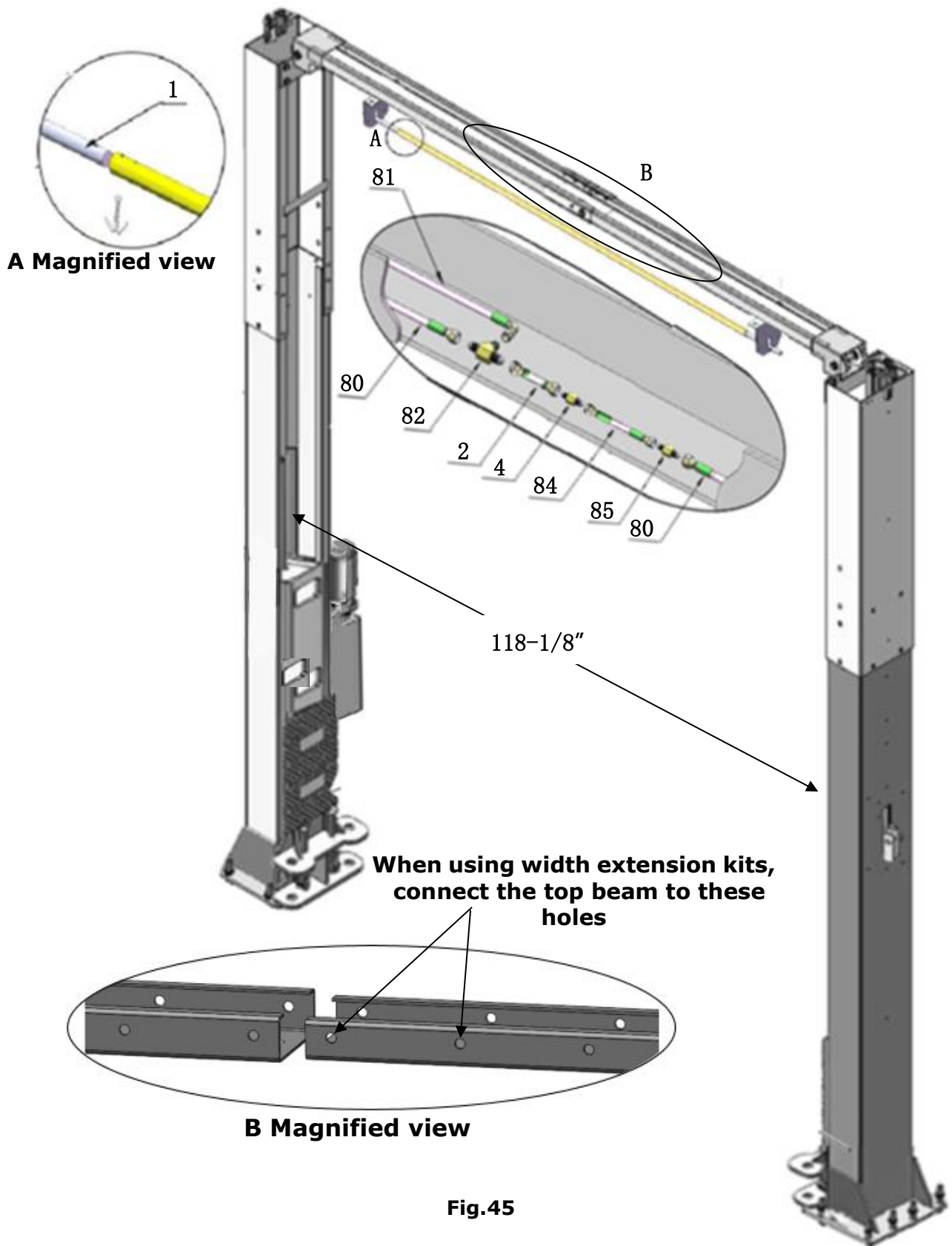

Fig.44

Optional parts list

Item	Part#	Description	OHX-10
			QTY.
1	1102562008	Control connecting pin assy.	2
2	1002561009	Cable assy. $\phi 9.52 \times 9790\text{mm}$	2
3	1002571011-01	Oil hose assy. 1/4"140mm	1
4	10620079	Straight fitting	1

2. OHX-10H: oil hose, top beam installation. (Fig.45)



2.1. OHX-10H: Cable connection for low setting. (Fig. 46)

Note: The cables should go inside the lifting carriage.

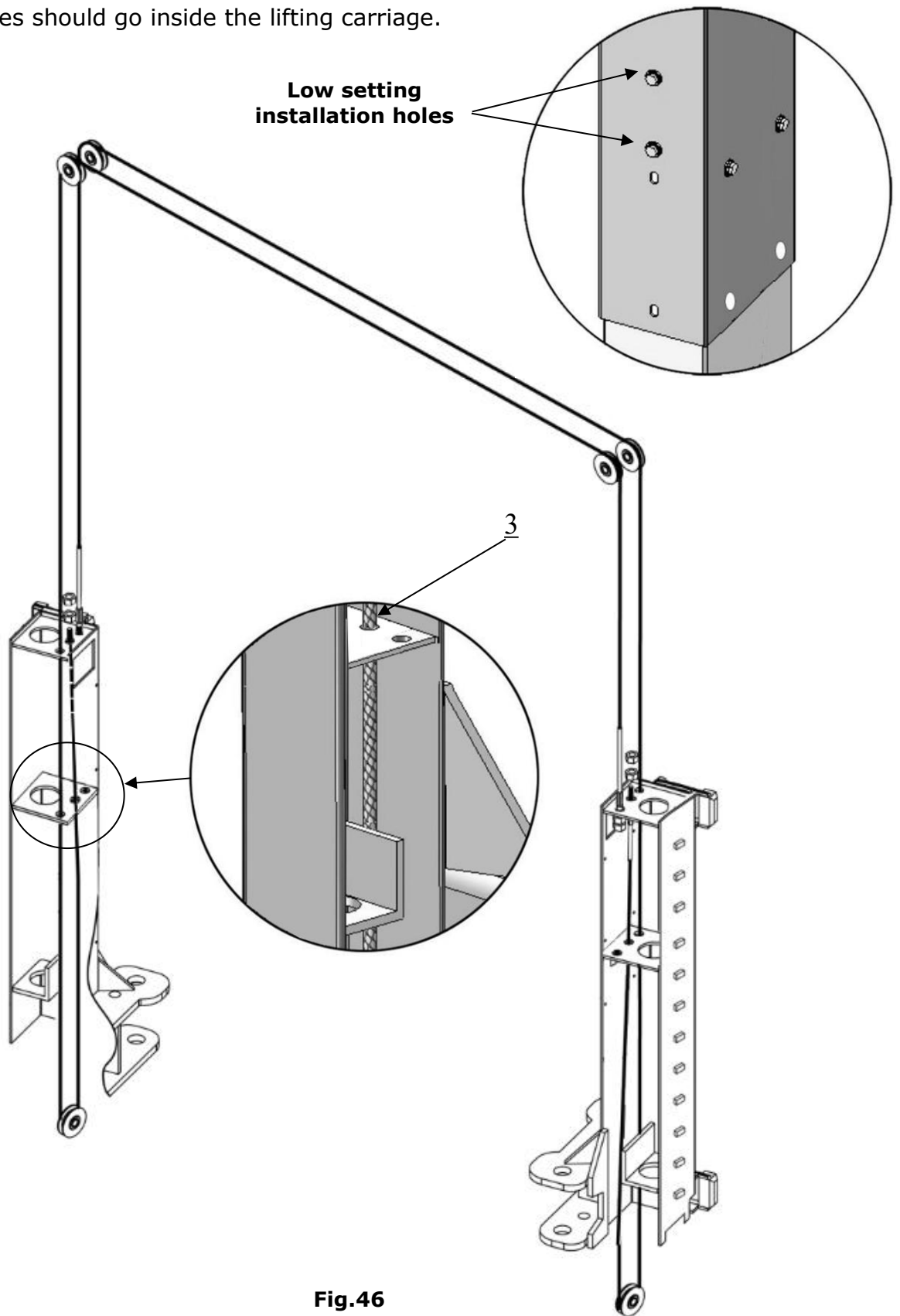

Fig.46

2. 2. OHX-10H: Cable connection for high setting (Fig. 47).

Cables pass through the bottom of the carriages and be pulled out from the square hole of carriages, then screw the two cable nuts.

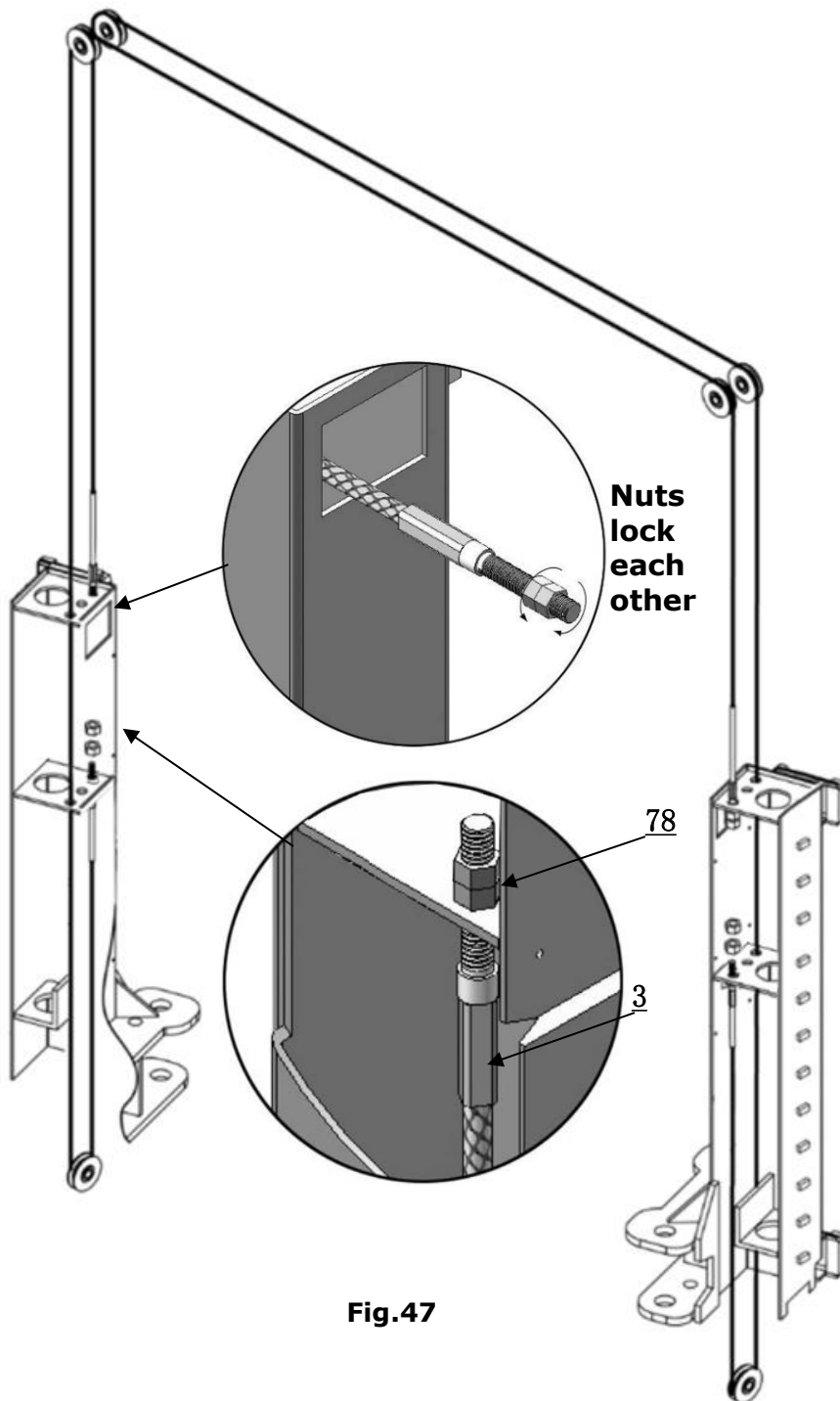

Fig.47

Optional parts list

Item	Part#	Description	OHX-10H
			QTY.
1	1102562008	Control connecting pin assy.	2
2	1002571011-01	Oil hose assy. 1/4" *140mm (2 straight)	1
3	1002571012	Cable φ9.52*11010mm	2
4	10620079	Straight fitting	1

IV. EXPLODED VIEW

OHX-10

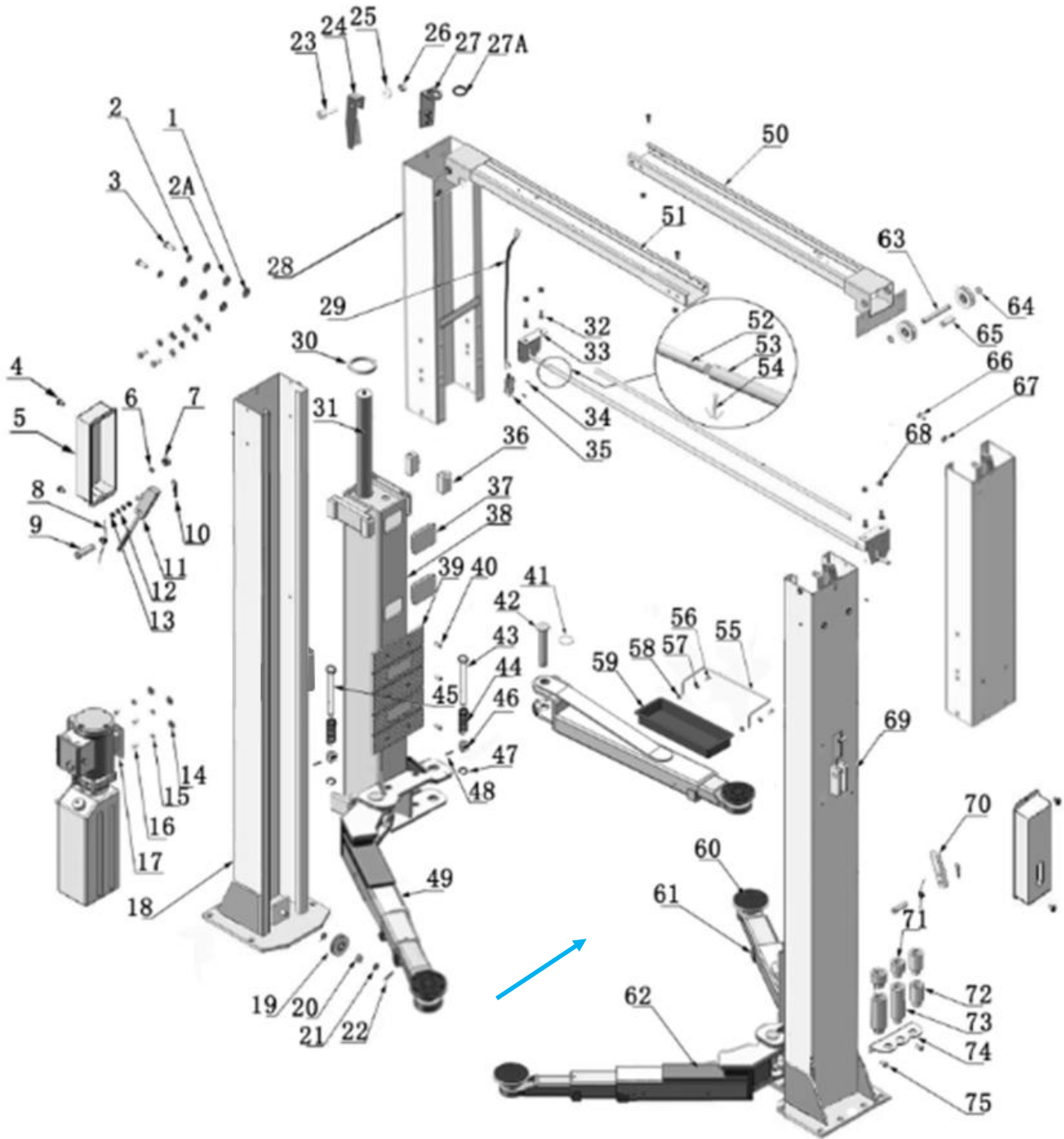

Fig. 48

OHX-10H

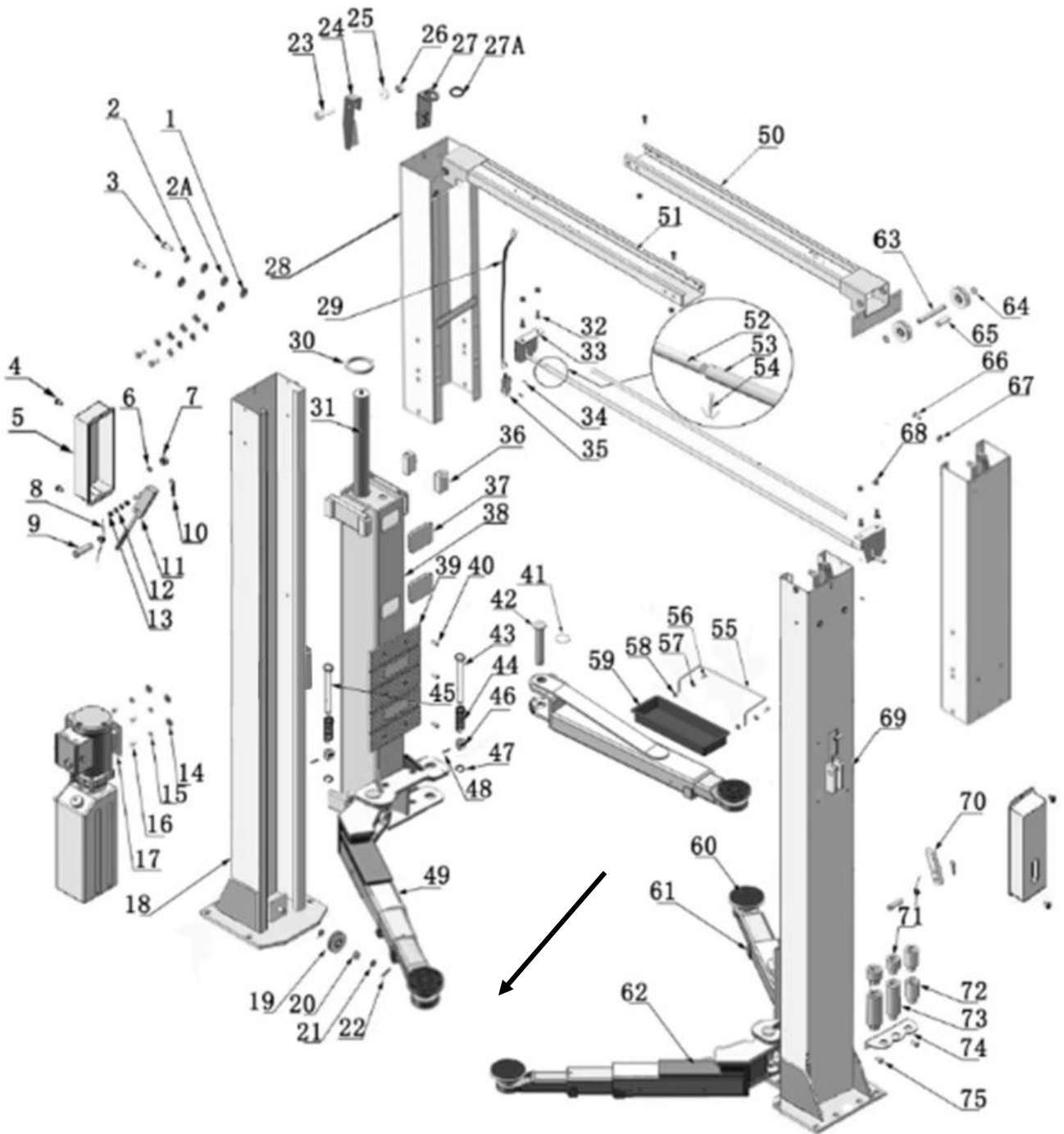

Fig. 49

PARTS LIST FOR OHX-10 and OHX-10H

Item	Part#	Description	QTY.	
			OHX-10	OHX-10H
1	10206017	Hex Bolt M10*20	0	20
2	10209039	φ10 Washer	12	32
2A	10209022	φ10 Washer	12	52
3	10209021	Hex Nut M10	0	20
4	10209009	Cap Head Bolt M6*8	4	4
5	10209008	Safety device protective cover	2	2
6	10209010	Snap ring (φ10)	1	1
7	10209049	Plastic pulley (Black)	1	1
8	10209007	Safety Spring	2	2
9	11206002	Safety lock pin	2	2
10	10209012	Elastic pin φ3.2	8	8
11	11209013	Power-side Safety Lock	1	1
12	10206006	φ12 Washer	2	2
13	10206023A	Hex Nut M12	2	2
14	10209005	Self-locking nut (M8)	8	8
15	10209004	Rubber ring φ8*20*3	4	4
16	10209003	Hex bolt M8*25	4	4
17	071101	Power unit	1	1
18	1102561001A	Power-side column	1	1
19	11206020	Pulley	6	6
20	10209057A	Bronzed bush for Pulley Φ*25.4*Φ 19.1*14.5	6	6
21	10209128	Washer φ20	8	8
22	10209012	Hair pin φ3.2	4	4
23	10209046	M10*35 Hex Bolt	2	2
24	1102561005	Pulley support bracket	2	2
25	10206009	Plastic pulley (white)	2	2
26	10209056	Self-locking Nut M10	2	2
27	1102561006	Oil hose support bracket	2	2
27A	1061K074	Protective coil	2	2
28	1102561003A	Outer column	0	2
29	1002561002	Cable	1	0
	1002571003		0	1
30	10209111	Cylinder guard coil	2	2
31	11217056	Cylinderφ50*1727	2	0
	1002576001	Cylinderφ50*1905	0	2
32	10206024	M12*25 Hex bolt	14	14
33	11206042	Control stick fixing block	2	2
34	10206011	Cap head bolt M5*12	2	2
35	10206013	Limit switch	1	1
36	10209015	Slider block	16	16
37	10209016	Carriage plastic cover	4	4
38	1102563000A	Carriage	2	2
39	10209018	Protection rubber	2	2
40	10209019	M6*16 Screw	12	12
41	10520023	Snap ring φ38	4	4
42	11217168	Lift arm pin	4	4
43	11217046A	Arm lock handle (Left)	2	2
44	10206050A	Spring	4	4

Item	Part#	Description	QTY.	
			OHX-10	OHX-10H
45	11217046	Arm lock handle (Right)	2	2
46	10217044-01	Arm lock	4	4
47	10206032	Snap ring φ25	4	4
48	10206036	Hair pin φ6*40	4	4
49	10279010	Right front arm assy.	1	1
50	1102562000B	Top beam 2	1	1
51	1102562000A	Top beam 1	1	1
52	11206025C	Control bar contacting pin	2	2
53	11206129	Limit switch control bar L=2400mm	1	1
54	10201005	Split Pin (φ4*50)	2	2
55	11206154	Rear guard	2	2
56	10201002	M8*16 Hex bolt	4	4
57	10209034	φ8 Lock Washer	4	4
58	10209033	φ8 Washer	4	4
59	10206156	Tool tray	2	2
60	10201046A	Rubber pad assy.	4	4
60A	10420138	Socket bolt M6*16	4	4
60B	10209134	Rubber Pad	4	4
60C	11680030C	Rubber pad pallet	4	4
61	10279011	Rear arm assy.	2	2
62	10279009	Left front arm assy.	1	1
63	11206021	Pulley pin	2	2
64	10206019	Snap ring φ19	4	4
65	11206022	Pulley shaft limit cap	2	2
66	10217013	M6*20 Hex bolt	8	8
67	10420018	M6 Self-locking Nut	8	8
68	10206023	M12 Self-locking Nut	18	18
69	1102561002A	Offside column	1	1
70	11211013	Offside safety device	1	1
71	11209051B	Stackable adaptor (1.5 ")	4	4
72	11209052B	Stackable adaptor (2.5 ")	4	4
73	11209053B	Stackable adaptor (5 ")	4	4
74	11209054A	Stackable adaptor bracket	2	2
75	10680003	M8*12 Hex bolt	4	4
76	10209059	Anchor bolt 3/4*5-1/2	12	12
77	10201090	Shim (1mm)	10	10
77	10620065	Shim (2mm)	10	10
78	10209066	M16 Hex Nut	4	4
79	1002561004	Cable assy. φ9.52*9640mm	2	0
	1002571005	Cable assy. φ9.52*10860mm	0	2
80	1002561005-01	Oil hose assy. 1/4*5115mm	2	0
80	1002571002-01	Oil hose assy. 1/4*5425mm	0	2
81	1002561001-01	Oil hose assy. 1/4*4160mm	1	0
81	1002571001-01	Oil hose assy. 1/4*4490mm	0	1
82	10211016	T fitting	1	1
83	10211017	90° fitting for cylinder	2	2
84	1002571009-01	Oil hose assy. 1/4*550mm	0	1
85	10620079	Straight fitting	0	1
86	1002561003	Wire cable assy. L=6980mm	1	0

Item	Part#	Description	QTY.	
			OHX-10	OHX-10H
86	1002571004	Wire cable assy. L=8225mm	0	1
87	1102561500	Parts box	1	0
87	1102571500		0	1
88	10209060	90° fitting for power unit	1	1

4.1 Rear arm (10279011) explosive view

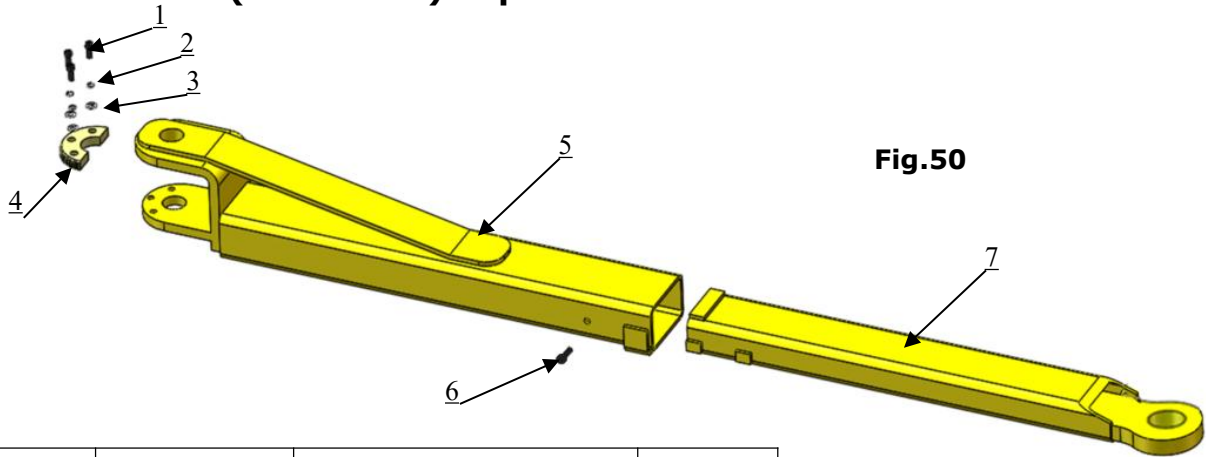

Item	Part#	Description	QTY.
1	10206048	Socket bolt M10*30	6
2	10209039	Lock washer φ10	6
3	10209022	Washer φ10	6
4	11206049	Moon gear	2
5	11206192	Outer rear arm assy.	2
6	10201149	screw M8*12	2
7	11206193	Inner rear arm assy.	2

4.2 Left front arm (10279009) explosive view

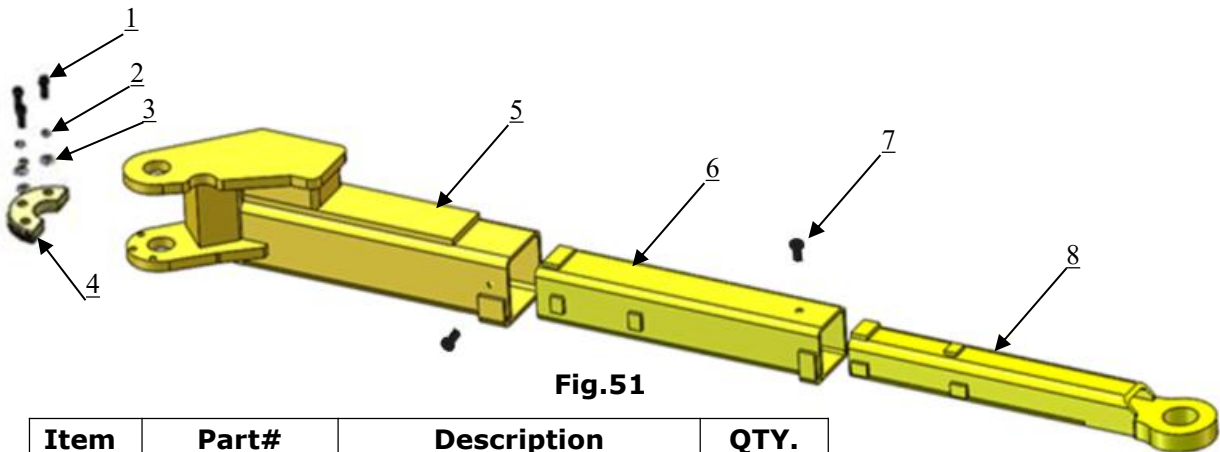

Item	Part#	Description	QTY.
1	10206048	Socket bolt M10*30	3
2	10209039	Lock Washer φ10	3
3	10209022	Washer φ10	3
4	11206049	Moon gear	1
5	11206183	Outer front left arm	1
6	11206189	Mid front left arm	1
7	10201149	Cap head bolt M8*12	2
8	11201049A	Inner front arm assy.	1

4.3 Right front arm (10279010) explosive view

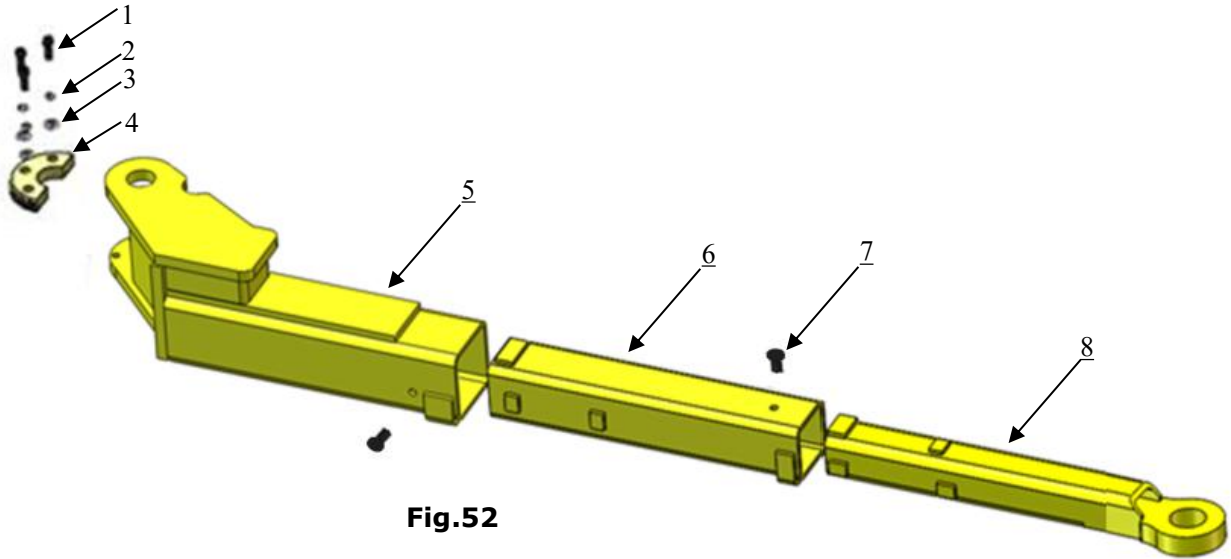

Fig.52

Item	Part#	Description	QTY.
1	10206048	Socket bolt M10*30	3
2	10209039	Lock Washer φ10	3
3	10209022	Washer φ10	3
4	11206049	Moon gear	1
5	11206182	Outer front right arm	1
6	11206189	Mid front arm	1
7	10201149	Cap head bolt M8*12	2
8	11201049A	Inner front arm	1

4.4 Cylinder (10209014/1002576001) explosive view

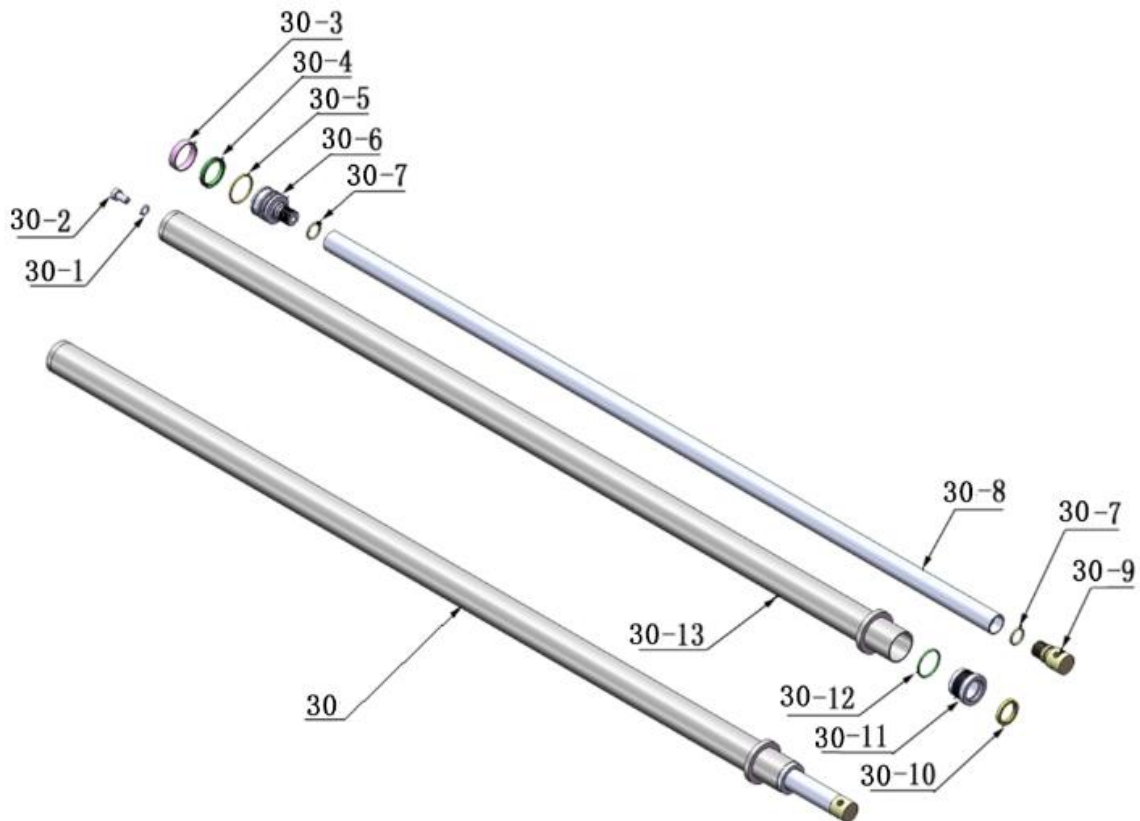

Fig.53

Part list for cylinder

Item	Part#	Description	QTY.
30-1	10209069	O-ring	2
30-2	10209070	Bleeding Plug	2
30-3	10209071	Support Ring	2
30-4	10209072	Y-ring OSI	2
30-5	10209073	O-ring	2
30-6	11209074	Piston	2
30-7	10209075	O-Ring	4
30-8	11209076	OHX-10 piston rod	2
	1102576002	OHX-10H piston rod	2
30-9	11209077	Piston Rod Fitting	2
30-10	10209078	Dust wing	2
30-11	11209079	cover	2
30-12	10209080	O ring	2
30-13	11209081	OHX-10 Cylinder weldment	2
	1102576003	OHX-10H Cylinder weldment	2

1. Power unit (071101) explosive view

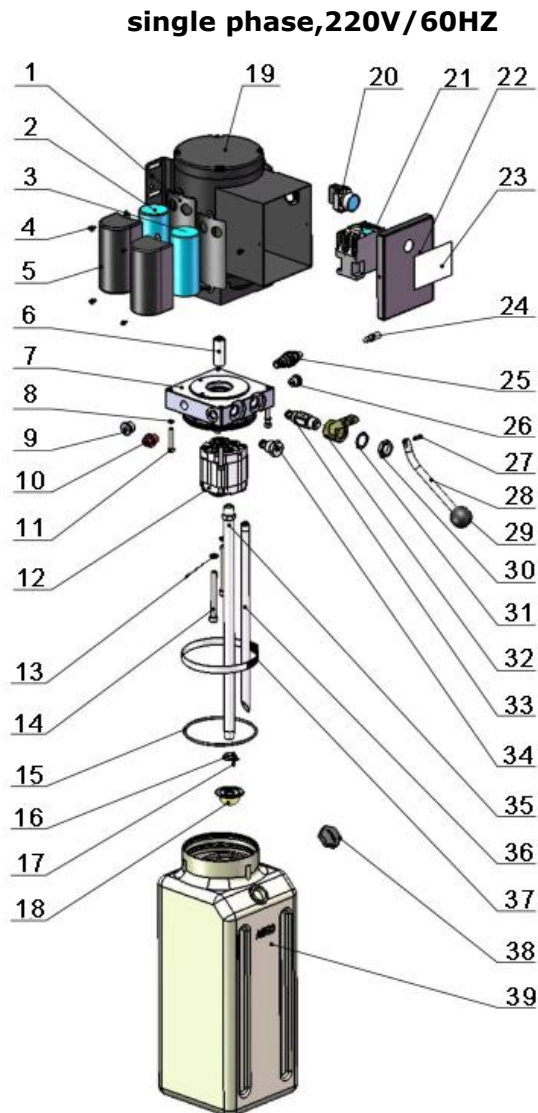

Fig. 54

Part list of power unit (220V/60HZ/single phase)

Item	Part#	Description	QTY.
1	81400180	Rubber pad	2
2	81400250	Starting capacitor	1
3	81400200	Running capacitor	1
4	10420148	Cap head nut with washer	4
5	81400066	Capacitor cover	2
6	81400363	Motor connecting shaft	1
7	80101013	Manifold block	1
8	10209149	Spring washer	4
9	81400276	Inner iron plug	1
10	81400259	Red rubber plug	1
11	85090142	Hex nut	4
12	81400280	Gear pump	1
13	10209034	washer	2
14	81400295	Hex nut	2
15	81400365	O-ring	1
16	10209152	Belt	1
17	85090167	Magnet	1
18	81400290	Filter net	1
19	81400413	Steel plate motor	1
20	10420070	Button switch	1
21	41030055	AC contractor	1
22	81400528	Motor wiring cover	1
23	71111216	AMGO plate	1
24	81400560	Throttle valve	1
25	81400266	Relief valve	1
26	81400284	Socket iron plug	1
27	10720118	Elastic pin	1
28	81400451	Release handle	1
29	10209020	Plastic ball for Release Handle	1
30	81400421	Release valve nut	1
31	81400422	Self-locking washer	1
32	81400447	Valve seat(Low)	1
33	81400567	Release valve	1
34	81400560	Check valve	1
35	81400288	Oil suction hose	1
36	81400289	Oil return hose	1
37	81400364	Clamp(stainless steel)	1
38	81400263	Oil tank cap	1
39	81400275	Oil tank	1

4.5 Illustration of hydraulic valve for hydraulic power unit

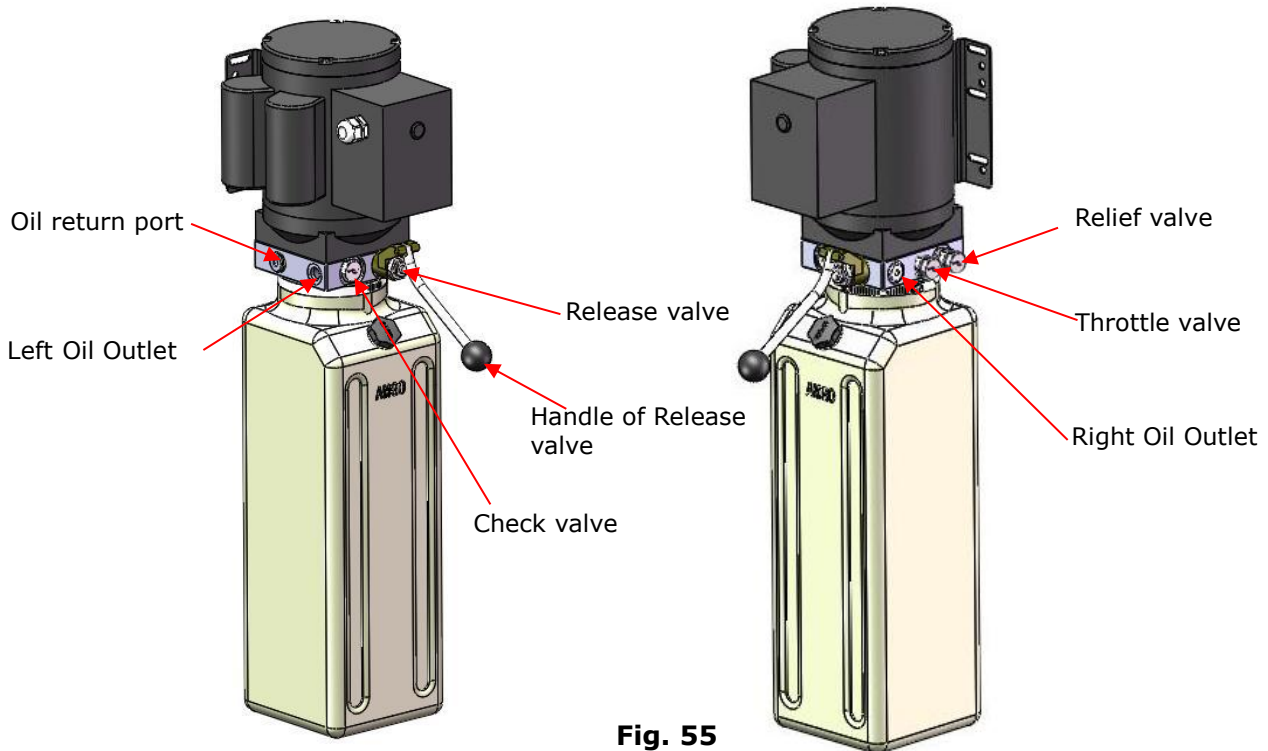

Fig. 55

V. TEST RUN

1. Adjustment of synchronous cable (See Fig. 56)

Use wrench to hold the cable fitting, meanwhile using ratchet spanner to tighten the cable nut until the two cables are in the same tension.

If the two vehicle carriages do not Synchronized when lifting and lowering, please screw and tighten the cable nut on the lower side carriage.

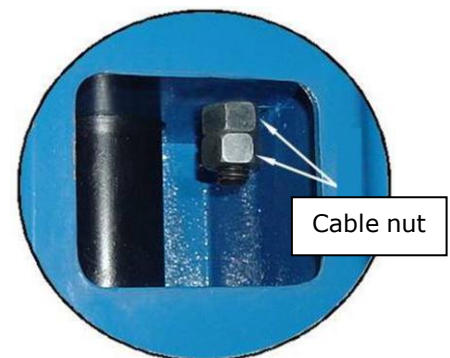

Fig. 56

2. Adjust safety cable

Rise the vehicle carriages and lock them at the same height, strain the safety cable and then release a little, and then tighten the safety cable nuts. Make sure the safety device can always lock the carriages properly.

At last, install the plastic cover of the safety device.

3. Bleeding air from oil cylinder (See Fig. 57)

Rise the vehicle carriages and lock them at the same height, strain the safety cable and then release a little, and then tighten the safety cable nuts. Make sure the safety device can always lock the carriages properly.

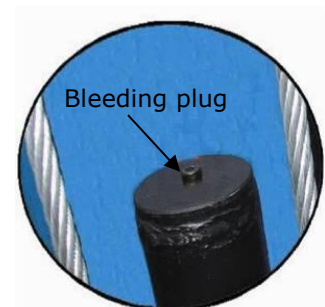
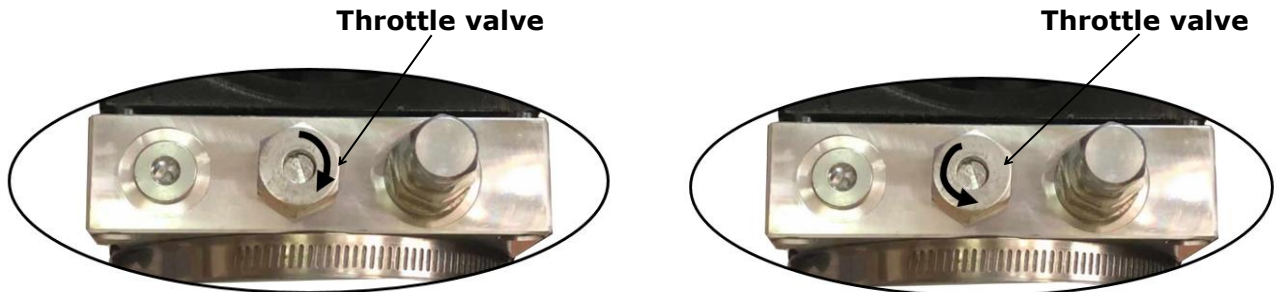

Fig. 57

At last, install the plastic cover of the safety device.

4. Adjust the lowering speed

You can adjust the lowering speed of the lift if needing: screw the throttle valve clockwise to decrease the lowering speed, or counterclockwise to increase the lowering speed.



Adjust clockwise, decrease lowering speed

Counterclockwise, increase lowering speed

Fig. 58

5. Test with loading

After finishing the above adjustment, test running the lift with loading. Run the lift in low position for several times first, make sure the lift can rise and lower synchronously, the Safety Device can lock and release synchronously. And then test run the lift to the top completely. If there are anything improper, repeat the above adjustment.

Hydraulic schematic

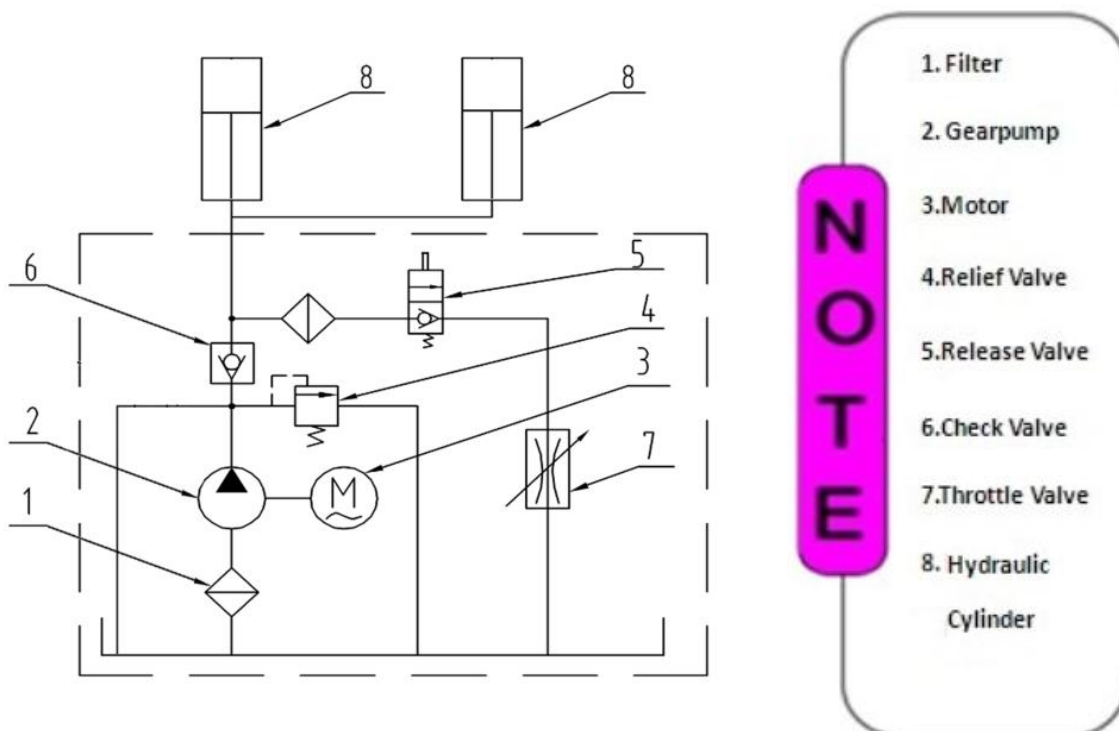

Fig.59

NOTE

VI. OPERATION INSTRUCTIONS

Please read the safety tips carefully before operating the lift

To lift vehicle

1. Keep clean of site near the lift;
2. Position lift arms to the lowest position;
3. To shortest lift arms;
4. Open lift arms;
5. Position vehicle between columns;
6. Move arms to the vehicle's lifting point;

Note: The four lift arms must contact the vehicle's lifting point at the same time where manufacturers recommended

7. Push button **UP** until the lift pads contact underside of vehicle totally. Recheck to make sure vehicle is secure;
8. Continue to raise the lift slowly to the desired working height, ensuring the balance of vehicle;
9. Push lowering handle to lower lift onto the nearest safety. The vehicle is ready to repair.

To lower vehicle

1. Be sure clear of around and under the lift, only leaving operator in lift area;
2. Push button **UP** to raise the vehicle slightly, and then release the safety device, lower vehicle by pushing lowering handle.
3. Open the arms and position them to the shortest length;
4. Drive away the vehicle.
5. Turn off the power.

VII.MAINTENANCE SCHEDULE

Monthly:

1. Re-torque the anchor bolts to 150 N.M;
2. Check all connectors, bolts and pins to insure proper mounting;
3. Lubricate cable with lubricant;
4. Make a visual inspection of all hydraulic hoses/lines for possible wear or leakage;
5. Check Safety device and make sure proper condition;
6. Lubricate all Rollers and Pins with 90wt. Gear oil or equivalent;

Note: All anchor bolts should take full torque. If any of the bolts does not function for any reason, DO NOT use the lift until the bolt has been replaced.

Every six months:

1. Make a visual inspection of all moving parts for possible wear, interference or damage.
2. Check and adjust as necessary, equalizer tension of the cables to insure level lifting.
3. Check columns for plumpness.
4. Check Rubber Pads and replace as necessary.
5. Check Safety device and make sure proper condition.

Oil cylinder maintenance:

In order to extend the service life of the oil cylinder, please operate according to the following requirements.

1. Recommend to use N46 anti-wear hydraulic oil.
2. The hydraulic oil of the lifts should be replaced regularly during using. Replace the hydraulic oil 3 months after the first installation, Replace the hydraulic oil once a year afterwards.
3. Make at least one full trip raising and lowering per day. For exhausting the air from the system, which could effectively avoid the corrosion of the cylinder and damage to the seals caused by presence of air or water in the system.
4. Protect the outer surface of the oil cylinder's piston rod from bumping and scratching, and timely clean up the debris on the oil cylinder dust-ring and the piston rod.

VIII. TROUBLE SHOOTING

TROUBLE	CAUSE	REMEDY
Motor does not run	<ol style="list-style-type: none"> 1. Button does not work 2. Wiring connections are not in good condition 3. Motor burned out 4. AC contactor burned out 	<ol style="list-style-type: none"> 1. Replace button 2. Repair all wiring connections 3. Repair or replace motor 4. Replace AC Contactor
Motor runs but the lift is not raised	<ol style="list-style-type: none"> 1. Motor runs in reverse rotation 2. Gear Pump out of operation 3. Release Valve in damage 4. Relief Valve or Check Valve in damage 5. Low oil level 	<ol style="list-style-type: none"> 1. Reverse two power wire 2. Repair or replace 3. Repair or replace 4. Repair or replace 5. Fill tank
Lift does not stay up	<ol style="list-style-type: none"> 1. Release Valve out of work 2. Relief Valve or Check Valve leakage 3. Cylinder or Fittings leaks 	Repair or replace
Lift raises slowly	<ol style="list-style-type: none"> 1. Oil line is jammed 2. Motor running on low voltage 3. Oil mixed with air 4. Gear Pump leaks 5. Overload lifting 	<ol style="list-style-type: none"> 1. Clean the oil line 2. Check Electrical System 3. Fill tank 4. Replace Pump 5. Check load
Lift cannot lower	<ol style="list-style-type: none"> 1. Safety device are in activated 2. Release Valve in damage 3. Safety cable broken 4. Oil system is jammed 	<ol style="list-style-type: none"> 1. Release the safeties 2. Repair or replace 3. Replace 4. Clean the oil system

IX. Lift disposal.

When the car lift cannot meet the requirements for normal use and needs to be disposed, it should follow local laws and regulations.



AMGO HYDRAULIC CORPORATION

1931 Joe Rogers Blvd, Manning, South Carolina, USA

Zip: 29102

Tel: (803) 505-6410

Fax: (803) 505-6410

Manual No.: 72228105

Revised date: 2022/05