

Installation And Service Manual

TWO POST LIFT

Model:OH-9

Cargo Claims

If there is any missing or damaged product during transportation, the buyer must notate on the shipping paperwork or refuse the shipment. NOTATE ALL DAMAGE OR REFUSE DAMAGED SHIPMENT!



DANGER

Read the entire contents of this manual before using this product. Failure to follow instructions and safety precautions could result in serious injury or even death. Make sure all other operators also read this manual. Keep this manual near the machine so that it can be seen by all users. By proceeding with installation and operation, you agree that you are fully understand the contents of this manual and take full responsibility for the use of the product.

CONTENTS

PROFILE	1
IMPORTANT SAFETY INSTRUCTIONS	3
I. PRODUCT FEATURES AND SPECIFICATIONS	5
II. INSTALLATION REQUIREMENT	7
III. INSTALLATION STEPS	10
IV. EXPLODED VIEW	33
V. TEST RUN	40
VI. OPERATION INSTRUCTIONS	42
VII. MAINTENANCE SCHEDULE	43
VIII. TROUBLE SHOOTING	45
IX. CAR LIFT SAFETY TIPS	46
X. LIFT DISPOSAL	46

Explanation of the safety warning symbols used in this manual

-  DANGER Risk of death or injury
-  WARNING Dangerous or unsafe practices that may result in death or injury
-  CAUTION Dangerous or unsafe practices that may result in personal injury, product damage or property damage
- ATTENTION Conditions that may result in damage to products or property

PROFILE

This instruction manual is specially prepared for you. Your new lift is the product of over a decade of continuous research, testing and development and is the most technologically advanced lift on the market today.

Please make sure to read through this manual before operating the lift.

Record the information on the nameplate label here:

Model No.: _____

Serial No.: _____

Manufacturer date: _____

WARRANTY

The warranty period for the steel structure part of new car lift is 5 years, hydraulic components, bronze bushings, sliders and plastic parts are under warranty for 3 years, and electrical components and sync cable, lock release cable warranty for 2 year. Rubber pads are without warranty. During the warranty period, the manufacturer will repair or replace the defective parts free of charge including shipping costs.

This warranty does not cover damage caused by normal wear and tear, improper use, damage in transit, or damage caused by lack of maintenance.

This warranty is unique and supersedes what is expressed and implied in all other warranties. The manufacturer shall not be liable for any particular, indirect or accidental damage resulting in breach of or delay in the execution of the warranty. The manufacturer reserves the right to design and improve the product and has no obligation to make notice of the changes in advance.

The product warranty based on the above clause is based on the model number and serial number of the equipment. This information must be provided in conjunction with all warranty information at the time of service and warranty.

SAFETY WARNING LABEL



Fig. 1

IMPORTANT SAFETY INSTRUCTIONS

In order to properly maintain your product and ensure operator safety, it is the responsibility of the product owner to read and follow these instructions!

1. Ensure product installation complies with all applicable local regulations and rules, such as Occupational Safety and Health Administration regulations and electrical codes.
2. Ensure that all operators are properly trained, know how to operate the unit safely, and are properly supervised.
3. Do not operate the product until you are sure all parts are in place and operating correctly.
4. Keep your hands and feet away from the machine. Keep hands and feet away from any moving parts. Keep your feet away from the lift as it descends to avoid pressing on pointed objects.
5. Keep the work area clean. A cluttered workspace can lead to injuries.
6. The machine is only approved for indoor installation and use. Outdoor installation is prohibited.
7. Only trained operators are allowed to handle the lift machine. All untrained persons must stay away from the workplace. Never allow untrained persons to handle or operate the machine.
8. Use the lift properly. Use the lift in the correct way.
9. Warning! Keep no one under the lift when lifting the car.
10. If the vehicle is at risk of falling, keep no one around the lift.
11. Before preparing to approach or service the vehicle, ensure that the safety device is in effect.
12. Dress appropriately when operating machines, and consider wearing non-slip steel-soled shoes for added safety..
13. Beware of electric shock. In order to protect the operator from electric shock, the lift in use must be grounded. Do not connect the green wire to the terminal. This is the ground wire.
14. Danger! The power supply used in this type of lift has high voltage. Please disconnect the power supply before any circuit repair. Unplug in case the power supply is accidentally switched on during maintenance.
15. Warning! There is a risk of explosion. There are parts in the equipment that produce arc light and spark. Do not be exposed to easy gas. This machine should not be placed

in the lounge or basement.

16. Maintain with care. Keep the machine clean for better and safer operation. Perform proper lubrication and maintenance procedures according to the manual. Keep handles or buttons clean, dry, and free of oil.
17. Stay alert. Use common sense to observe what you are doing and stay alert.
18. Check for damaged parts. Check for adjustments to moving parts, damage to parts, or anything that may affect their operation. Do not use the machine if the parts are damaged.
19. Do not remove relevant safety parts from the machine. Do not use a lift if it is damaged or missing.
20. Operate the lift only temperature from 41⁰F to 104⁰F (5⁰C to 40⁰C).

! This symbol indicates important safety instructions that, if not followed, could endanger life and property or cause serious personal injury. Please read and follow all instructions in this manual before operating the equipment.

In order to protect the safety of personnel and equipment, only trained and competent operators who are fully aware of the use procedures, potential hazards, and the scope of use of the equipment, are allowed to touch and use the equipment if they are . The equipment is not designed to be used alone, but is also not designed to lift other machines or transport personnel.

I. PRODUCT FEATURES AND SPECIFICATIONS

- Direct-drive design, minimizes the lift wear parts and breakdown ratio.
- Dual hydraulic cylinders are designed and manufactured according to USA standard, utilizing imported seals
- Self- lubricating UHMW Polyethylene sliders .
- Single-point lock release mechanism.
- Clear-floor design, provide unobstructed floor use.
- Overhead safety shut-off device prevents vehicle damage
- Super asymmetric arms are convenient for car door open.
- Adjustable heights accommodates varying ceiling heights
- Double screw rubber pads

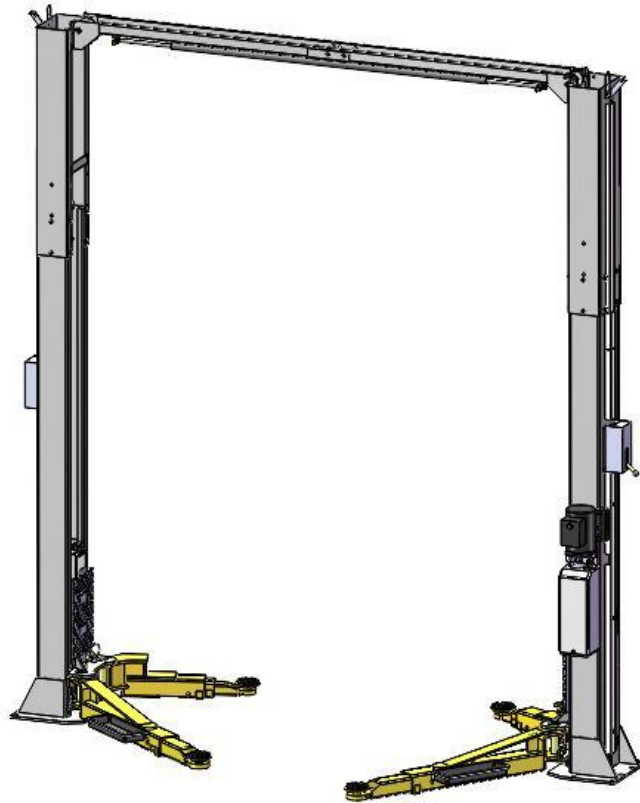

Fig. 2

Specifications and dimension figure

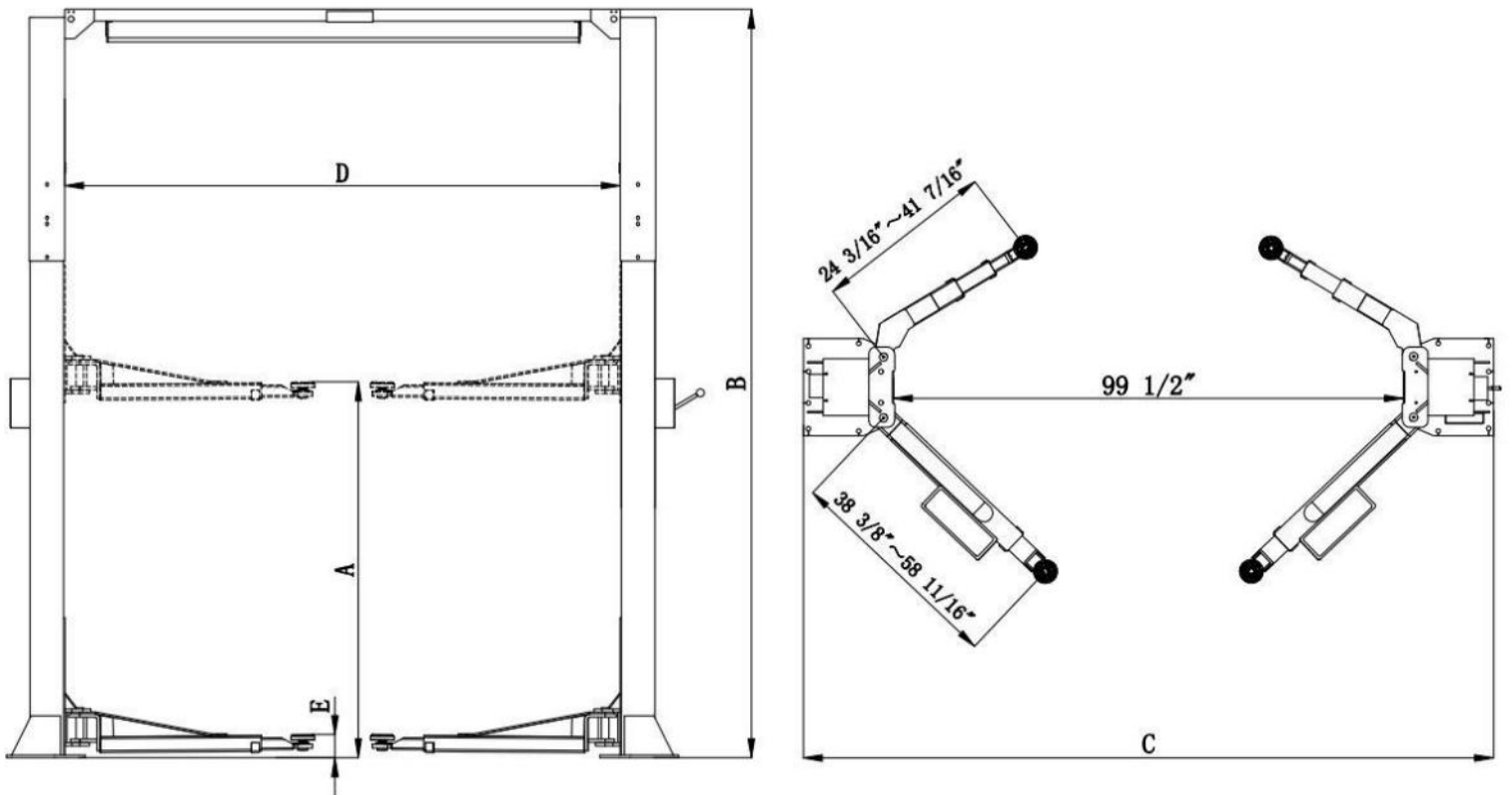

Fig.3

Model	Lifting Capacity	Lifting Time	A				B	C	D	E	Motor
			Max Lifting Height		Max safety lock height		Overall Height	Overall Width	Width Between Columns	Minimum Pad Height	
			Without extension adapter	Include extension adapter	Without extension adapter	Include extension adapter					
OH-9	9,000lbs	57S	71 7/16" ~ 73 3/8"	74 7/16" ~ 76 5/16"	69 5/8" ~ 71 1/2"	72 5/8" ~ 74 1/2"	143 1/8" 151"	135"	112 3/16"	3 9/16"	2.0HP

⚠ CAUTION When driving the vehicle, stay in the middle between the columns. If you hit any part of the lift, you could damage the car or lift.

II. INSTALLATION REQUIREMENT

A.TOOLS REQUIRED

↳ Rotary Hammer Drill ($\Phi 19$)



↳ Hammer



↳ Level Bar



↳ Adjustable Spanner (12")



↳ Wrench set: (10#, 13#, 14#, 15#, 17#, 19#, 24#, 27#)



↳ Ratchet Spanner With Socket (28#)



↳ Carpenter's Chalk



↳ Screw Sets



↳ Tape Measure (7.5m)



↳ Pliers



↳ Lock Wrench



↳ Socket Head Wrench (3#, 5#, 8#)



Fig.4

B. Equipment storage and installation requirements.

- 1 . Store the equipment in a dry, non-moldy, non-flammable environment.
- 2 . The lift is only approved for indoor installation and use, and outdoor installation is prohibited.
- 3 . When installing the device, take safety precautions according to the instructions to avoid device damage.
- 4 . Do not install the device outdoors if the installation area is not protected.
- 5 . During installation, all parts should be fastened to ensure the stability and smooth operation of the machine.
- 6 . After installation, the whole machine should be checked to make sure that every component is working properly.

C. The equipment should be unloaded and transferred by forklift. (See Fig.5)



Fig. 5

D. SPECIFICATIONS OF CONCRETE (See Fig. 6)

Specifications of concrete must be adhered to the specification as following.

Failure to do so may result in lift and/or vehicle falling.

1. Concrete must be thickness 4 inches minimum and without reinforcing steel bars, and must be dried completely before lift installation.
2. Concrete must be in good condition and must be of test strength 3000psi minimum. Solidify at least 15 days.
3. Floors must be level and contain no cracks or holes.
4. Do not install the lift on asphalt or any surface other than concrete.

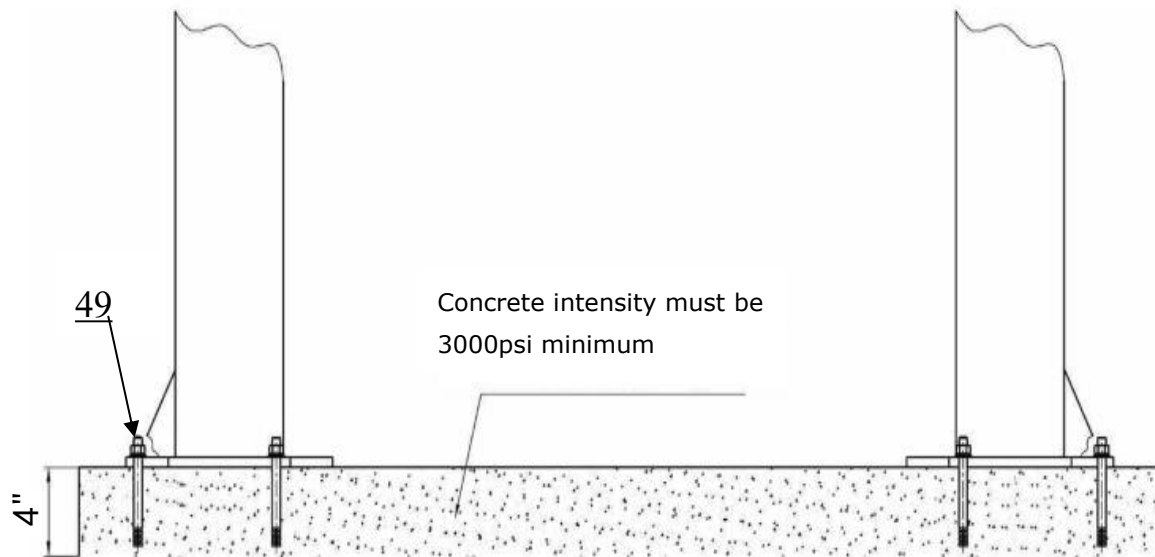

Fig.6

E. POWER SUPPLY

1. You are required to use a licensed and qualified electrician for the installation process.
2. The power supply capacity must be more than 3.0HP, with a cord larger than 12AWG, and must be properly grounded.

⚠ DANGER All electrical wiring must be performed by a licensed and certified electrician. Attempting to connect the circuit without proper certification may result in damage to the lift or electrocution, resulting in serious injury or death.

III. INSTALLATION STEPS

A. Location of installation

1. Installation space: Ensure there is enough space for the lift. Accurately measure the front, back, side and top mounting dimensions and refer to the below figure data(See Fig. 7).
2. Overhead obstacle: Check for overhead obstacles, such as building supports, heaters, lights, wires, and low ceilings, etc..
3. Installation: The lift is only approved for indoor installation and use, and outdoor installation is prohibited.
4. Floor: Install lift only on flat concrete floor. Do not install on asphalt or any other surface.

Ceiling height $\geq 151"$, can be both low setting/high setting;
Ceiling height between 143"-151", only available low setting;
Ceiling height $< 143"$ not available this model.

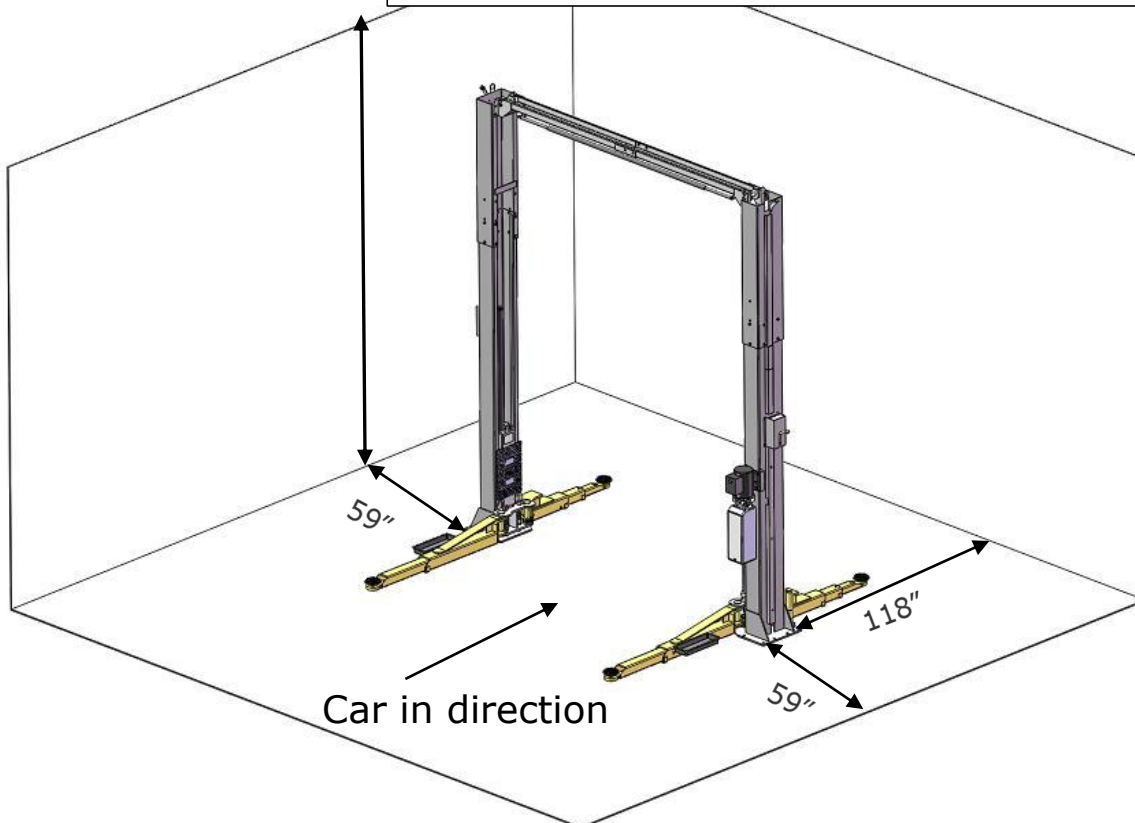
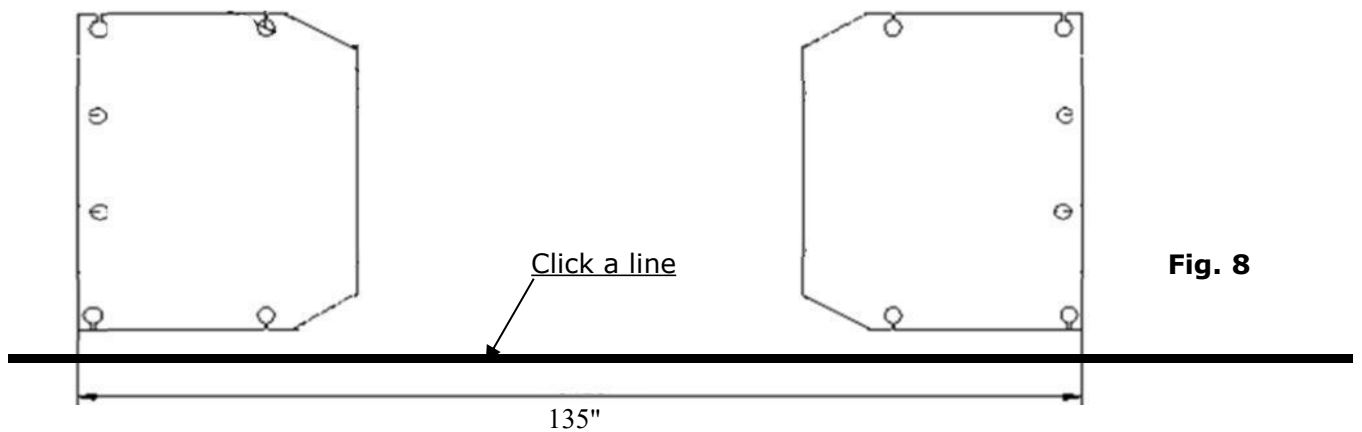

Fig. 7

⚠ CAUTION Installing the lift on a surface with slopes more than 3° could lead to injury or even death. This lift is designed for installation on a flat and level surface only. (Defined as no more than 10mm difference over the installation area). If the floor cannot be leveled, consider changing installation locations.

B. Use a carpenter's chalk line to establish installation layout of base-plate (See Fig.8).



C. Check the parts before assembly.

1. Packaged lift and hydraulic power unit (See Fig. 9).



2. Move aside the lift with fork lift or hoist, open the package, move aside the arms and parts box, and check the parts according to the shipment list. (See Fig. 12)

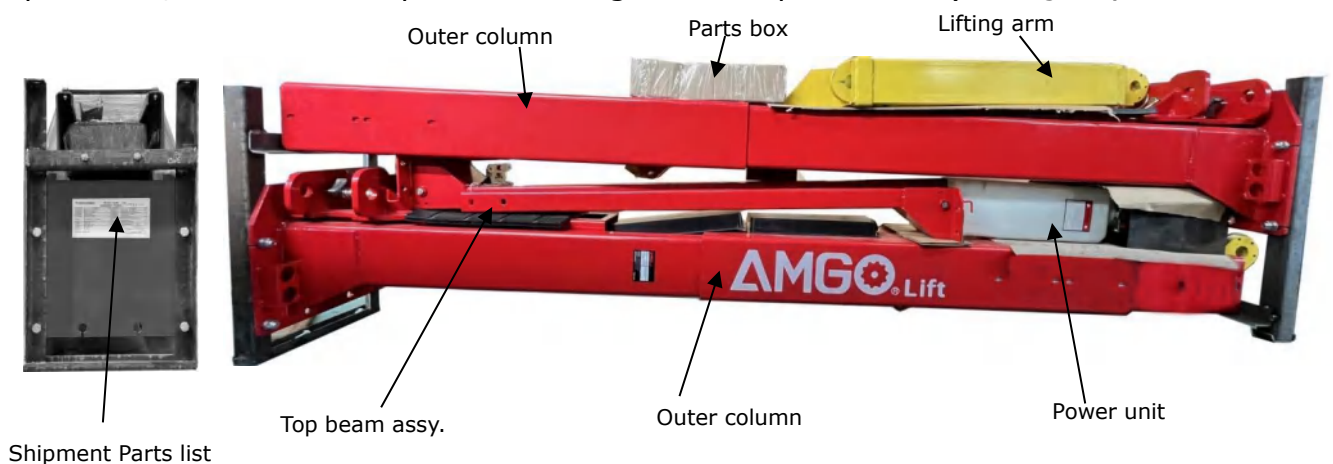
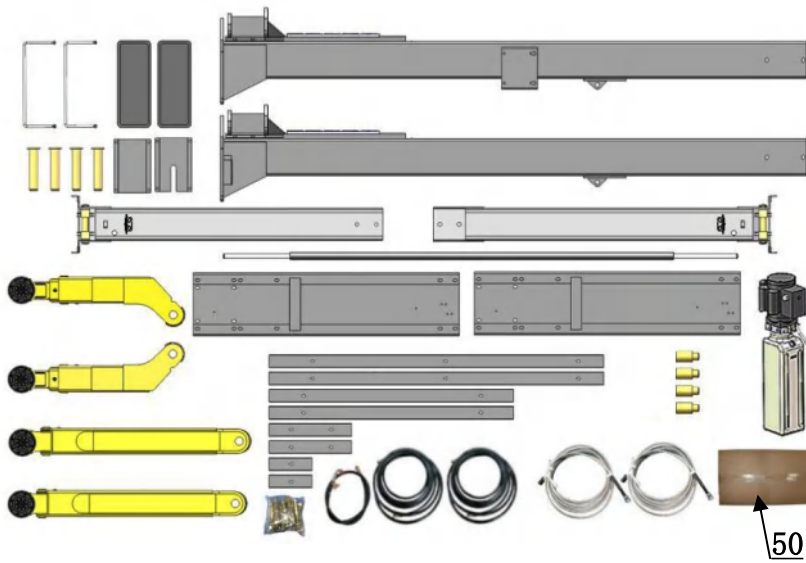

Fig. 10

3. Loosen the upper bolts of the package bracket, remove upper outer column, take out the parts inside the inner column, remove the upper inner column with a forklift or manually, then remove the package bracket.

4. Move aside the parts and check the parts according to the parts list. (See Fig. 11 & 12)



Shipment list
Fig. 11



Parts box (50)
Fig. 12

5. Check the parts of the parts bag 1 & 2 according to parts bag list (See Fig. 13).



Parts bag (1)



Parts bag (2)



Fig. 13

D. Install parts of outer column. (See Fig. 14).

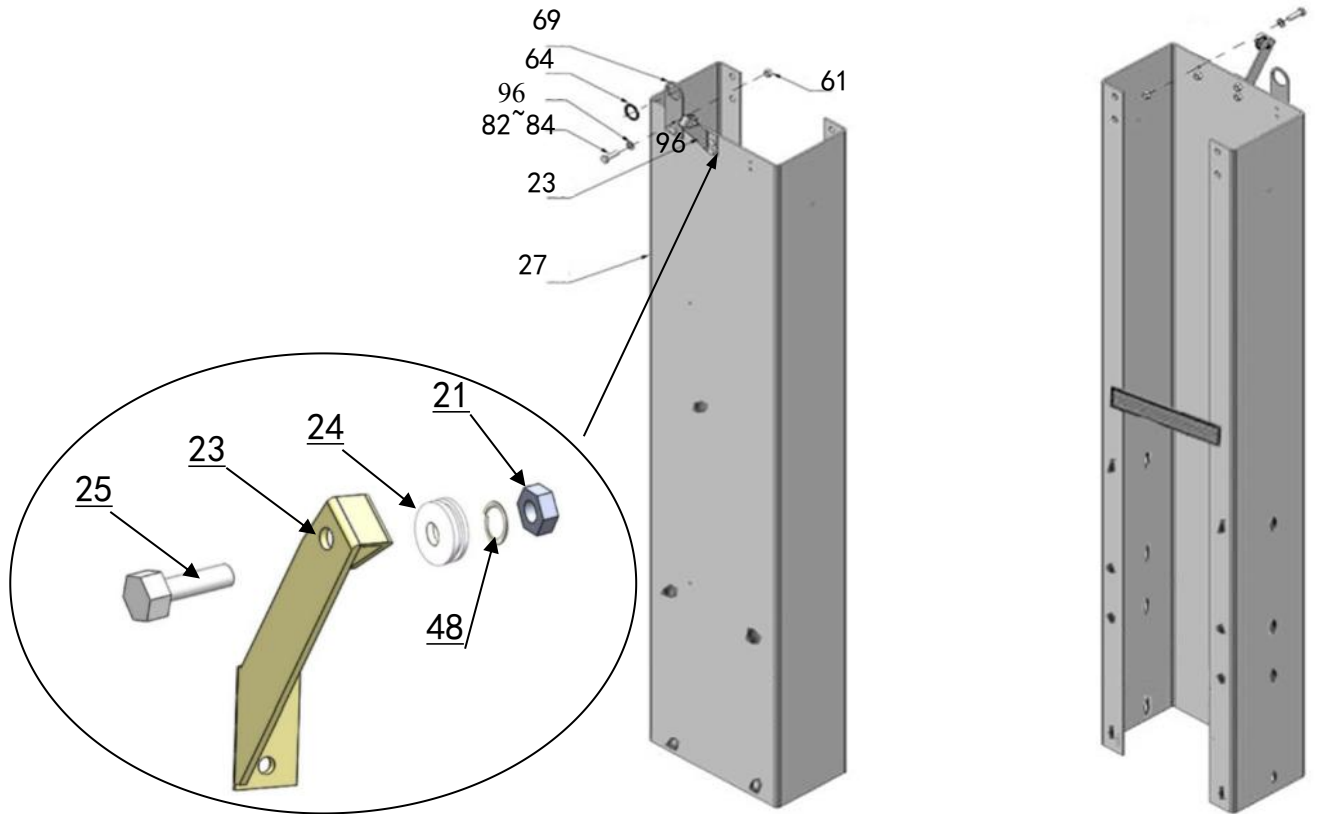

Fig. 14

E. Lay down two inner columns parallel on the installation site , position the power side column according to the actual installation site. Usually, it is suggested to install power side column on the front-right side from which vehicles are driven to the lift.

This lift is designed with 2-section columns, the height is adjustable according to the ceiling height, so connection positions of the inner column and outer column would be different.

1. OH-9 requirement:

- Ceiling height over 151-1/2", can be both low setting/high setting;
- Ceiling height between 143-3/4"-151-1/2", only available low setting;
- Ceiling height less than 143-3/4" not available this model.

Note:

- a. for high setting, connect the lower hole of the outer columns (see Fig.15).
- b. for low setting, connect the upper hole of the outer columns (see Fig.16).

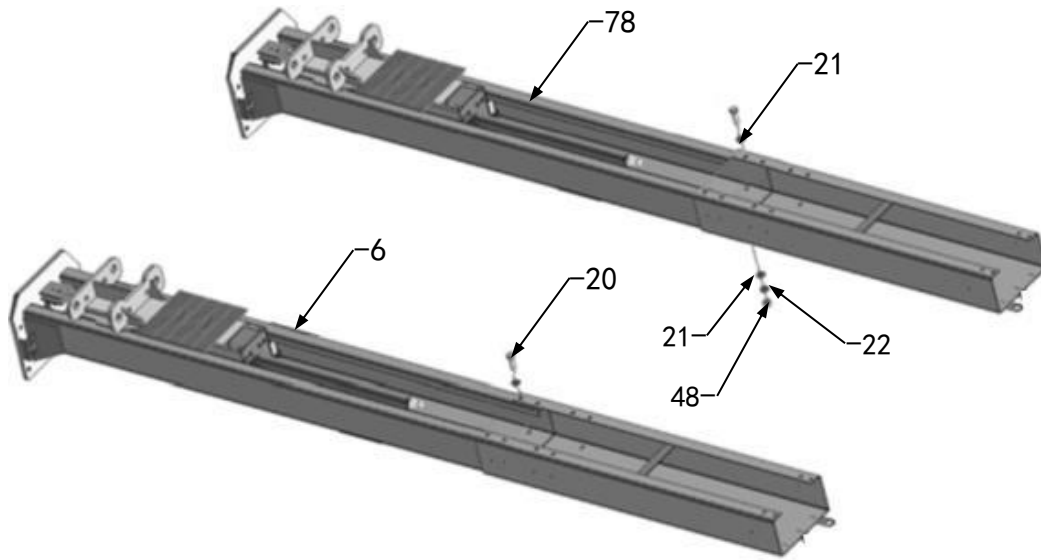

**High setting
Fig.15**

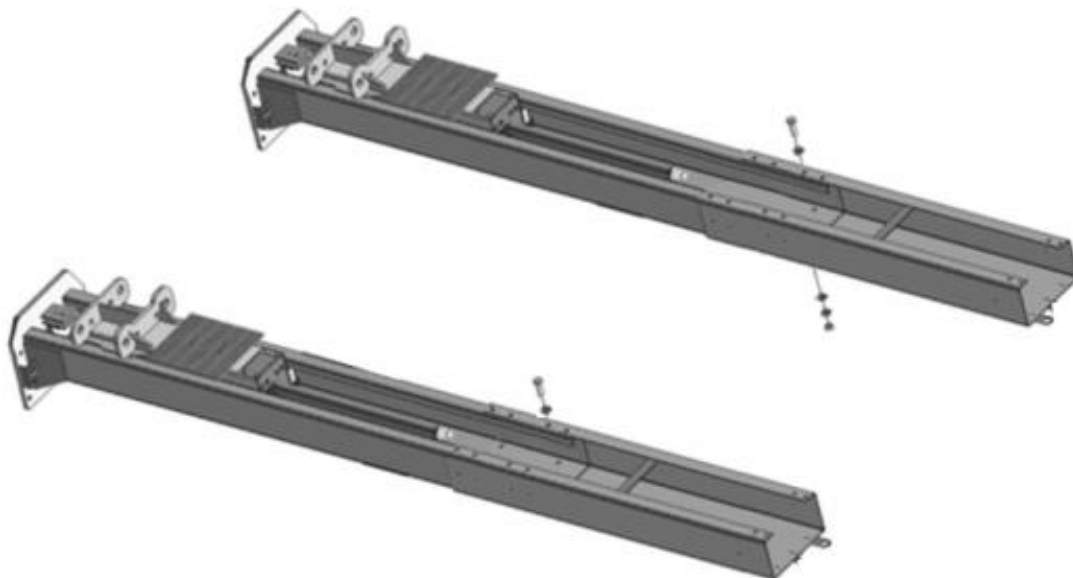

**Low setting
Fig.16**

F. Erect the columns, install anchor bolts, check the columns plumbness with level bar, and adjust with shims if the columns are not vertical.

Do not tighten the anchor bolts. see.Fig.17

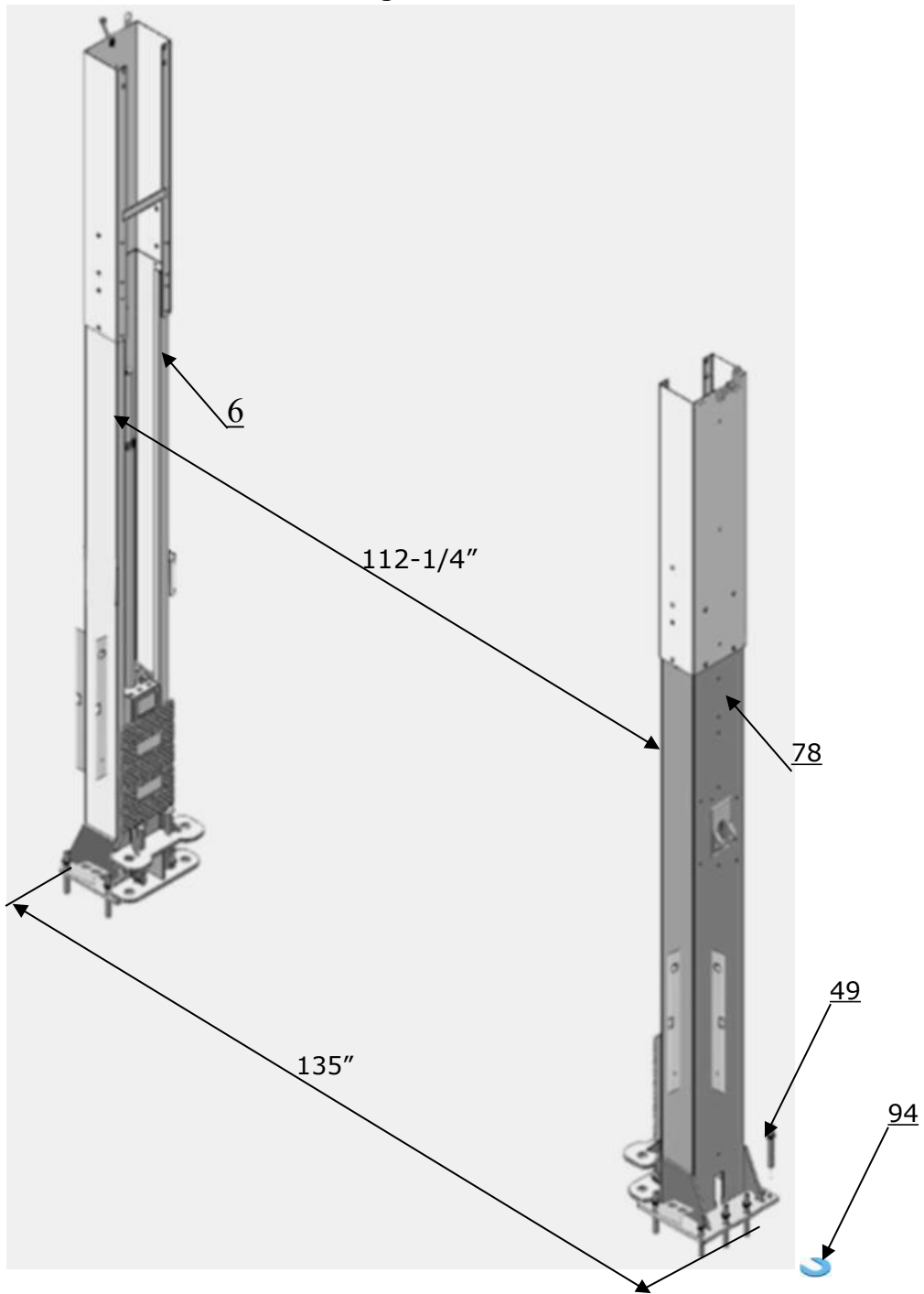

Note: Minimum embedment of anchors is 3-1/2".



Fig. 17

G. Install top beam

1. Hook the top beam(with limit switch) on the power side outer column, align the holes and install the bolts. (See Fig. 18).

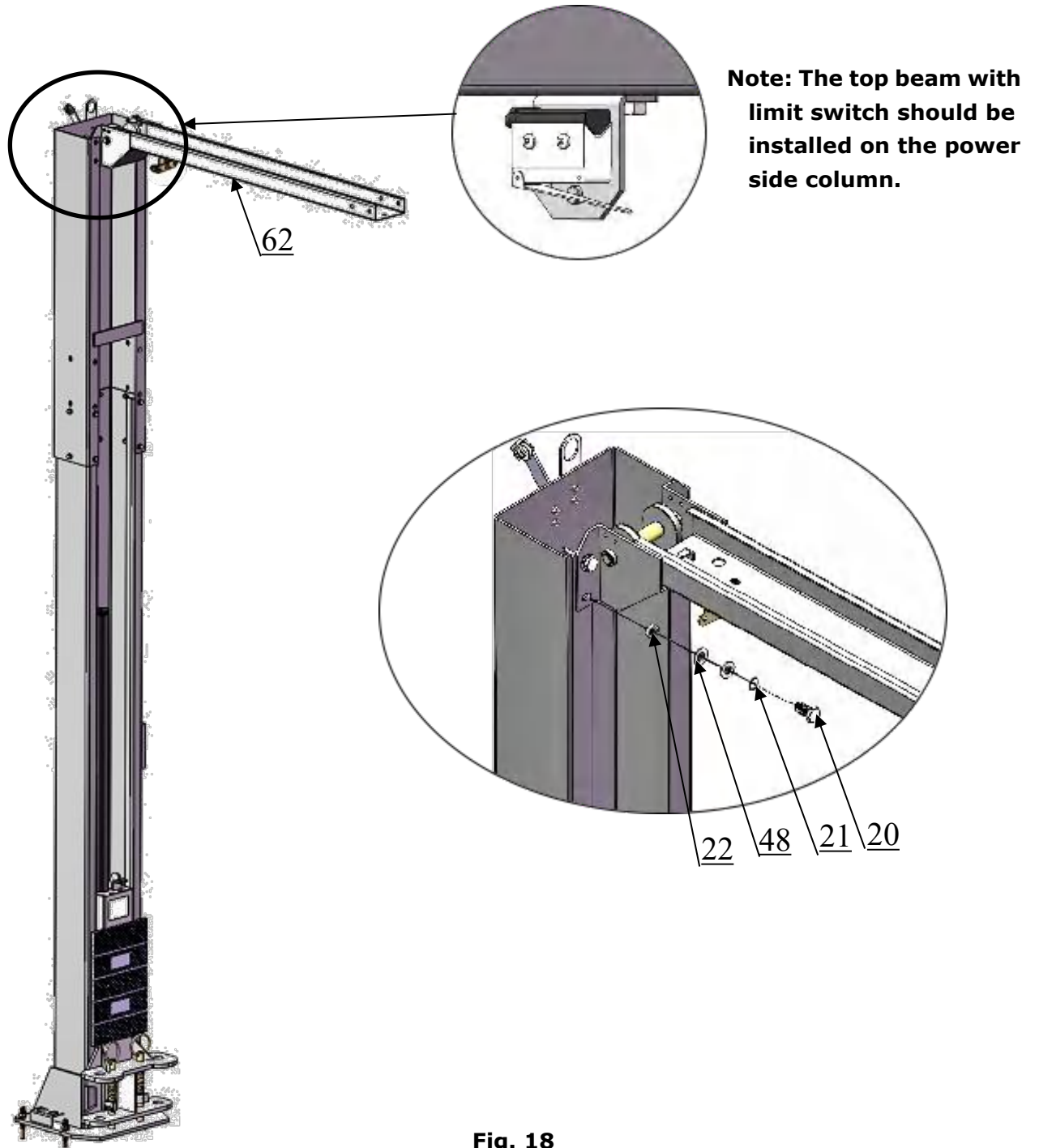

2. After install the other top beam on off side outer column, bolt both top beams and tighten all the bolts. Finally tighten the anchor bolts. (See Fig. 19).

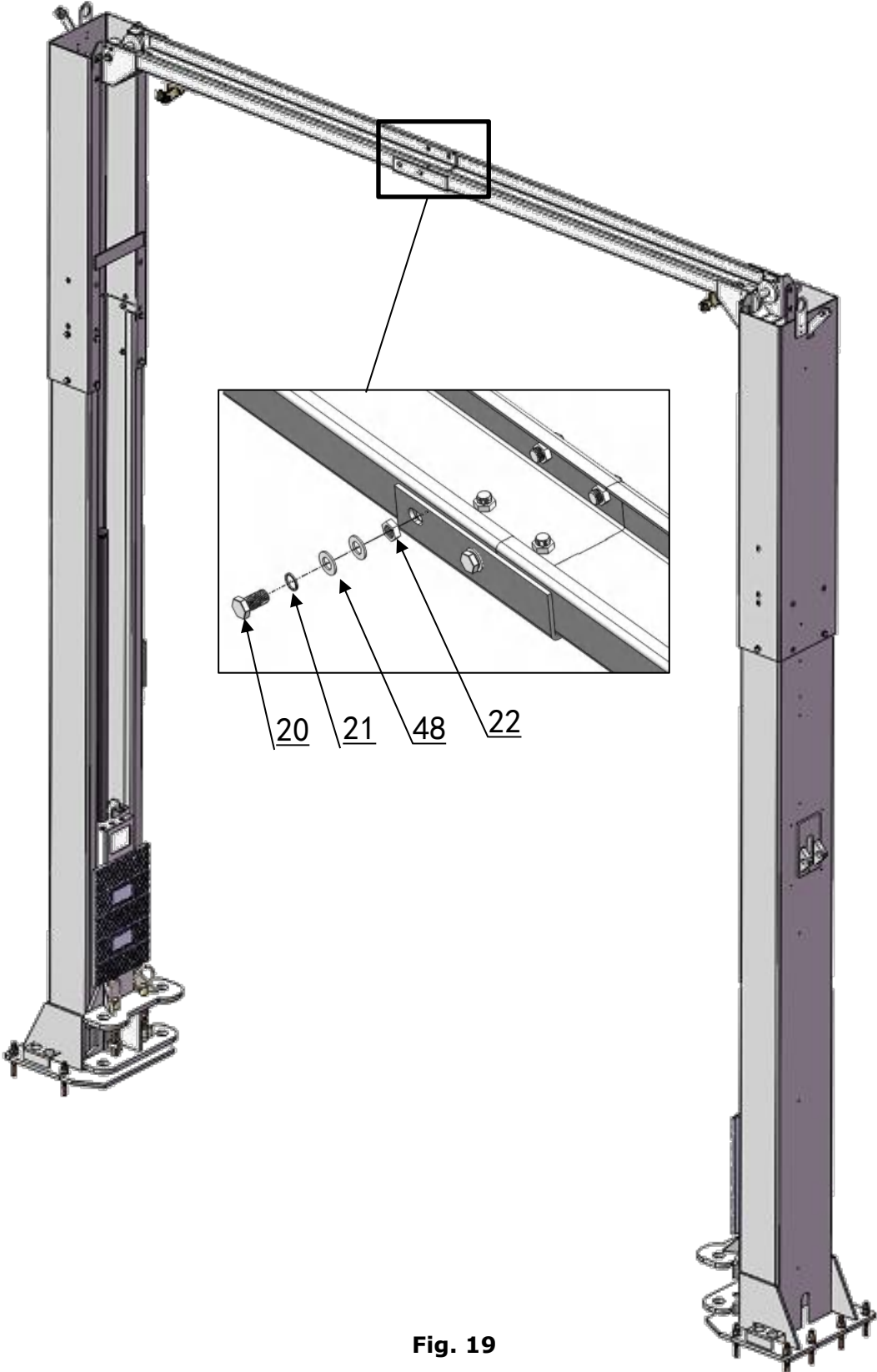

Fig. 19

H. Install control bar for limit switch (See Fig.20)

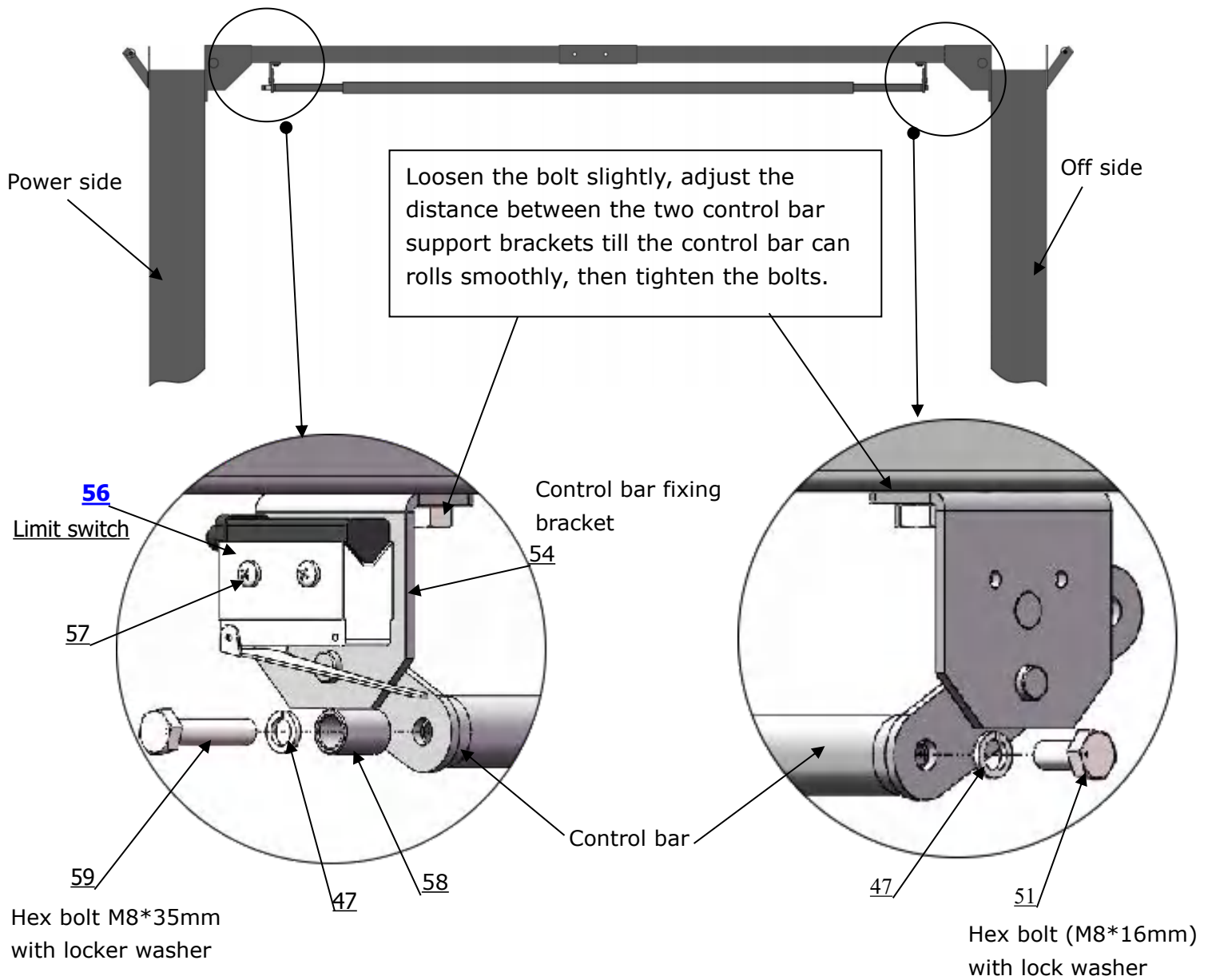
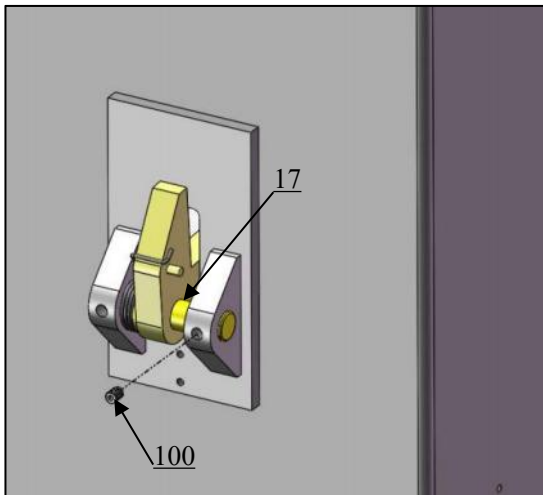

Fig.20

I. safety active block. Install safety device handle.

1. Install the main safety block according to the following steps.



1. Remove the screw

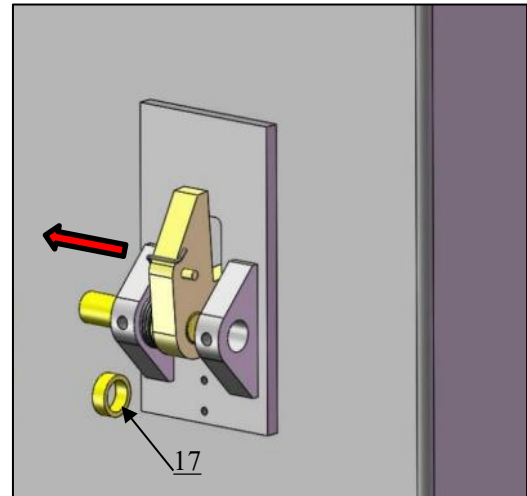

2. Advance the pin in the direction indicated by the arrow until the safety device sleeve can be taken out (No need to take out the pin).

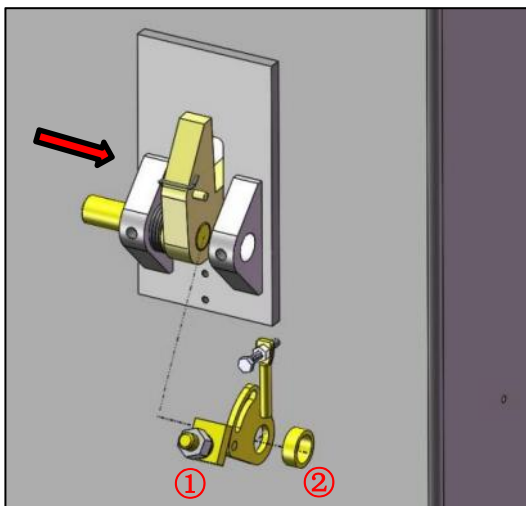

3. Position the safety active block ① and safety device sleeve ② as shown, then insert the pin in the direction indicated by the arrow.

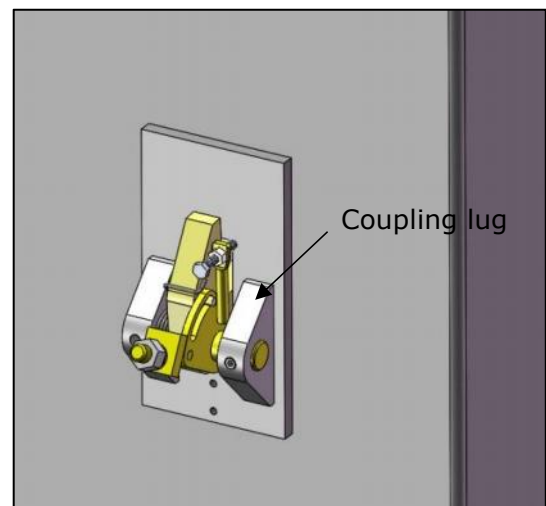

4. Reinstall the pin and fix it in the coupling lug with the screw.

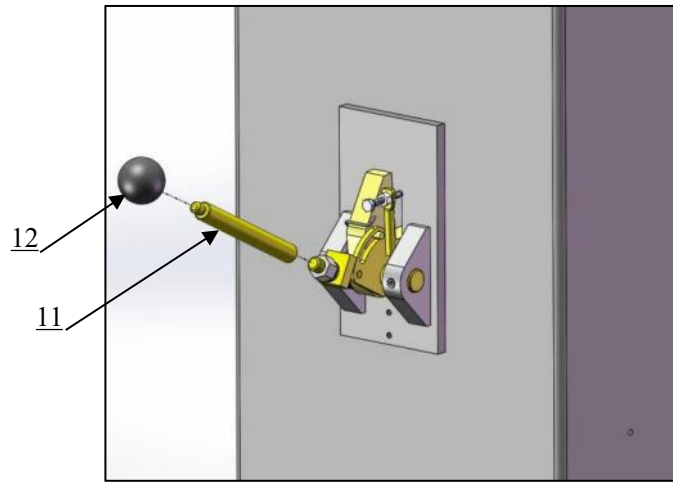

5. Install the safety device handle No.11 and plastic ball No.12 on the safety active block as shown.

Fig.21

Exploded view of safety device

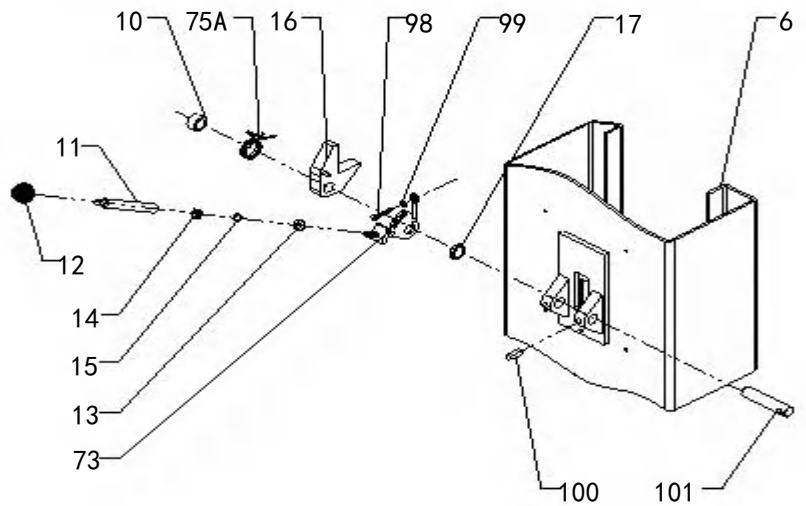
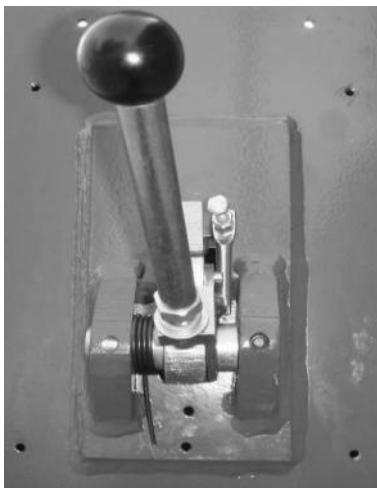
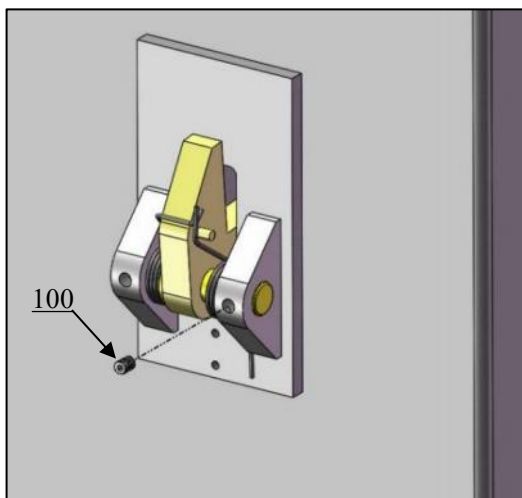
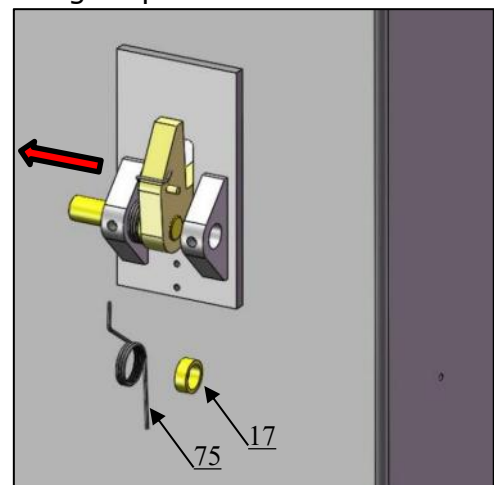

Fig. 22 Power side safety device

2. Install the slave safety block according to the following steps:



1. Remove the screw



2. Advance the pin in the direction indicated by the arrow until the safety device sleeve can be taken out(No need to take out the pin).

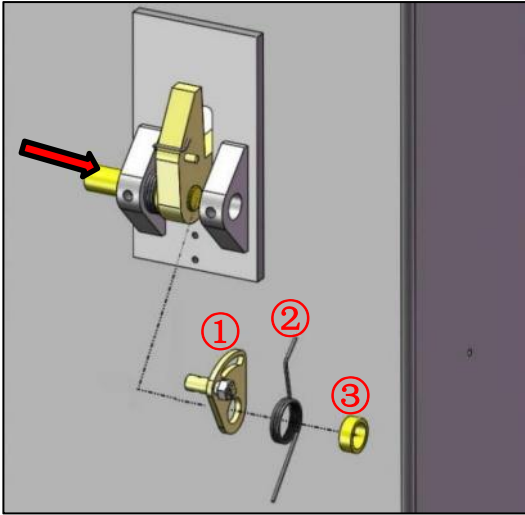

3. Position the slave safety active block ① spring ② and safety device sleeve ③ as shown, then insert the pin in the direction indicated by the arrow, put the elow of spring on the cable connection pin.

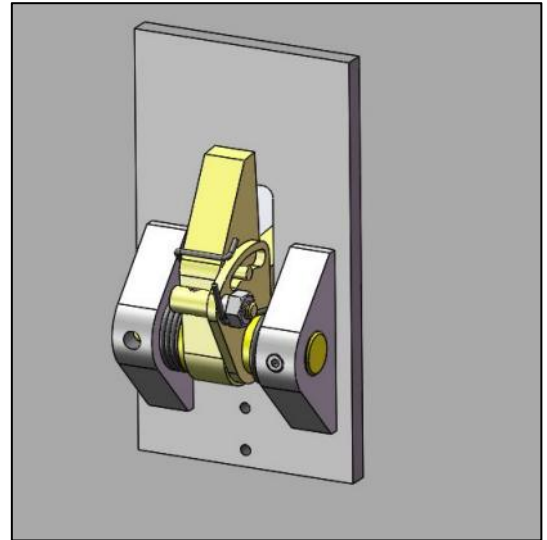

4. Reinstall the pin and fix it in the coupling lug with the screw.

Fig. 23



Fig. 24 Off side safety device

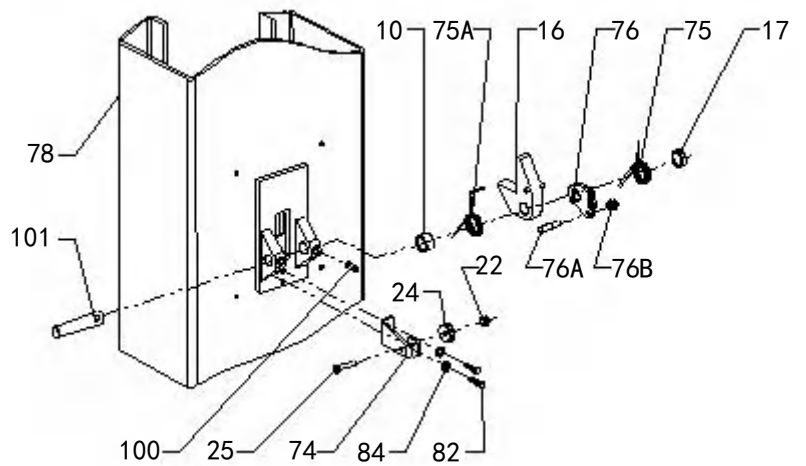

J. Install cables. Raise up the carriages and lock at the same level of safety lock.

1. Low setting cable connection (See Fig. 25).

Note: pass the cable through the inside of carriage

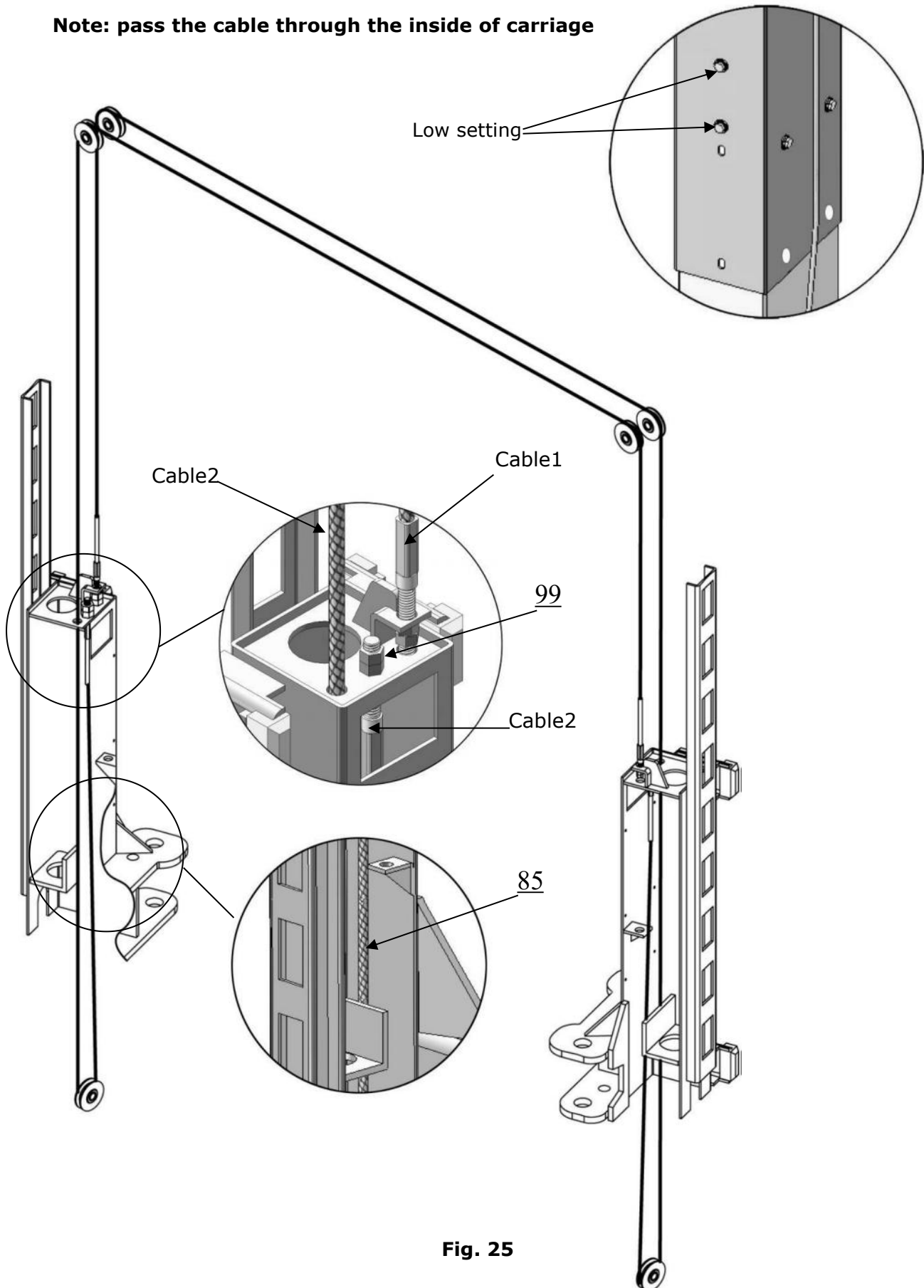
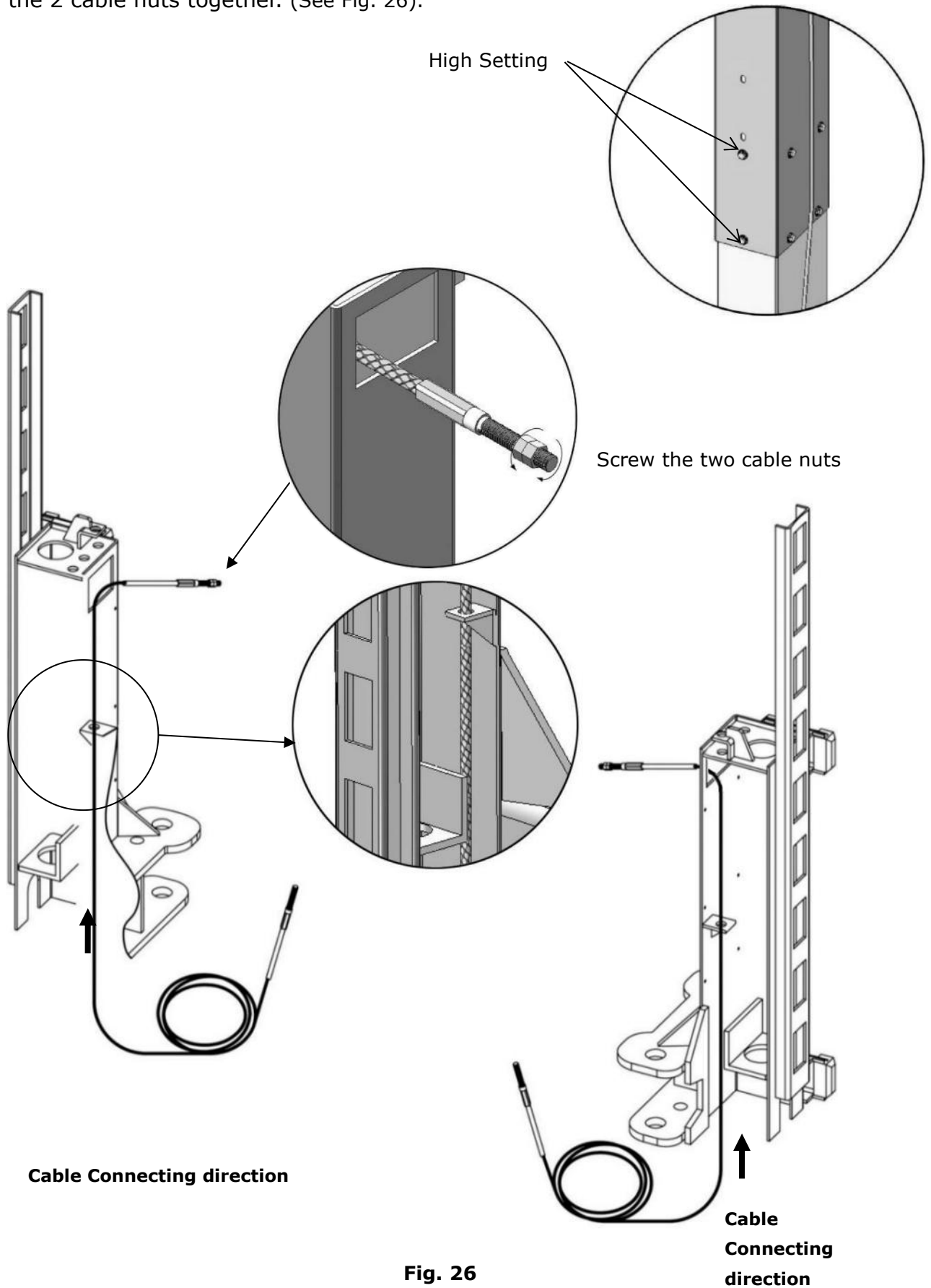

Fig. 25

2. High setting cable connection

2.1. Pass the cable from the bottom of the carriage to the carriage window, then screw up the 2 cable nuts together. (See Fig. 26).



2.2 Cable connection for high setting (See Fig. 27).

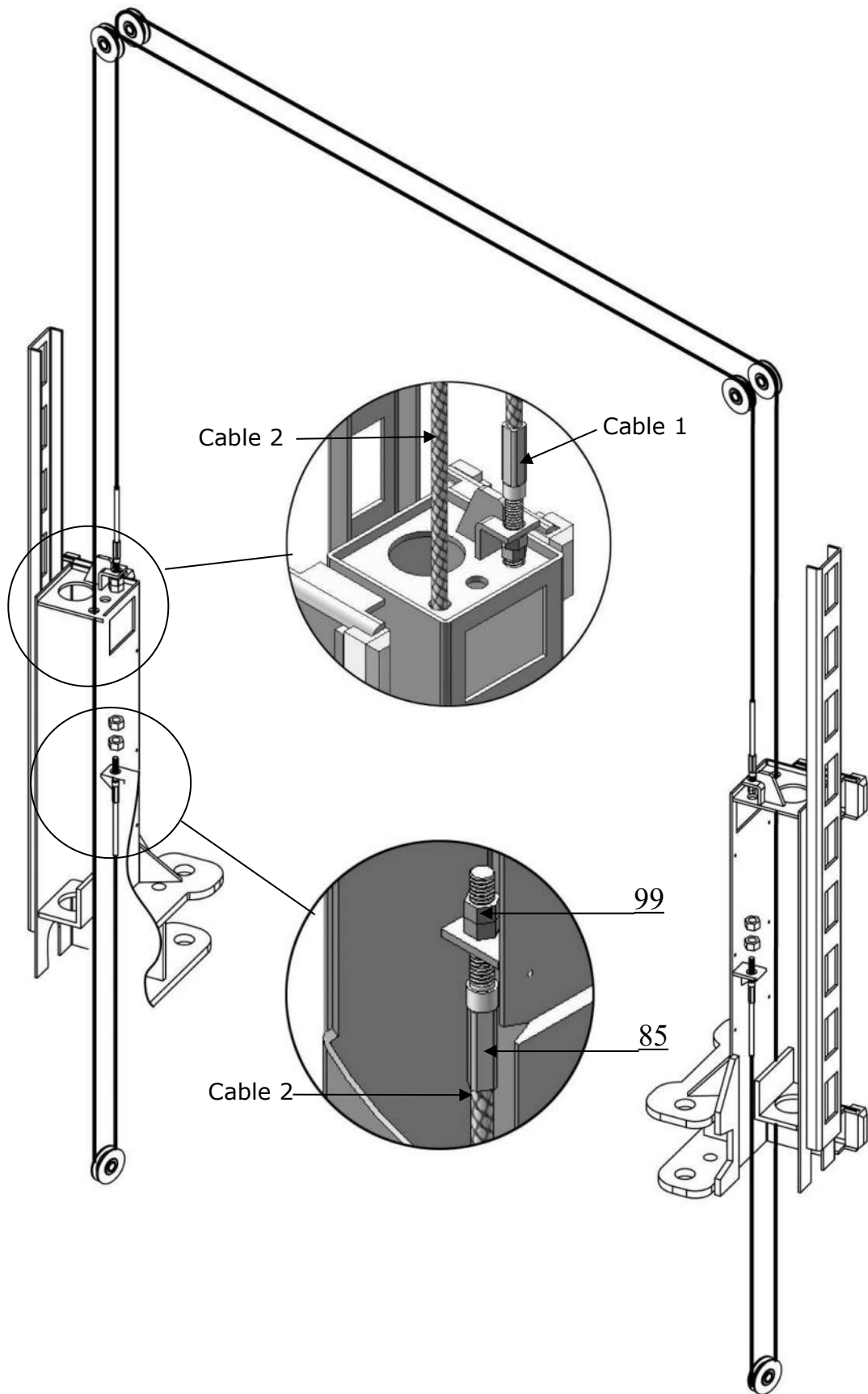

Fig. 27

K. Install hydraulic power unit and oil hose assy.

1. Oil-line connection diagram.

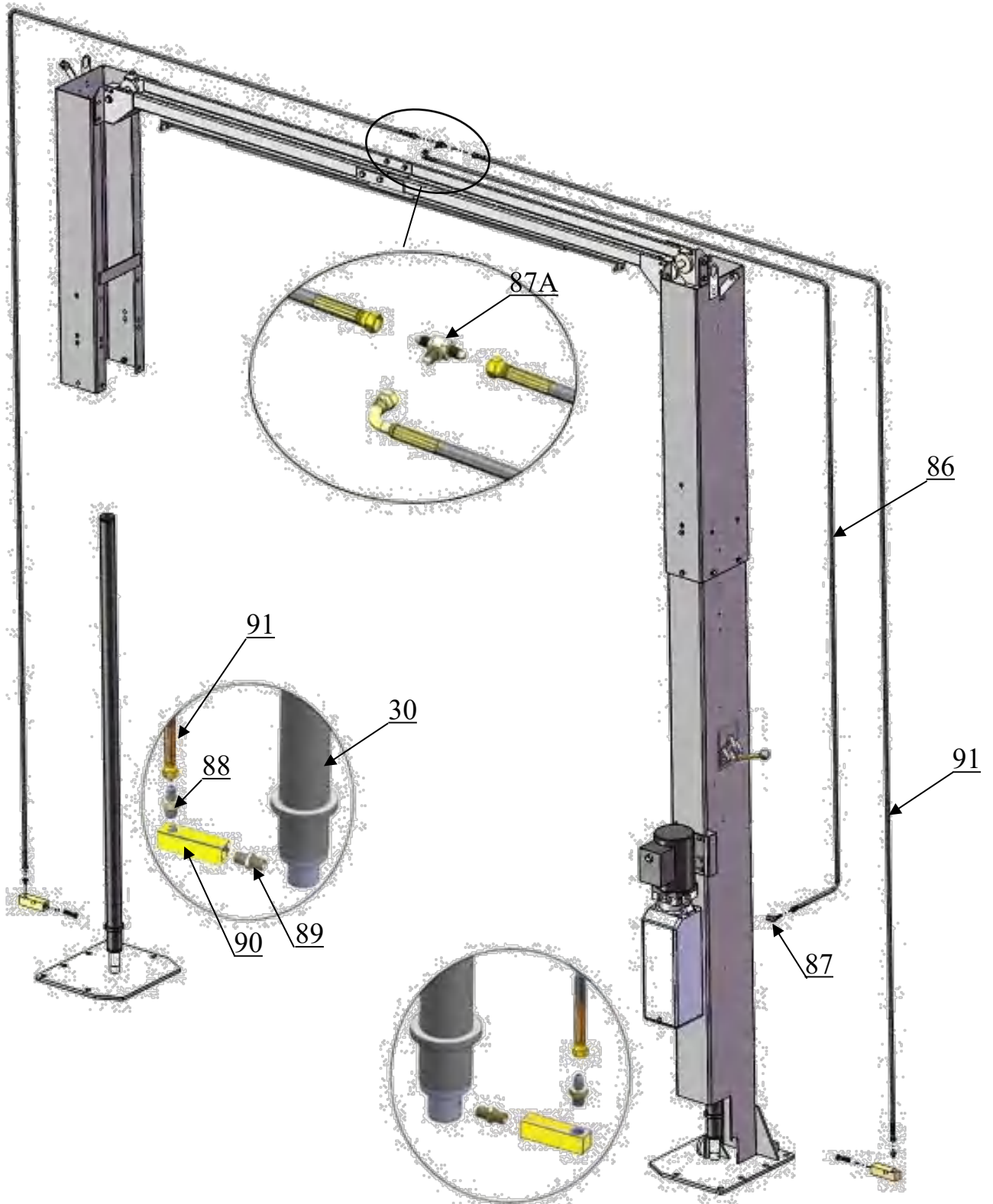

Fig.28

2. Follow these step to connect the oil hose of power unit.

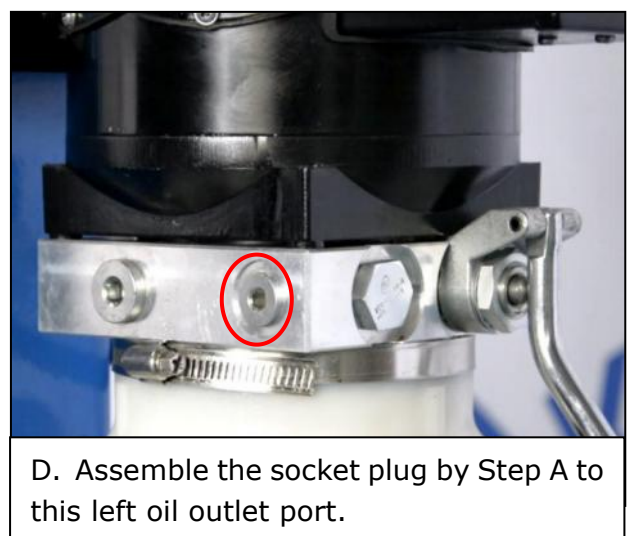
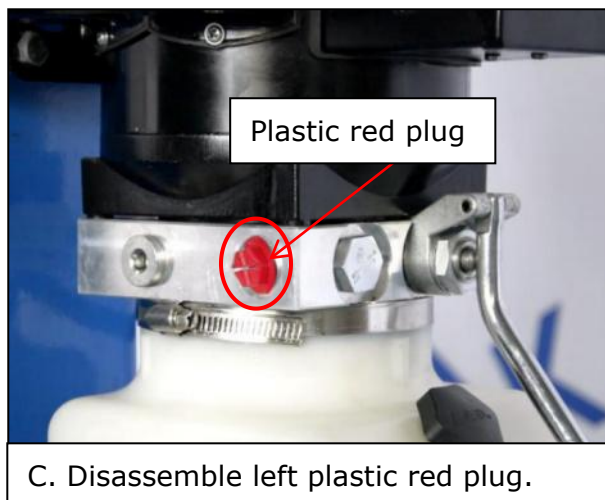
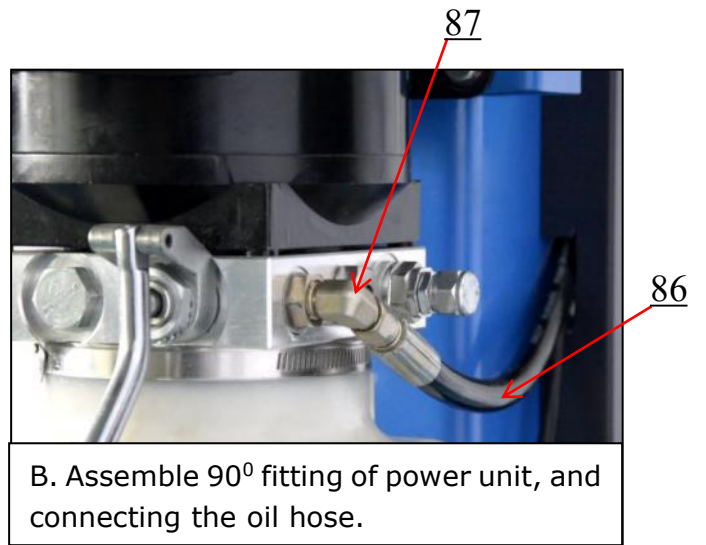
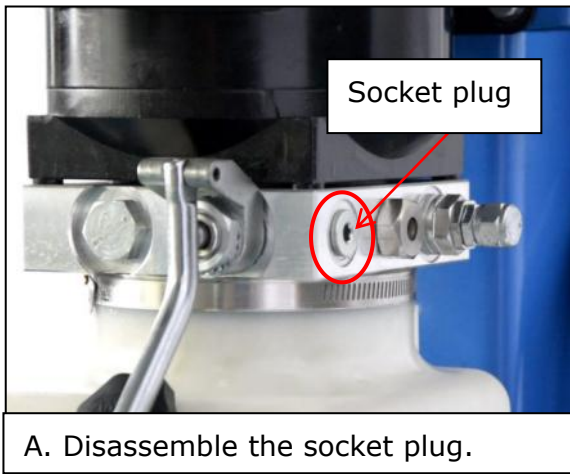
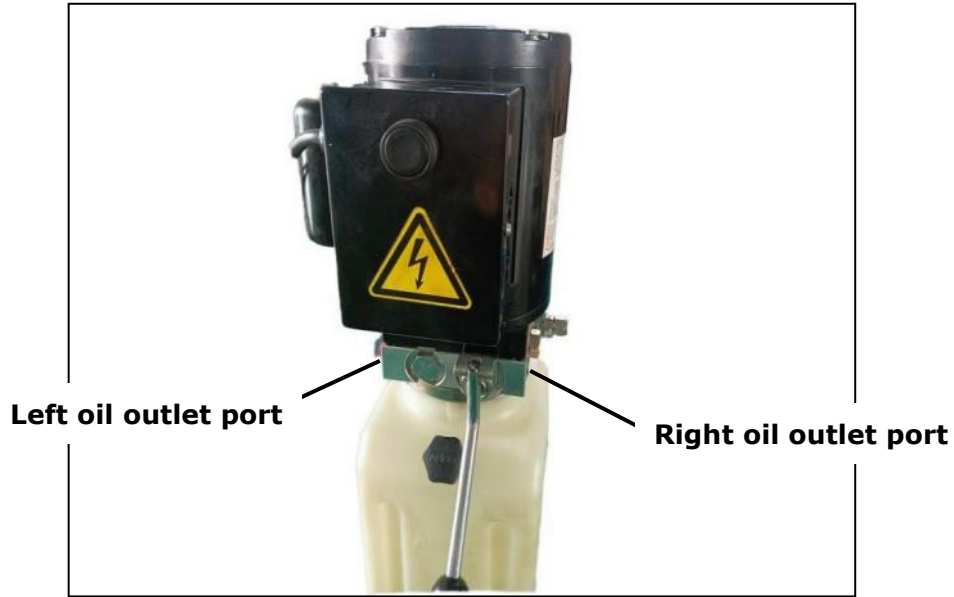
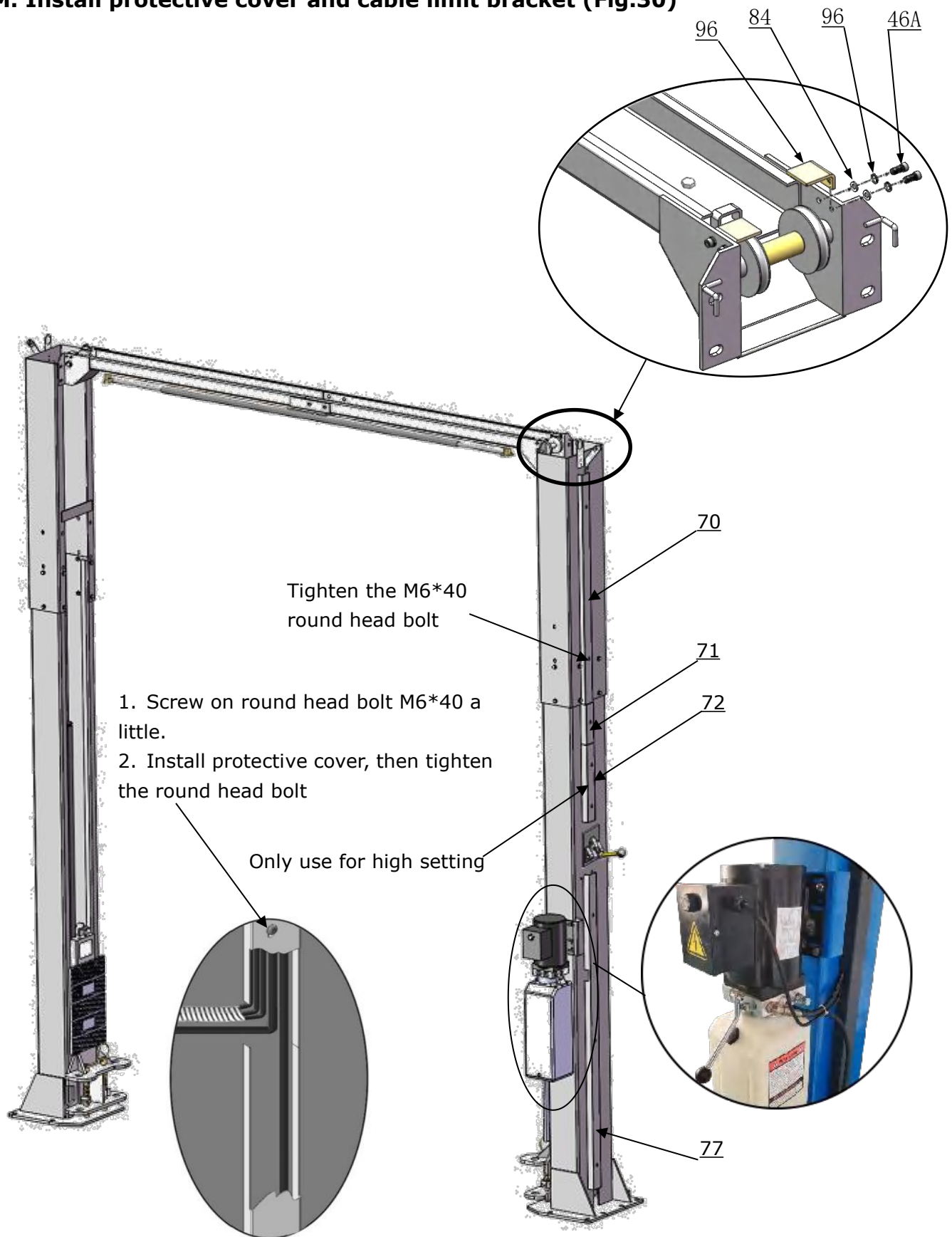

Fig.29

M. Install protective cover and cable limit bracket (Fig.30)



Install protective cover to fix oil hose and bellow pipe

Fig. 30

N. Install lock release cable (See Fig. 31)

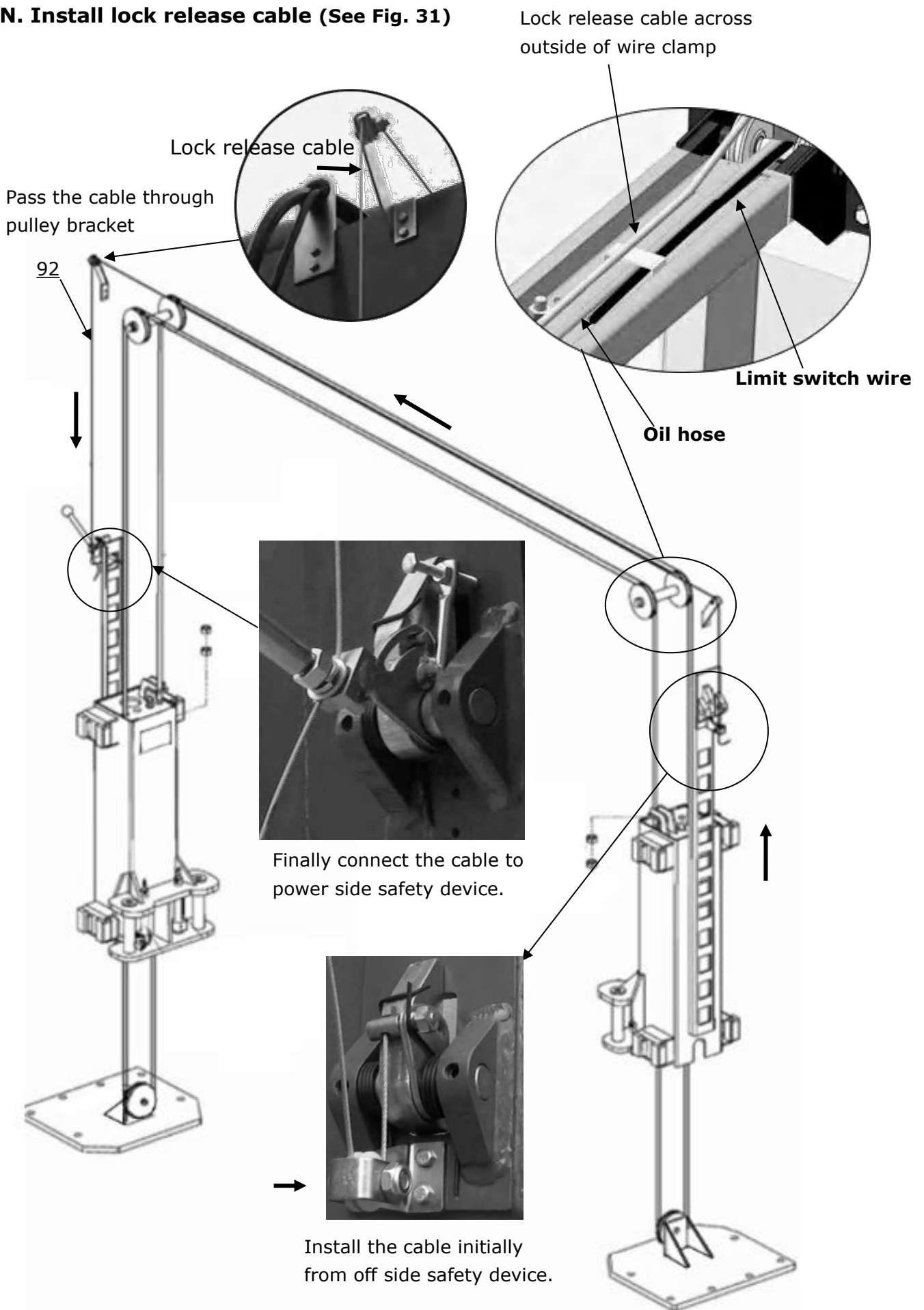

Fig.31

O. Install safety device protective cover.

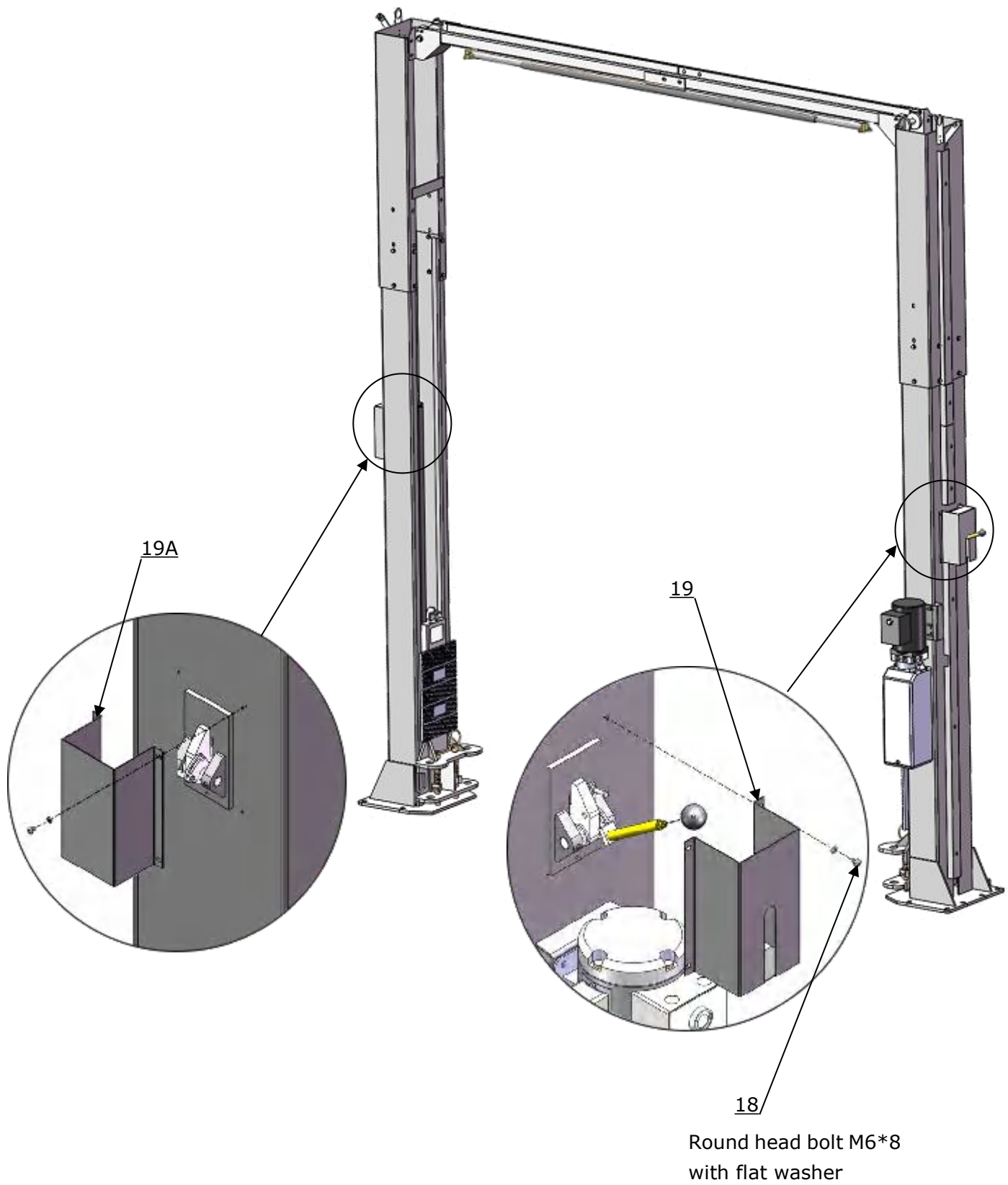

Fig.32

P. Install lifting arms according to figure 33, fix the arm pins with springs, and then install toe guards.

Engagement of moon gear and arm lock:

Lower the carriages down to the lowest position, use 8# socket head wrench to loosen the socket bolt (See Fig. 34), follow the arrow direction to adjust the moon gear (See Fig. 35); tighten the bolts after the moon gear and arm lock are engaged well (See Fig. 36).

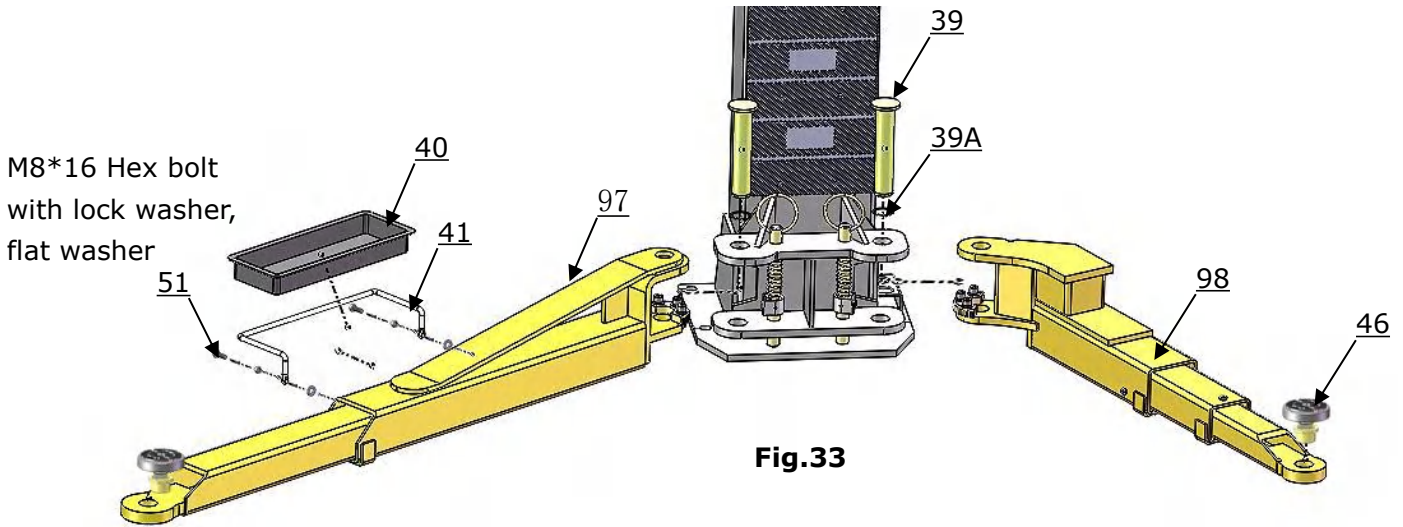
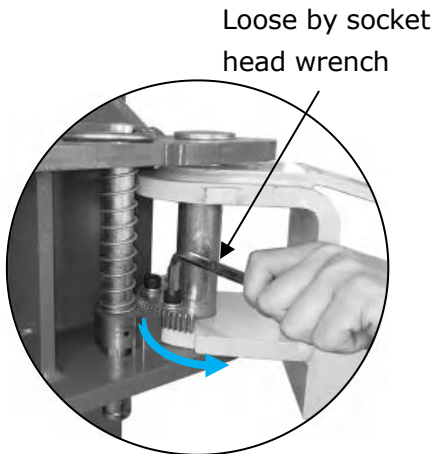

Fig.33

The process of engaging arm lock and moon gear



1. Use 8# socket head wrench to loose the socket bolt

Fig.34

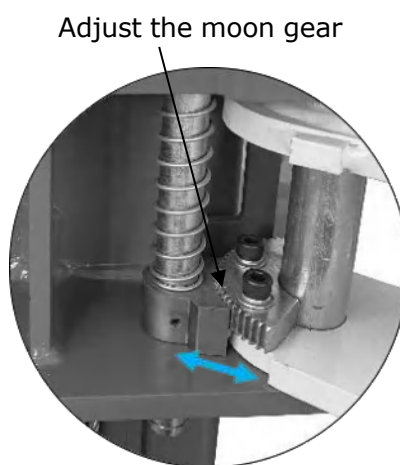

2. Follow the arrow direction to adjust the engagement.

Fig.35

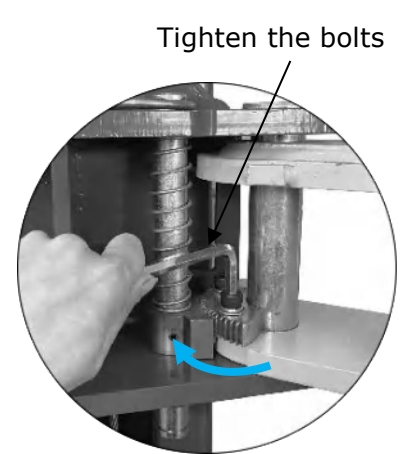

3. Tighten the bolts after the moon gear and arm lock are engaged well

Fig.36

⚠ DANGER Moon gear must be positioned and adjusted correctly. The lift should not be operated until the gears are fully engaged, and it is important to regularly check and adjust the arm restraint gears on all four arms. Failure to do so can result in vehicle damage, injury, or even death.

Q. Tighten all the hydraulic fittings, and fill the reservoir with hydraulic oil.

Note: In consideration of Hydraulic Power Unit's durability and keep the equipment running in the perfect condition, please use Hydraulic Oil 46#.

R. Install electrical system

Connect the power source on the data plate of power unit.

Note:

- 1. Must install limit switch;**
- 2. For safety of operators, the power wiring must contact the floor well;**
- 3. Pay attention to the direction of rotations when using three phase motors.**

Single phase motor

1. The two live wires of the input power supply are respectively connected to the terminals marked L1 and L3 on the AC contactor.

2. Connecting limit switch wire: remove the short wire connecting terminal 4# of control button and A2 of AC contactor firstly (See Fig.38), then according to the wire number of the limit switch, connect them respectively to terminal 4# of control button and A2# of AC contactor. (See Fig. 39)

Internal wiring diagram of limit switch: The cable has been connected.



Fig.37

Motor wiring diagram of single phase power unit

Circuit diagram

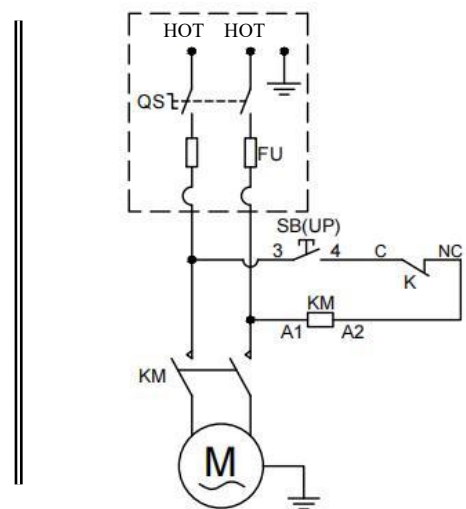
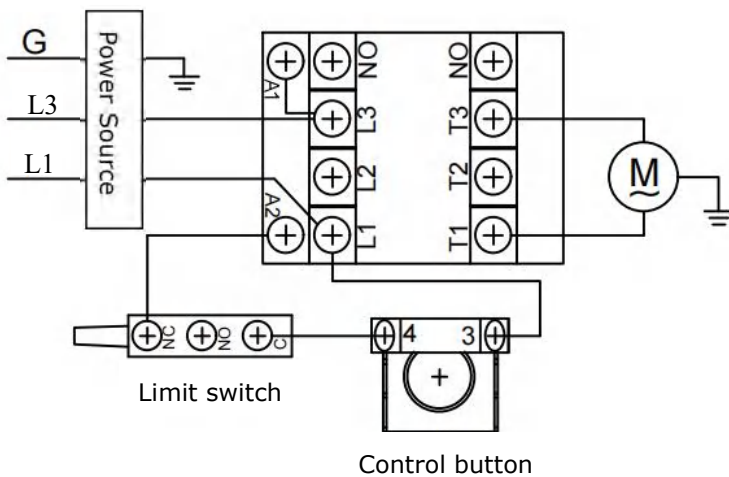

Fig.38

Power supply wires

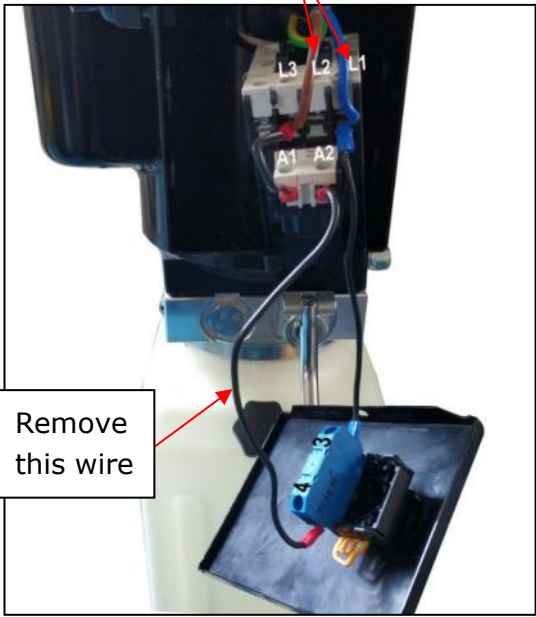

Fig. 39

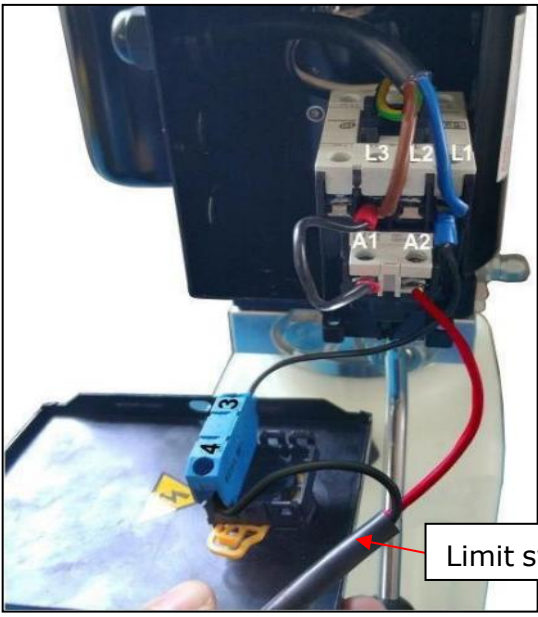

Fig.40

⚠ DANGER All wiring must be performed by a licensed, certified Electrician. If someone who is not a certified Electrician attempts these tasks, they could damage the Lift or be electrocuted, resulting in serious injury or even death.

⚠ DANGER The power unit's motor should not be located in a recessed area or below floor level. Never expose the motor to rain or other damp environments; damage to the motor caused by water is not covered by the warranty.

IV. EXPLODED VIEW

Model: OH-9

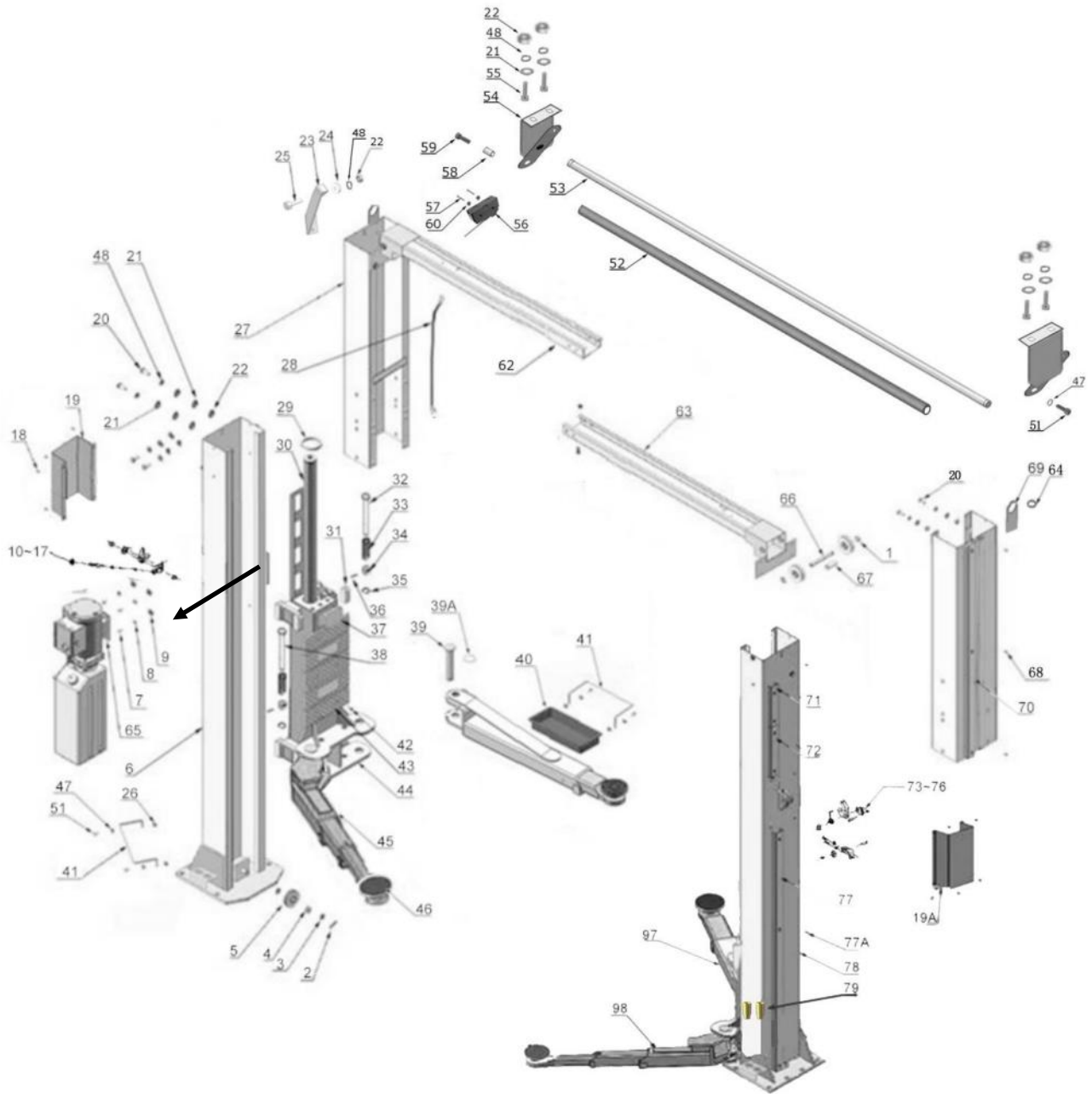

Fig. 41

PARTS LIST

Item	Parts No.	Description	Qty.
1	10206019	Clip ring	4
2	10209012	Snap pin	2
3	10209128	Flat washer ϕ 20	4
4	1002011001	Bronzed bush	6
5	1102011001	Pulley	6
6	11206202-01	Power side column	1
7	10209003	Hex bolt M8*25	8
8	10209004	Rubber ring	4
9	10209005	Nylok nut (M8)	4
10	11217436	Safety device spacer	2
11	11217006	Safety device release handle	1
12	10217005	Plastic ball M10	1
13	10206023A	Hex nut M12	1
14	10420026	Lock washer ϕ 12	1
15	10206006	Flat washer ϕ 12	1
16	11217009	Safety device	1
17	11217012	Safety device spacer	2
18	10209009	Round head bolt M6*8	10
19	11217405	Protective cover (power side)	1
19A	11217406	Protective cover (off side)	1
20	10209125	Hex bolt M10*30	34
21	10209022	Flat washer ϕ 10	72
22	10209021	Hex nut M10	41
23	11217379	Lock release cable bracket	2
24	10206009	Plastic pulley (white)	3
25	10209046	Hex bolt M10*35	2
26	10209033	Flat washer ϕ 8	12
27	11206204	Outer column L=48 13/16"	2
28	10206137	Wire L=145 11/16"	1
29	10209111	Cylinder protective Ring	2
30	C804203	Cylinder	2
31	10209015	Slider block	16
32	11217046A-01	Arm lock bar (left)	2
33	10206050A	Spring	4
34	10217044-01	Arm lock	4
35	10206032	Clip ring	4
36	10206036	Elastic pin	4
37	10209016	Carriage plastic cover	2
38	11217046-01	Arm lock bar (right)	2

Item	Parts No.	Description	Qty.
39	11217168-01	Arm pin	4
39A	10520023	Clip ring	4
40	10206190	Tool Tray (Short)	2
41	11206191	Toe Guard	4
42	10209019	M6*16 flat screw	12
43	10209018	Protective Rubber	2
44	11279004-01	Carriage	2
45	11279013-02	Front right arm assy.	1
46	1101043008-01	Rubber pad assy.	4
46A	10420138	Socket Bolt M6*16	8
47	10209034	Lock washer ϕ 8	15
48	10209039	Lock washer ϕ 10	27
49	10209059	Anchor bolts 3/4*5-1/2	12
50	10206500B	Parts box	1
51	10201002	Hex bolt M8*16	5
52	10206025A	Form tube	1
53	1102022001A-01	Control bar	1
54	1102022003A-01	Control bar fixing bracket	2
55	10206017	Hex bolt M10*20	4
56	1002022001	Limit switch	1
57	10420164	Round head bolt M4*30	2
58	1102022007	Connecting bush	1
59	10201122	Hex bolt M8*35	1
60	10620095	Hex nut M4	2
61	10217011	Hex nut M6	9
62	11206195-01	Top beam A	1
63	11206196-01	Top beam B	1
64	1061K074	Protective ring	1
65		Power unit	1
66	11279016	Pin for pulley	2
67	11206022	Top pulley tube	2
68	10206079	Round head bolt M6*40	14
69	11217024	Oil hose bracket	2
70	11203752	Protective cover L=44 7/8"	2
71	11279624	Protective cover L=7 7/8"	2
72	11203754-01	Protective cover L=15 3/16"	2
73	11217004	Main safety block	1
74	11217029-01	Small pulley bracket	1
75	10217008	Spring	1
75A	10217030	Spring	2
76	11217031	Slave safety block	1
76A	11217032	Cable connecting pin	1
76B	11217033	Nylok nut	1

Item	Parts No.	Description	Qty.
77	11203778-01	Protective cover L=61 7/16"	2
78	11206203-01	Off side column	1
79	1102214016A-01	Stackable adaptor (3")	4
82	10217066	Hex bolt M6*15	10
83	10209149	Lock washer φ6	9
84	10420045	Flat washer φ6	26
85	10206064A	Sync cable assy. L=395 5/8"	2
86	10206132	Oil hose assy. L=176"	1
87	10209060	90° fitting	1
87A	10211016	T Fitting	1
88	10209064	Straight fitting	2
89	10206062	Straight fitting	2
90	11233009	Straight fitting (square)	2
91	10206130-01	Oil hose assy. L=210 5/8"	2
92	10206200	Lock release cable L=305 1/8"	1
93	10209066	Hex Nut	8
94	10201090	Shim (1mm)	10
	10620065	Shim (2mm)	10
95	10209152	Ties	4
96	1102075001-01	Cable limit bracket	4
97	10279014	Rear arm assy.	2
98	11279012-02	Front-left arm assy.	1
99	10209066	M16 nut	8
100	10217051	Socket set screw M10*10	2
101	11217050	Safety device pin	2

4.1 Single Screw Rubber Pad Assy. Exploded View (1101043008-01) :

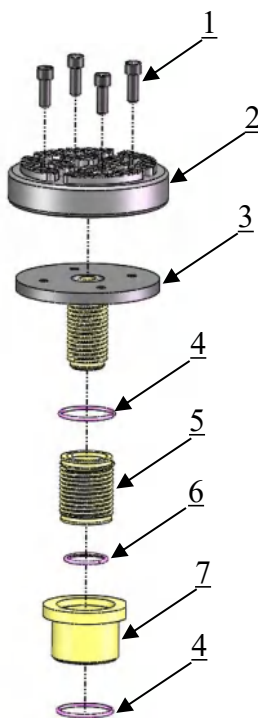

Item	Part No.	Description	Qty.
1	40100001	Socket Bolt M8*12	16
2	10203043-01	Rubber Pad	4
3	1101043003A-01	Support frame	4
4	10203042	Snap ring	8
5	1101043006	Adjusting screw	4
6	10203041	Snap ring	4
7	1101043004	Adjusting sleeve	4

Fig. 42

4.2 Rear arm (10279014) :

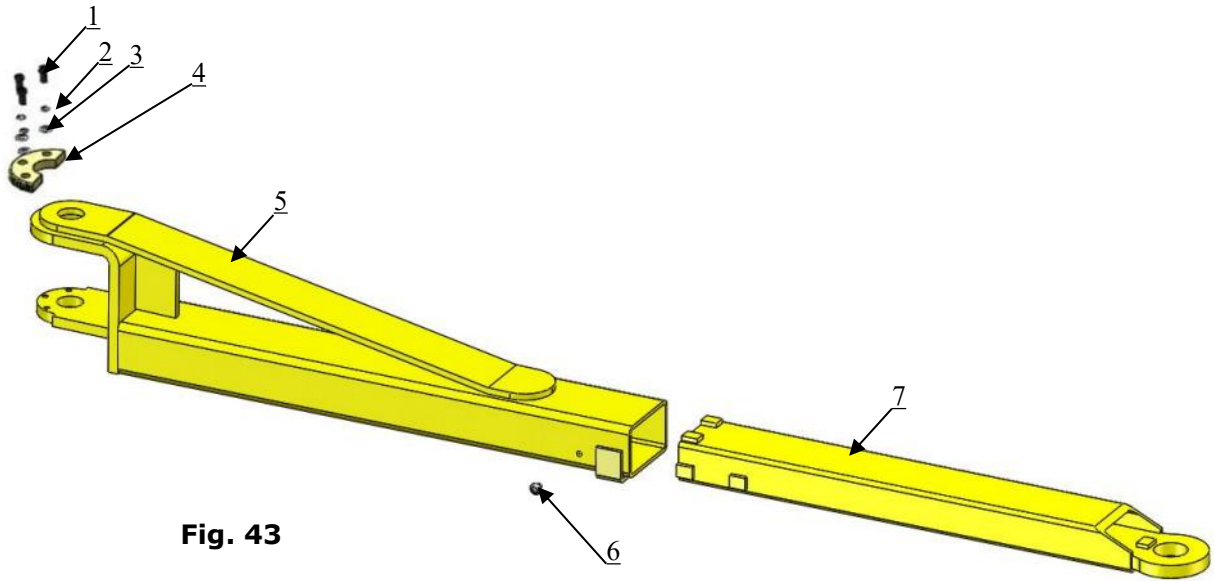

Fig. 43

Item	Parts No.	Description	Qty.
1	10206048	Socket bolt M10*30	6
2	10209039	φ10 lock washer	6
3	10209022	φ10 flat washer	6
4	11206049	Moon gear	2
5	11206192-01	Outer arm	2
6	10201149	Round head bolt M8-12	2
7	11206194-02	Inner arm	2

4.3 Front-left arm (11279012-02) :

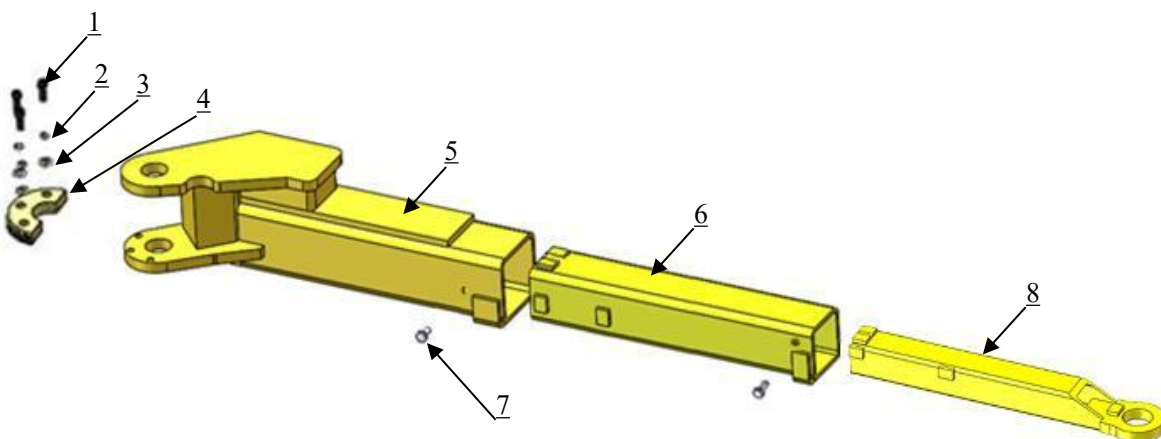

Fig. 44

Item	Part No.	Description	QTY.
1	10206048	Socket bolt M10*30	3
2	10209039	Lock washer φ10	3
3	10209022	Flat washer φ10	3
4	11206049	Moon gear	1
5	11279005-01	Outer arm	1
6	11206189-01	Middle arm	1
7	10201149	Round head bolt M8*12	2
8	11201049B-02	Inner arm	1

4.4 Front-right arm (11279013-02) :

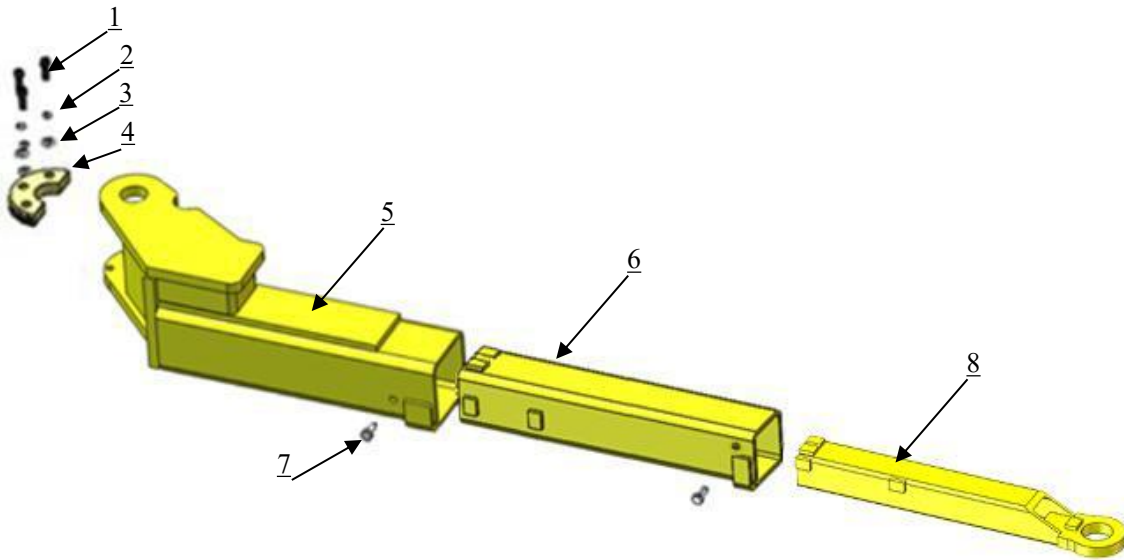

Fig. 45

Item	Part No.	Description	QTY.
1	10206048	Socket bolt M10*30	3
2	10209039	Lock washer φ10	3
3	10209022	Flat washer φ10	3
4	11206049	Moon gear	1
5	11279006-01	Outer arm	1
6	11206189-01	Middle arm	1
7	10201149	Round head bolt M8*12	2
8	11201049B-02	Inner arm	1

4.5 Cylinders C804203 (Old code 10217056)

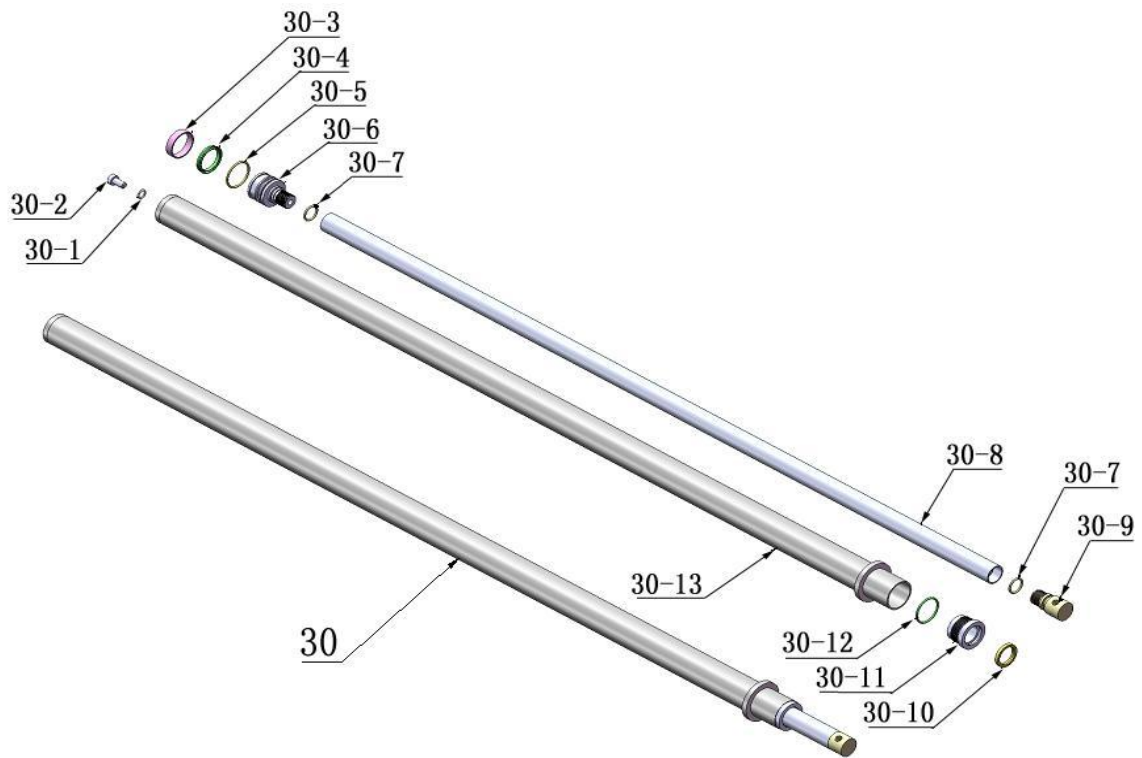

Fig. 46

Parts for Cylinder

Item	Parts No.	Description	Qty.
30-1	10209069	O ring	2
30-2	10209070	Bleeding plug	2
30-3	10209071	Support ring	2
30-4	10209072-01	Y Ring	2
30-5	10209073	O ring	2
30-6	11209074	Piston	2
30-7	11209075	O ring	2
30-8	11217076	Piston rod	2
30-9	11209077	Piston rod fitting	2
30-10	10209078	Dust ring	2
30-11	11209079	Head cap	2
30-12	10209080	O Ring	2
30-13	11209081A	Bore weldment	2

4.6 Illustration of hydraulic valve for hydraulic power unit

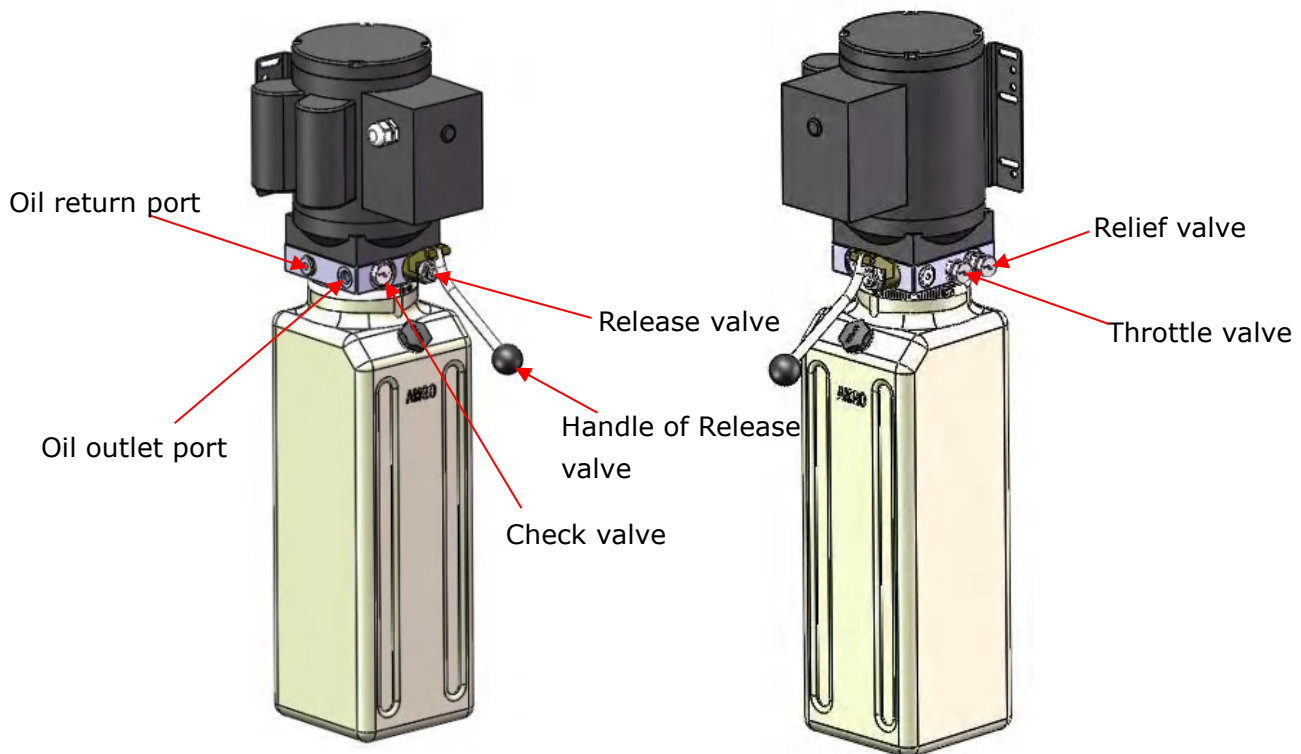

Fig. 47

V. TEST RUN

1. Adjustment of sync cable (See Fig. 48)

Use an open spanner to clamp the cable joint, and use a ratchet wrench to tighten the cable nut until the two sync cables are adjusted to a certain tension force and are consistent. If the carriage on both sides do not run synchronously when the lift rises/falls, tighten the cable nut on the lower carriage until the lift can rise and fall synchronously.

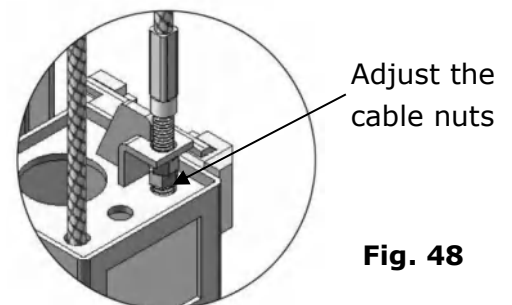

Fig. 48

2. Adjust lock release cable

Lift both carriages and lock them at the same height, strain the lock release cable and then release a little, finally tighten the cable nuts. Ensure that the safety device can always be locked and unlocked properly. At last, install the cover of the safety device.

3. Exhaust air from oil cylinder

This hydraulic system is designed with a bleeding plug, located at the top of the cylinder, raise the carriages to about 1 meter height and loose the bleeding plug, the air would be bled automatically, then tighten the plug after bleeding air, the lift would work stably and smoothly, otherwise, repeat bleeding air.

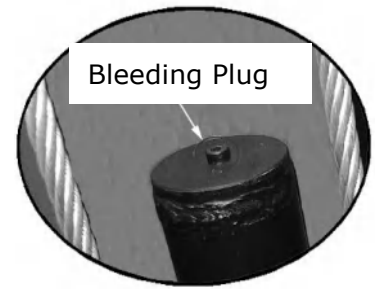
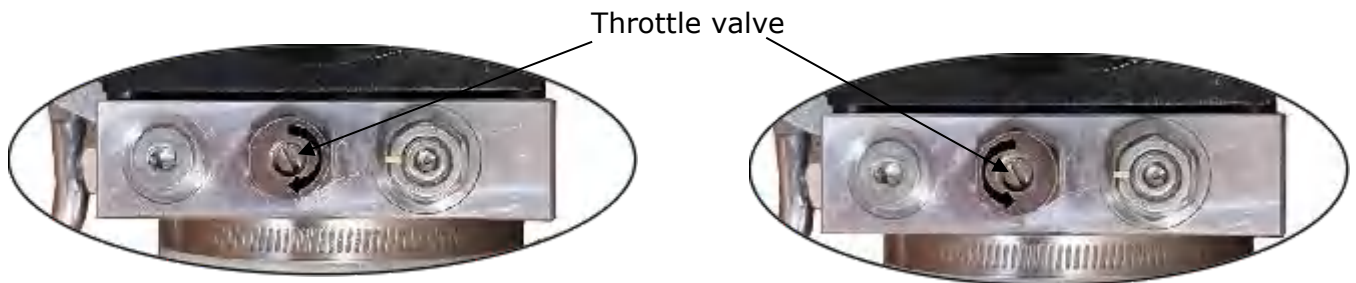

Fig. 49

4. Adjust the lowering speed

If necessary, you can adjust the lower speed of the lift by turning the throttle valve clockwise to decrease it, or counterclockwise to increase the lower speed.



Clockwise to decrease the lowering speed

Counterclockwise to increase lowering speed

Fig. 50

5. Test with load

The test should be conducted after the above adjustments have been completed, test running the lift with typical vehicle. Run the lift at low level several times first, ensure that both side safety lock can lock and unlock in synchronization. When there is no other abnormal phenomenon, run the whole process. Repeat the above adjustment if there is any abnormal phenomenon.

NOTE: It may be vibrated during the first lifting cycles, please lifting it with load for several times, the air would be bled and the vibration would be disappeared automatically.

Hydraulic Schematic Diagram

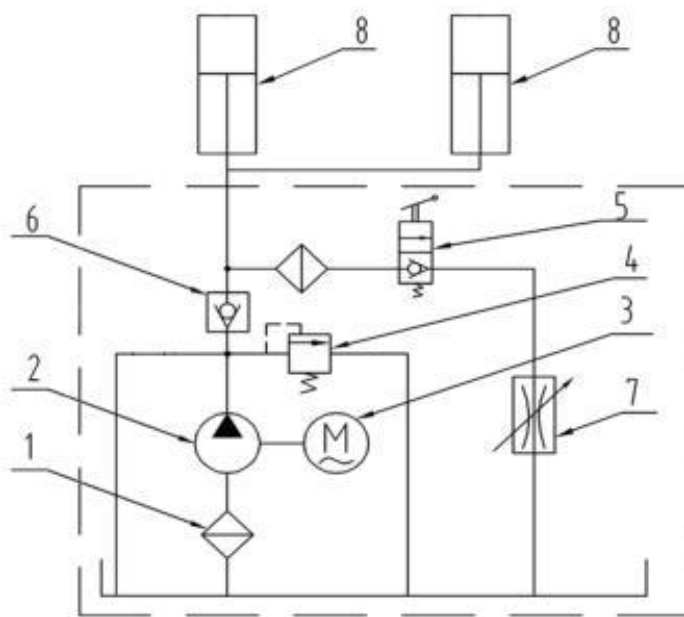

1. Filter
2. Gear pump
3. Motor
4. Relief valve
5. Release valve
6. Check valve
7. Throttle valve
8. Cylinder

Fig. 51

⚠ WARNING Do not lift vehicles that exceed the rated capacity of the lift. Please do not release the safety handle until the lift safety lock is locked. Only trained personnel are authorized to operate the lift.

VI. OPERATION INSTRUCTIONS

Please read the safety tips vehicle carefully before operating the lift

To lift vehicle

1. Keep operation site clean;
2. Lower the lifting arm to the shortest position;
3. Retract the lifting arm to the shortest position;
4. Open lifting arms out to the sides;
5. Move the vehicle between columns;
6. Move the lifting arms to the vehicle's lifting point;

Note: The four lift arms must at the same time contact the vehicle's lifting point where manufacturers recommended

7. Push **UP** button until the lifting pads contact underside of vehicle totally and recheck lifting points;
8. Continue to raise the lift slowly, ensure the balance of vehicle, lift the vehicle to the desired height, release the **UP** button;
9. Press the release handle on power unit to lower the lift to the safety lock position.
The vehicle cannot be repaired unless safety in lock position.

To lower vehicle

1. Clear obstructions around and under the lift and be certain no people are around the lift;
2. Push **UP** button to raise the vehicle slightly, and then unlock the safety device, lower vehicle by pushing release handle on the power unit.
3. Open the lifting arms out to the sides and retract the lifting arm to the shortest position;
4. Drive away the vehicle.

VII.MAINTENANCE SCHEDULE

Monthly:

1. Re-torque the anchor bolts to 150 Nm;
2. Check all connectors, bolts and pins to insure proper mounting;
3. Lubricate cable with lubricant;
4. Make a visual inspection of all hydraulic hoses/lines for possible wear or leakage;
5. Check Safety device and make sure proper condition;
6. Lubricate all Rollers and Pins with 90wt. Gear oil or equivalent;

Note: All anchor bolts should take full torque. If any of the bolts does not function for any reason, DO NOT use the lift until the bolt has been replaced.

Every six months:

1. Make a visual inspection of all moving parts for possible wear, interference or damage;
2. Check and adjust as necessary, equalizer tension of the sync cables to insure level lifting;
3. Check columns for plumbness;

4. Check Rubber Pads and replace as necessary;
5. Check Safety device and make sure proper condition;
6. Check limit switch and make sure in proper condition;
7. Check the oil level of power unit and ensure is normal;
8. Check the moon gear and arm lock and ensure in proper condition.

Oil cylinder maintenance:

In order to extend the service life of the oil cylinder, please operate according to the following requirements.

1. Recommend to use N46 anti-wear hydraulic oil.
2. The hydraulic oil of the lifts should be replaced regularly during using. Replace the hydraulic oil 3 months after the first installation, Replace the hydraulic oil once a year afterwards.
3. Make at least one full trip raising and lowering per day. For exhausting the air from the system, which could effectively avoid the corrosion of the cylinder and damage to the seals caused by presence of air or water in the system.
4. Protect the outer surface of the oil cylinder's piston rod from bumping and scratching, and timely clean up the debris on the oil cylinder dust-ring and the piston rod.

 **DANGER** Ensure that the lift is completely disconnected from the power supply before performing any maintenance on the lift. If your lift external electrical devices have locks/shutdowns, make sure to implement them before performing any maintenance. If you come into contact with high voltage/current, it may result in injury or even death.

VIII.TROUBLE SHOOTING

TROUBLE	CAUSE	REMEDY
Motor does not run	<ol style="list-style-type: none"> 1. Button does not work 2. Wiring connections are not in good condition 3. Motor burned out 4. Height limit switch is damaged 5. AC contactor burned out 	<ol style="list-style-type: none"> 1. Replace button 2.Repair all wiring connections 3. Repair or replace motor 4. Replace the limit switch 5. Replace AC contactor
Motor runs but the lift is not raised	<ol style="list-style-type: none"> 1. Motor runs in reverse rotation 2. Gear pump out of operation 3. Release valve in damage 4. Relief valve or check valve in damage 5. Low oil level 	<ol style="list-style-type: none"> 1.Reverse two power wire 2.Repair or replace 3. Repair or replace 4.Repair or replace 5.Fill tank
Lift does not stay up	<ol style="list-style-type: none"> 1. Release valve out of work 2. Relief valve or check valve leakage 3. Cylinder or Fittings leaks 	Repair or replace
Lift raises slowly	<ol style="list-style-type: none"> 1. Oil line is jammed 2. Motor running on low voltage 3. Oil mixed with air 4. Gear Pump leaks 5. Overload lifting 	<ol style="list-style-type: none"> 1. Clean the oil line 2. Check Electrical System 3. Fill tank 4. Replace Pump 5. Check load
Lift cannot lower	<ol style="list-style-type: none"> 1. Safety device are locking 2. Release valve in damage 3. Lock release cable broken 4. Oil system is jammed 	<ol style="list-style-type: none"> 1. Release the safeties 2. Repair or replace 3. Replace 4. Clean the oil system

 **WARNING** Lifts are dangerous when operated by inexperienced or distracted individuals. Operators must be fully aware that lifting a car is a potentially life-threatening operation, especially if mandatory safety precautions are disregarded.

IX. CAR LIFT SAFETY TIPS

Put these safety tips in a place where you can always alert the operator. Please reference to the lift manufacturer's manual for specific information about the lift.

1. Check the lift daily. If the machine breaks down or has damaged parts, do not operate, and use the parts of original equipment to repair.

2. Do not overload the lift. The rated weight of the manufacturer design is indicated on the label of the lift.

3. Position control of the vehicle and operation of the lift can only be done by a trained and authorized person.

4. You can not lift a car with people inside. When the lift is working, the customer or other people should not be around the machine.

5. Keep the place around the lift clear of obstacles, lubricants, grease, garbage and other debris for a long time.

6. Before driving the car into the lift, put the lifting arm and rubber pad in the proper position to ensure barrier-free space. Do not hit or run over the lift arm and rubber pad of the lift, otherwise it will cause damage to the lift machine or the car.

7. Rise the lift to the required height for operation. Note, if you are working under a car, raise the lift high enough and make sure the safety device has locked.

8. Note, removing (or installing) parts from a car can cause a sudden shift of gravity that is unstable for the raised car. Reference to the car manufacturer's service manual as a recommended procedure when removing parts from the car.

9. Before lower the lift, make sure that the tool tray, tool rack, etc. are removed from under the car. Open the lock before lowering the lift.

10. Before removing the car from the lift, put the lifting arm and rubber pad in place to open an unobstructed exit.

X. LIFT DISPOSAL

When the car lift cannot meet the requirements for normal use and needs to be disposed, it should follow local laws and regulations.



Address:

SC Division: 1931 Joe Rogers Jr Blvd, Manning, SC 29102, USA

TX Division: 4310 Adler Dr., Suite #200, Dallas, TX 75211, USA

<http://www.amgohyd.com>

Manual No.: 72228009
Revision Date: 2026/01