

# TWO POST LIFT



## SPECIFICATIONS

Model	OH-12	OH-12S
Lifting Capacity	12,000 lbs	12,000 lbs
Lifting Time	69s	69s
Max. Lifting height: (w/o extension adapter)	72 1/2"~73 7/8"	72 1/2"~73 7/8"
Max. Lifting height: (w/ extension adapter)	81 9/16"~82 7/8"	81 9/16"~82 7/8"
Max. lock height: (w/o extension adapter)	70 9/16"~71 7/8"	70 9/16"~71 7/8"
Max. lock height: (w/ extension adapter)	79 9/16"~80 15/16"	79 9/16"~80 15/16"
Overall Height:(low setting)	174"	143 1/8"
Overall Height:(medium setting)	186"	155 1/8"
Overall Height:(high setting)	198"	167 1/8"
Overall Width	C 150 3/4"	150 3/4"
Drive-Thru Clearance	D 109 3/4"	109 3/4"
Width Between Columns	E 123 1/2"	123 1/2"
Minimum Pad Height	F 4 1/2"	4 1/2"
Gross Weight	2,436 lbs	2,183 lbs
Motor	2.0HP, 220V 60Hz, single phase	

## TWO-POST HEAVY-DUTY LIFTS

*Crafted for power, AMGO offers two innovative designs with a boasting capacity of 12,000 lbs. They maximize your shop's full potential, featuring four heavy-duty three-stage arms that ensure versatility in catering to various vehicles, and integrate AMGO's 3-in-1 technology to accommodate different ceiling heights. The OH-12S is specifically designed for garages with restricted ceiling heights of less than 14 feet, while the OH-12H features an extra-high profile reaching up to 16.5 feet.*

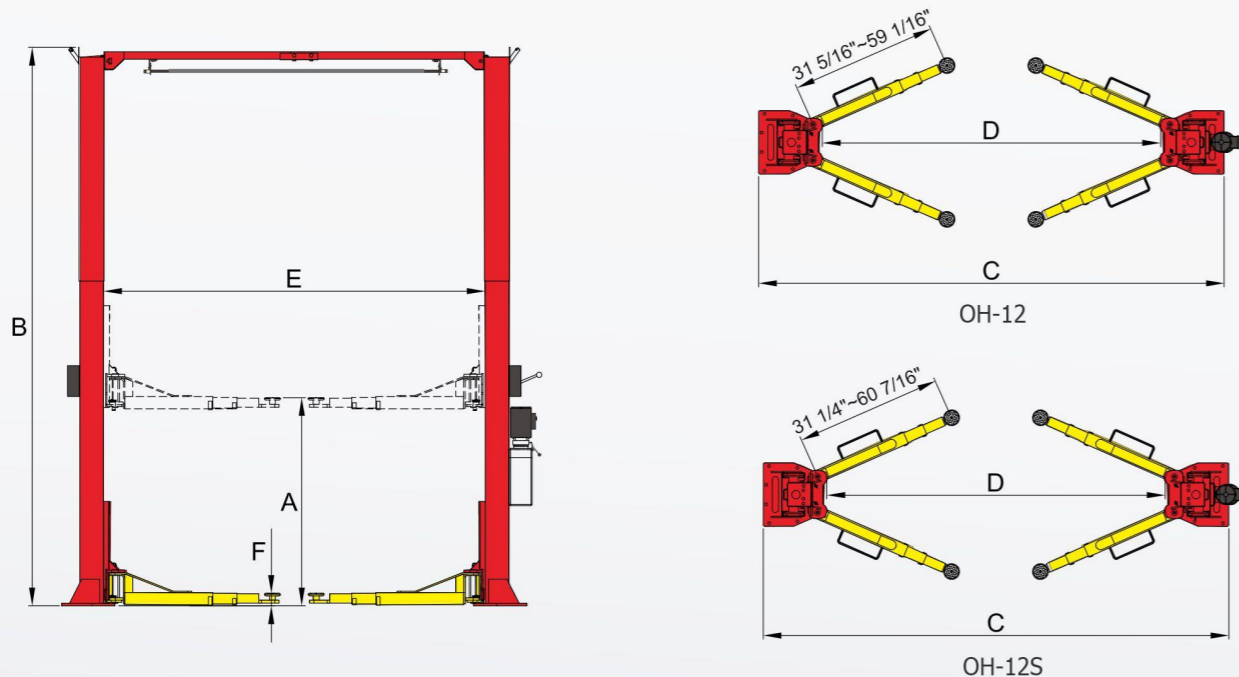

### AMGO HYDRAULIC CORPORATION

SC Division: 1931 Joe Rogers Jr Blvd, Manning, SC 29102, USA  
Tel:(803)505-6410

TX Division: 4310 Adler, Suite 200, Dallas, TX 75211,USA  
Tel:(214)377-8091



OH-12

OH-12S

**OH-12**  
**12,000lbs**

**OH-12S**  
**12,000lbs**

- ✓ Lifting capacity: 12,000 lbs;
- ✓ High quality dual hydraulic direct-drive cylinders;
- ✓ 4 three-stage arms provide the flexibility to lift vehicles from short to long wheelbases;
- ✓ Single-point manual safety lock release that simultaneously unlocks both columns from one side;
- ✓ The clear-floor design provides an unobstructed workspace;
- ✓ The overhead safety shut-off device for maximum vehicle protection;
- ✓ Exclusive: adjustable three height setting accommodates varying service ceiling heights;
- ✓ Self-lubricating UHMW polyethylene sliders;
- ✓ Automatic arms restraint;
- ✓ Areo sync cables come as standard;
- ✓ Detachable toe guard and tool tray come standard;
- ✓ Heavy-duty single-screw rubber pads and saddle adapters come as standard;
- ✓ 3" and 6" extension adapters come as standard.



Heavy duty single screw rubber pads and saddle adapters come standard.(only OH-12)



Both 3" and 6" extension adapters come as standard.



Optional heavy duty extreme wide saddle adapter. Kits No. 21109



Standard heavy-duty 3-stage arms (P/N of Lifting arm assy.:102854001C-01).

**FEATURES**



• Single point safety release makes it easier for operators to unlock both columns from one column.



• Automatic arm restraints.



• The pulley with Self-lubricating bronze bush



• The optional base plate extension Kits No.21501.

**LESS MAINTENANCE,  
MORE RELIABLE**

OH-12, OH-12S Two post lifts are the developed by AMGO for heavy duty purpose with a lifting capacity up to 12,000lbs. Heavy-duty construction, self-lubricating bush, sliders and high quality parts to make the lifts with almost no maintenance required.

5-3-2 warranty:  
5 years for steel construction, 3 years for hydraulic parts, and 2 years for electrical components.