

AMGO  [®] **Hydraulics**

Original

Installation And Service Manual

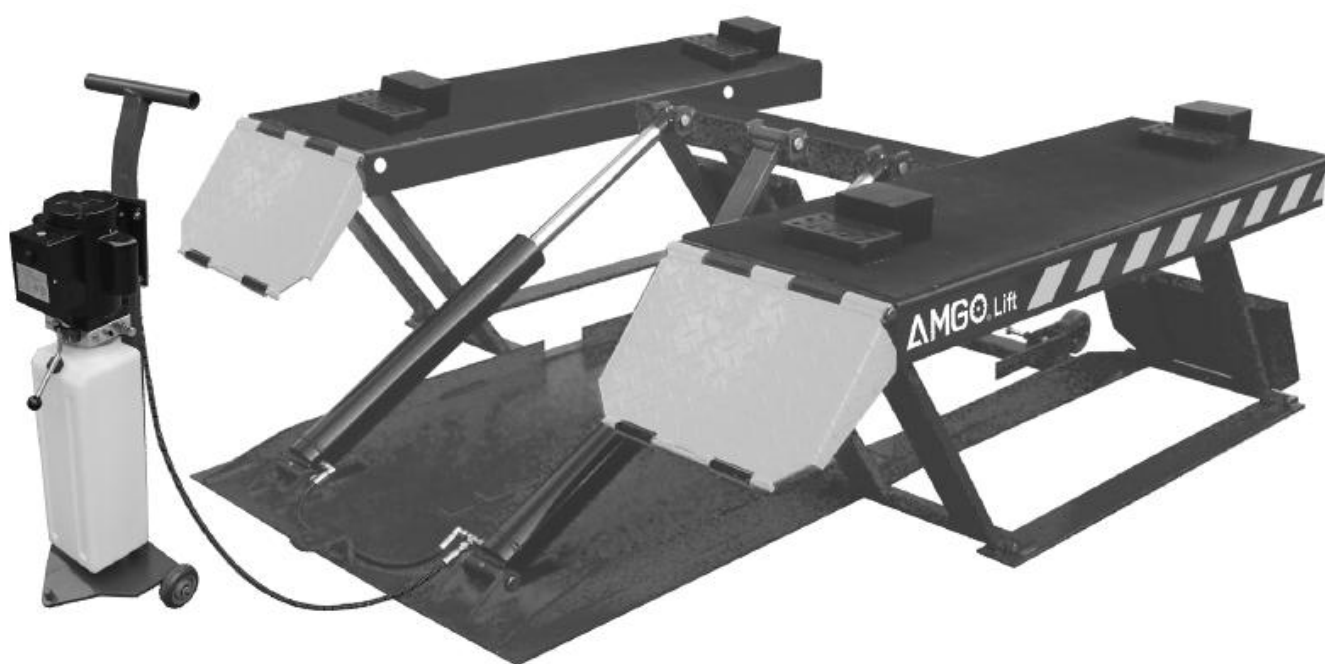

**Portable Low-rised scissors lift
Model:LR10**

CONTENTS

Product Features and Specifications	1
Installation Requirement	2
Step of Installation	3
Exploded View	7
Operation Instructions	12
Maintenance Schedule	14
Trouble Shooting	15
Lift disposal	15

I. PRODUCT FEATURES AND SPECIFICATIONS (See Fig.1)

PORTABLE LOW-RISED MODEL LR10

- Self-locking safety device: 3 stage safety lock, mechanical lock, automatic release.
- Portable unit is easy to move with the power unit stand.
- Double cylinder design.
- Multifunctional drive-in ramp, can also used as extension platform.
- Multi-points mechanical locks with gravitational lock release mechanism.
- Standard rubber pads included

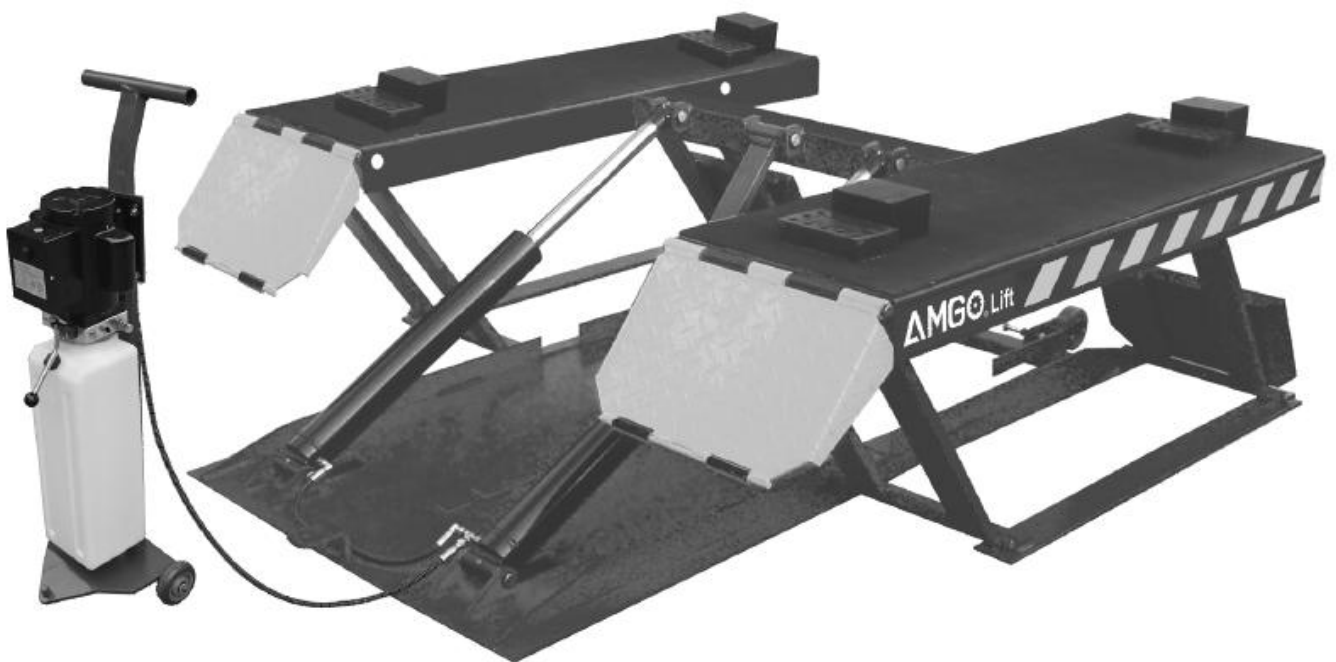

Fig.1

MODEL LR10 SPECIFICATIONS

Model	Lifting Capacity	Raised Height	Lifting Time	Overall Length	Overall Width	Lowered Height	Runway Width	Runway Length	Gross Weight	Motor
LR10	10000 LBS	23 5/8"	90S	76 1/4"	70"	4 1/8"	18"	53 1/4"	1,069lbs	2.0 HP

II. INSTALLATION REQUIREMENT

A. Tools requirement

↳ Screw Set



↳ Socket Head Wrench (8")



↳ Wrench sets: (13#, 15#, 17#, 19#)



↳ Grease gun



↳ Pliers



Fig.2

B. Power requirement

The electrical source must be 2.2KW minimum. The source cable size must be 2.5mm² and in good condition of contacting with floor.

III. STEPS OF INSTALLATION

A. Check the parts before assembly, make sure all the parts are completed.

1. Packaged lift, Parts box, Power Unit and Power Unit Stand.

Move aside the parts, Open the outer packing and check the parts according to the shipment parts list (**See Fig. 3**).

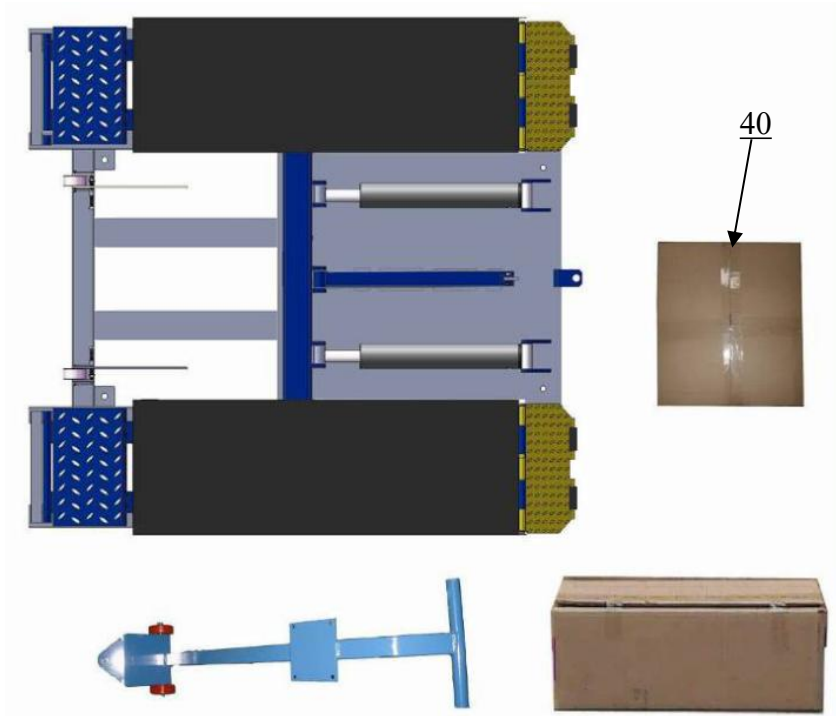

Fig. 3

2. Open the parts box, check the parts according to the part list (**See Fig. 4**).



Fig. 4

3. Check the parts of the parts bag according to the parts bag list (See Fig. 5).



Fig. 5

B. Install hydraulic power unit (See Fig. 6)

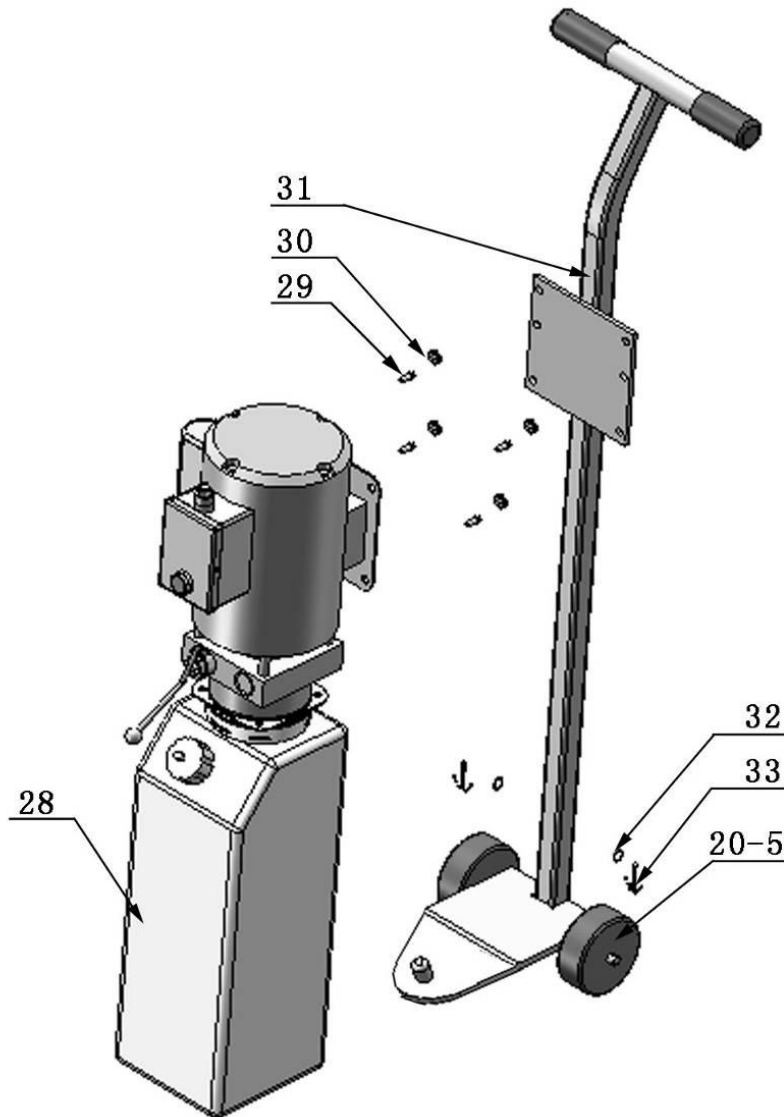

Fig. 6

C. Install fitting to power unit, and then connecting oil hose (See Fig.7).

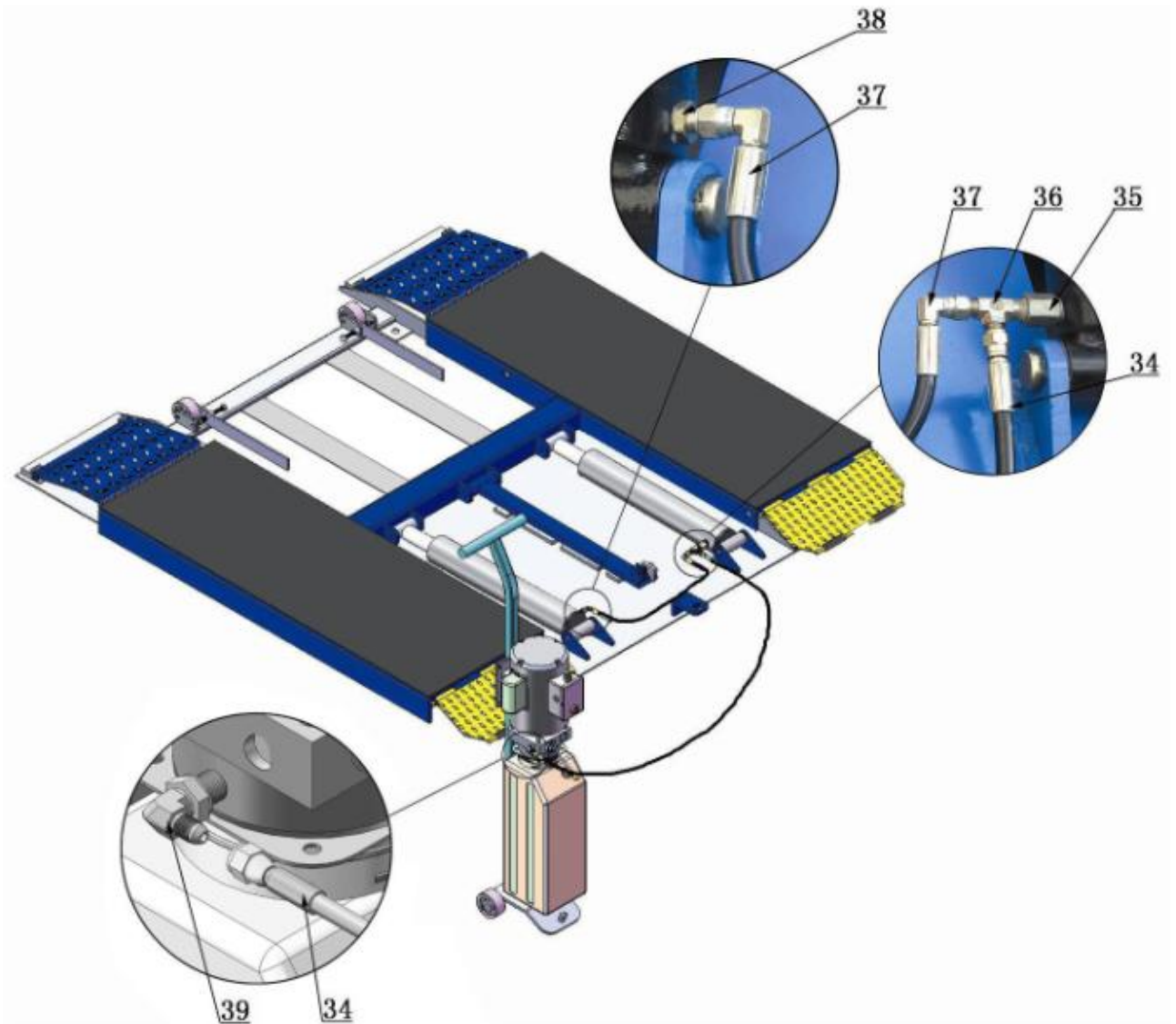

Fig. 7

D. Install electrical system

Connect the power source on the data plate of power unit.

Note: For the safety of operators, the power wiring must contact the earth well.

Single phase motor

1. Circuit diagram (See Fig. 8)

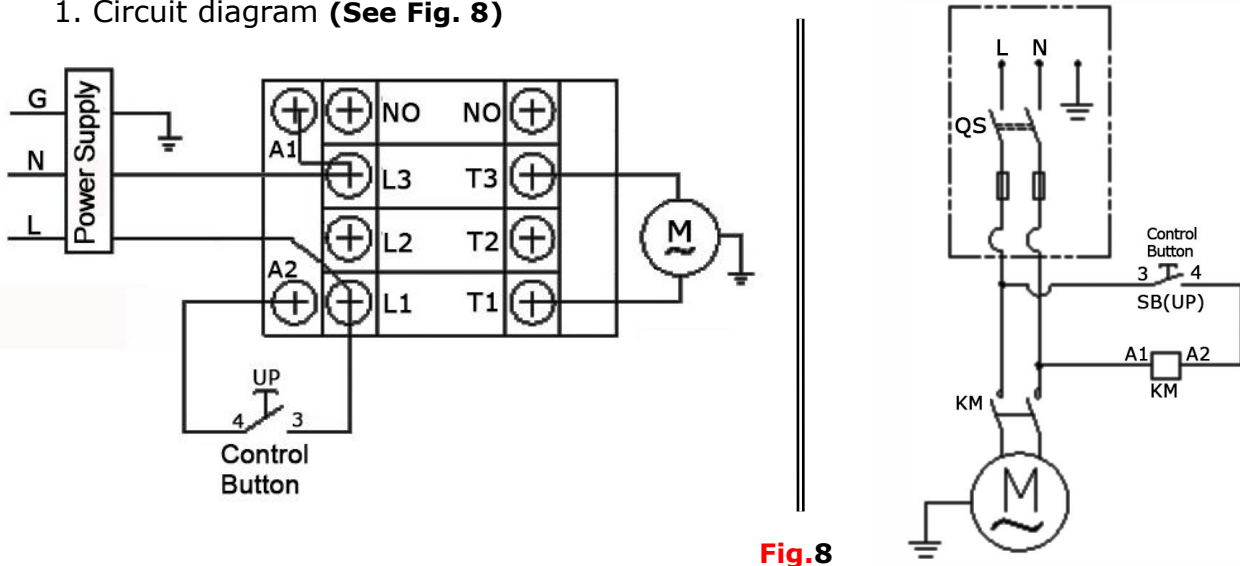

Fig.8

2. Connection step (See Fig. 9)

Connecting the two power supply wires (active wire **L** and neutral wire **N**) to terminals of AC contactor marked L1, L3 respectively. Earth wire(yellow and green wire) is connected with the earth wire terminal of the motor

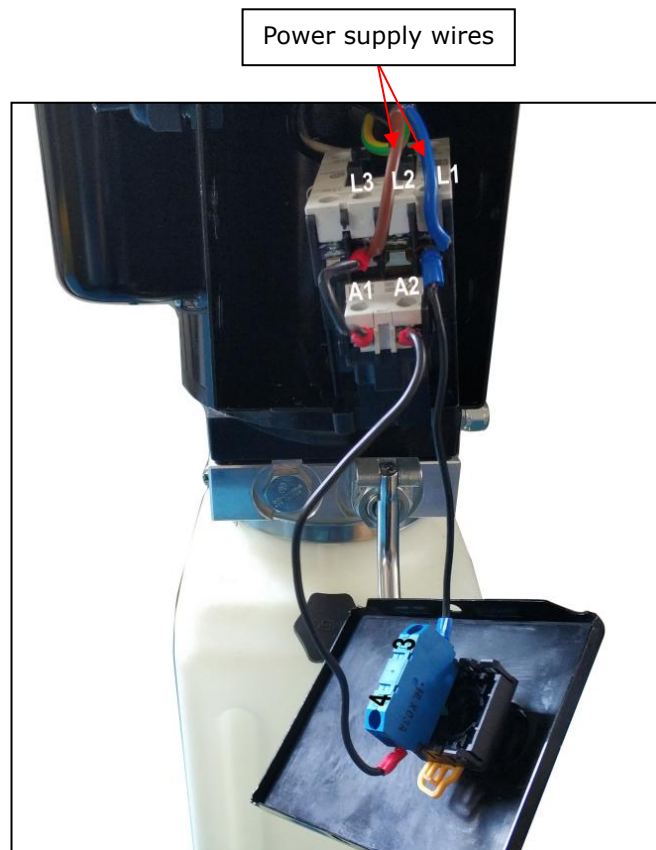
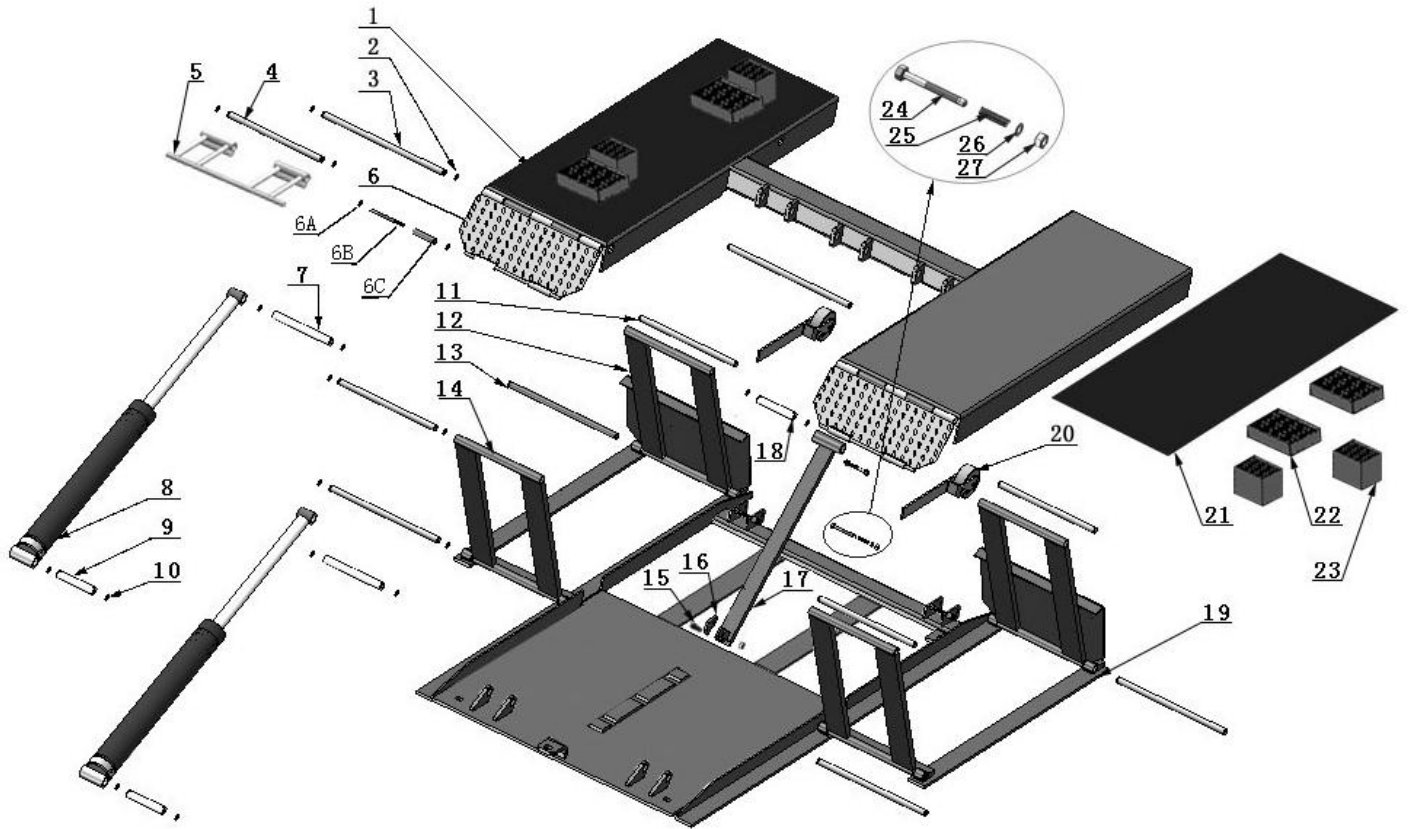

Fig. 9

IV. EXPLODED VIEW

MODEL LR10



Rollers

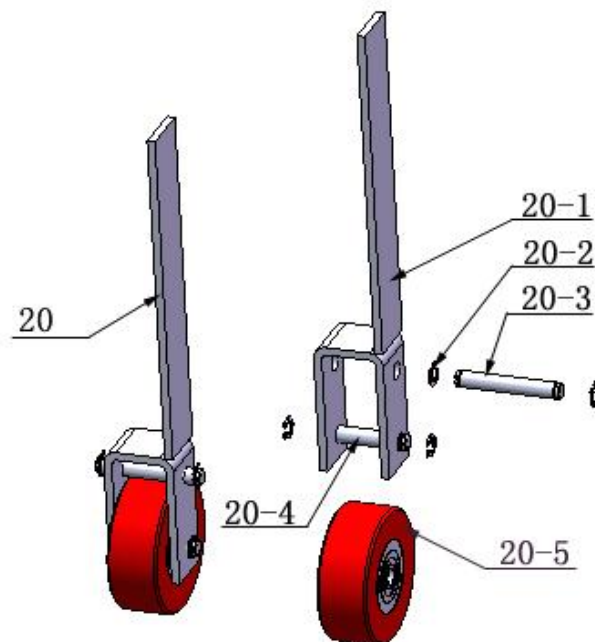

Fig. 10

PARTS LIST FOR MODEL LR10

Item	Part#	Description	QTY.	Note
1	11630001A	Platform	1	
2	10206019	Snap Ring ϕ 19	24	
3	11630003	Pin for drive-in ramp ϕ 19*452	2	
4	11630106	Bracket Pin ϕ 19*410	2	
5	11620006A	Bracket	2	
6	11630108	Drive-in ramp	2	
6A	10209010	Snap Ring ϕ 10	8	
6B	11620043	Roller Pin for drive-in ramp	4	
6C	10620063	Roller for drive-in ramp (black nylon)	4	
7	11630109	Cylinder Connecting pin ϕ 25*92	2	
8	10630006	Cylinder	2	
9	11630007	Cylinder case connecting pin ϕ 25*132	2	
10	10206032	Snap Ring ϕ 25	10	
11	11630008	Frame Support connect pin upper	4	
12	11630009	Frame support (front)	2	
13	11630010	Frame Support connect pin ϕ 19*405	4	
14	11630011	Frame Support	2	
15	10630100	Socket Bolt M10*40	1	
16	11630013	Safety Block	1	
17	11630014	Safety Support	1	
18	11630105	Pin for Safety Support ϕ 25*142	1	
19	11630111	Base	1	
20	11640024	Roller	2	
21	10630102	Rubber Pad 438*1350*5	2	
22	10620034	Rubber Pad 100*120*38	4	
23	10610070	Rubber Pad 100*120*70	4	
24	10420020B	Hex Bolt M10*115	2	
25	10630015	Spring ϕ 15* ϕ 12*55	2	
26	10209022	Washer ϕ 10	2	
27	10209056	Self Locking Nut M10	3	
28	071104	Power Unit	1	
29	10209003	Hex Bolt M8*25	4	
30	10209005	Self Locking Nut M8	4	
31	11640021	Power Unit Stand	1	
32	10206006	Washer ϕ 12	2	
33	10420046	Split Pin ϕ 3*20	2	
34	1003035001	Oil Hose 5/16*3650	1	
35	10630103	Straight Fitting	1	
36	10209062	T fitting	1	
37	10630104	Oil Hose 1/4*550(double 90°)	1	
38	10209064	Straight fitting for cylinder	1	
39	10209060	90 degree fitting for power unit	1	
40	10630501A	Parts Box	1	

Item	Part#	Description	QTY.	Note
Parts for Roller				
20-1	11630031	Rollers handle	2	
20-2	10630032	Snap Ring $\phi 12$	8	
20-3	11630033	Connecting Shaft $\phi 12 \times 80$	2	
20-4	11630034	Roller Shaft $\phi 12 \times 65$	2	
20-5	1003275021	White wheel	4	

Cylinder

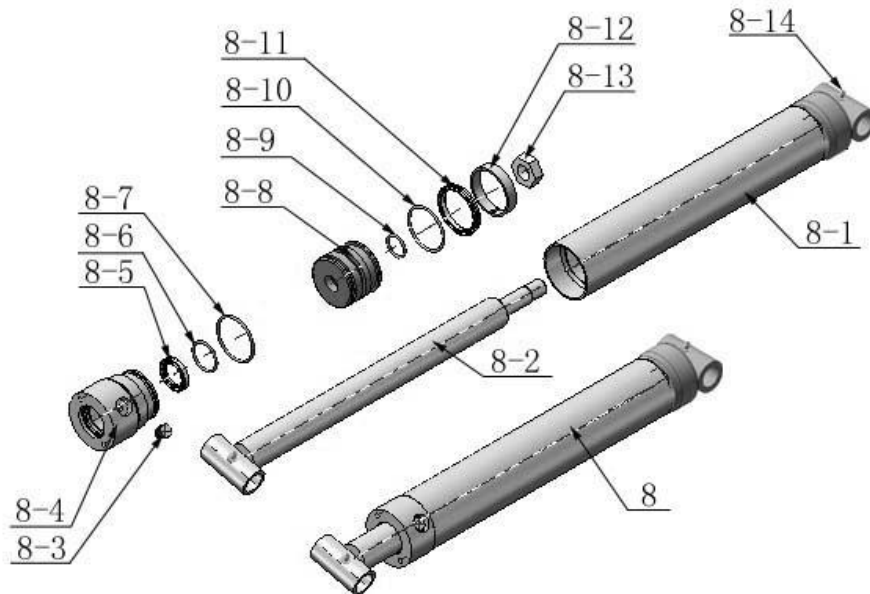

Fig. 11

Item	Part No.	Description	QTY.	Note
8-1	11630029	Bore Weldment	2	
8-2	11630026	Piston Rod	2	
8-3	10201034	Bleeding Plug	2	
8-4	11630030	Head cap	2	
8-5	10209078	Dust ring	2	
8-6	10201035	O-Ring inside head cap	2	
8-7	10620049	O-Ring outside head cap	2	
8-8	11630028	Piston	2	
8-9	10620050	Small O-Ring for piston	2	
8-10	10630027	O-Ring outside piston	2	
8-11	10620054	Y-Ring OSI	2	
8-12	10620055	Support Ring	2	
8-13	10206071	Nut	2	
8-14	10620064	Greasing Fitting	4	

Manual Power Unit (071101)

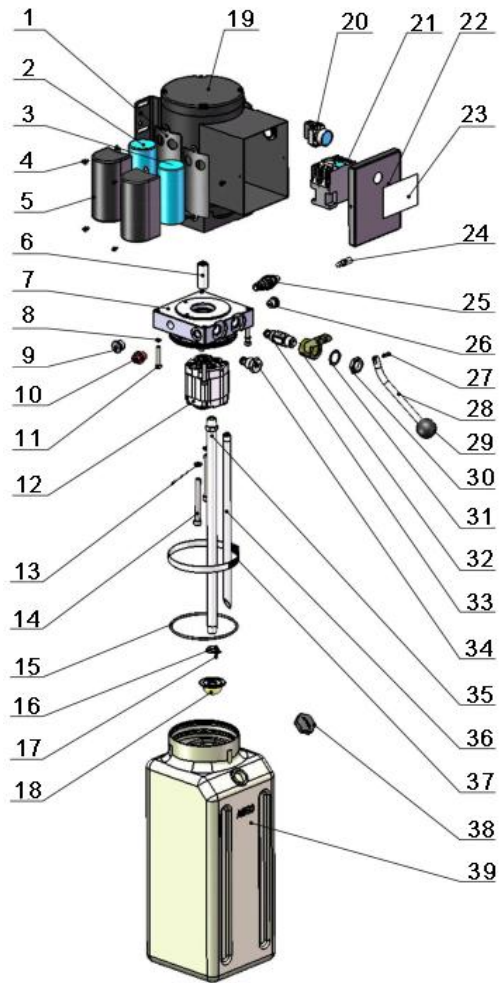

Fig. 12

Manual Power Unit 220V/50/60HZ Single Phase

Item	Part No.	Description	QTY.	Note
1	81400180	Rubber Pad	2	
2	81400250	Starting capacitor	1	
3	81400200	Running capacitor	1	
4	10420148	Cap head bolts with washer	4	
5	81400066	Cover for capacity	2	
6	81400363	Motor Connecting Shaft	1	
7	80101013	Manifold Block	1	
8	10209149	Lock Washer	4	
9	81400276	Plug(socket iron)	1	
10	81400259	Plug(red rubber)	1	
11	85090142	Socket Bolt	4	
12	81400280	Gear pump	1	
13	10209034	Lock Washer	2	
14	81400295	Socket Bolt	2	
15	81400365	O Ring	1	
16	10209152	Belt	1	
17	85090167	Magnet	1	
18	81400290	Filter	1	
19	81400413	Motor	1	
20	10420070	Push Button	1	
21	41030055	AC Contactor	1	
22	81400287	Cover of Motor terminal box	1	
23	71111216	AMGO label	1	
24	81400560	Throttle valve	1	
25	81400266	Relief Valve	1	
26	81400284	Plug	1	
27	10720118	Elastic latch	1	
28	81400451	Release valve handle	1	
29	10209020	Black plastic ball	1	
30	81400421	Release valve Nut	1	
31	81400422	Release valve washer	1	
32	81400449	Release valve seat (low)	1	
33	81400567	Release Valve	1	
34	81400566	Check valve	1	
35	81400288	Oil suction pipe	1	
36	81400289	Oil return pipe	1	
37	81400364	Clamp(stainless steel)	1	
38	81400263	Oil tank cap	1	
39	81400275	Oil tank	1	

Illustration of hydraulic valve for power unit

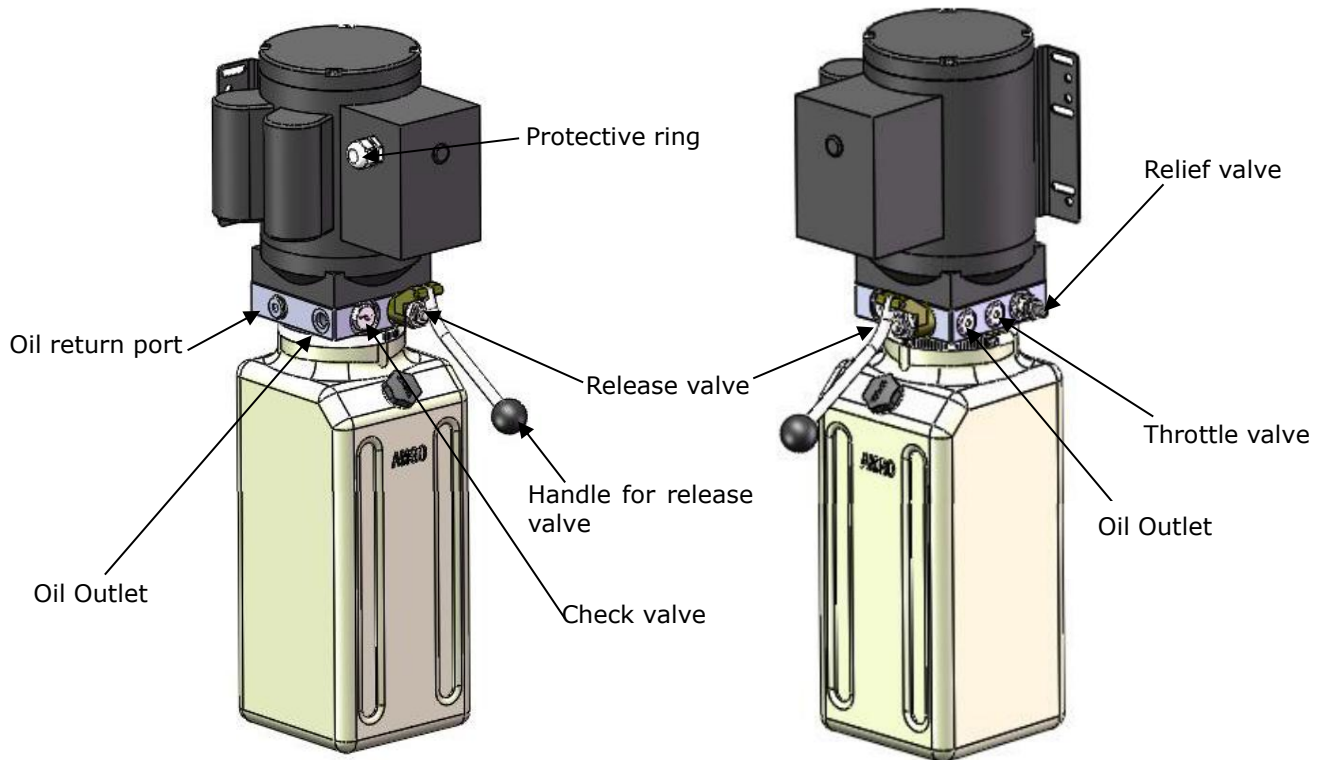

Fig. 13

V. OPERATION INSTRUCTIONS

1. Install the oil hose between oil cylinder and power unit, connect well the power supply wire. The machine can be ready to use.
2. The roller must be disengage when lifting vehicle (**See Fig.16**). To raise and lock the lift: Press the button up till the lift is raised to the required height and the locks are in engaged (**See Fig.14**), then push release handle of the power unit, the lift would be locked.
3. To lower lift: Press the button UP, until the safety lock is in the released position (**See Fig.15**), lower lift by pushing lowering handle.

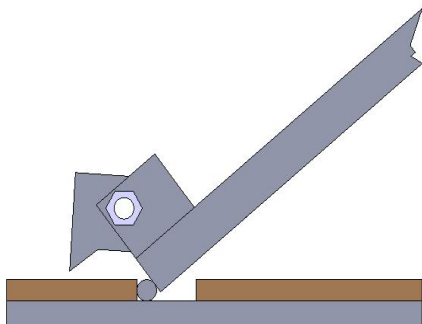

Fig.14

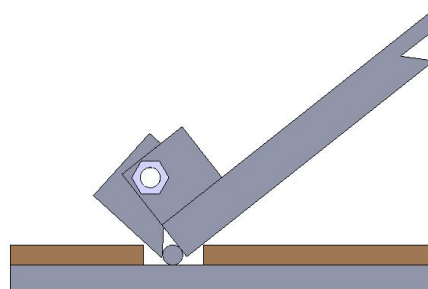

Fig.15

5. Move lift: Pull up roller bracket, lock two roller to the lift with roller shaft. (See Fig. 16& 17). Moving the lift by the power unit stand.

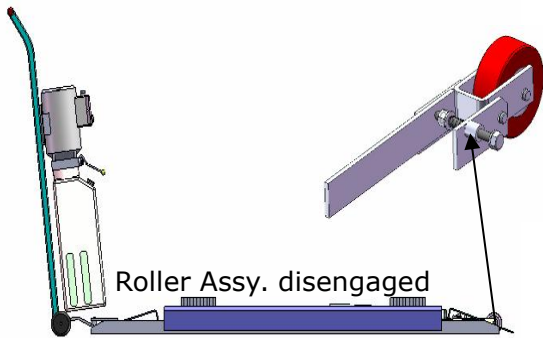

Fig. 16

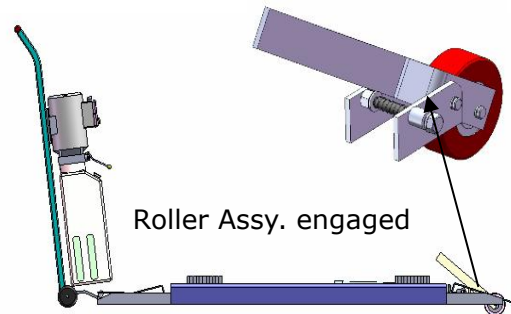

Fig. 17

1. There are four fixed holes in the machine, can fix the machine on ground by 3/4 X 4 3/4" anchor bolts (See Fig.18).

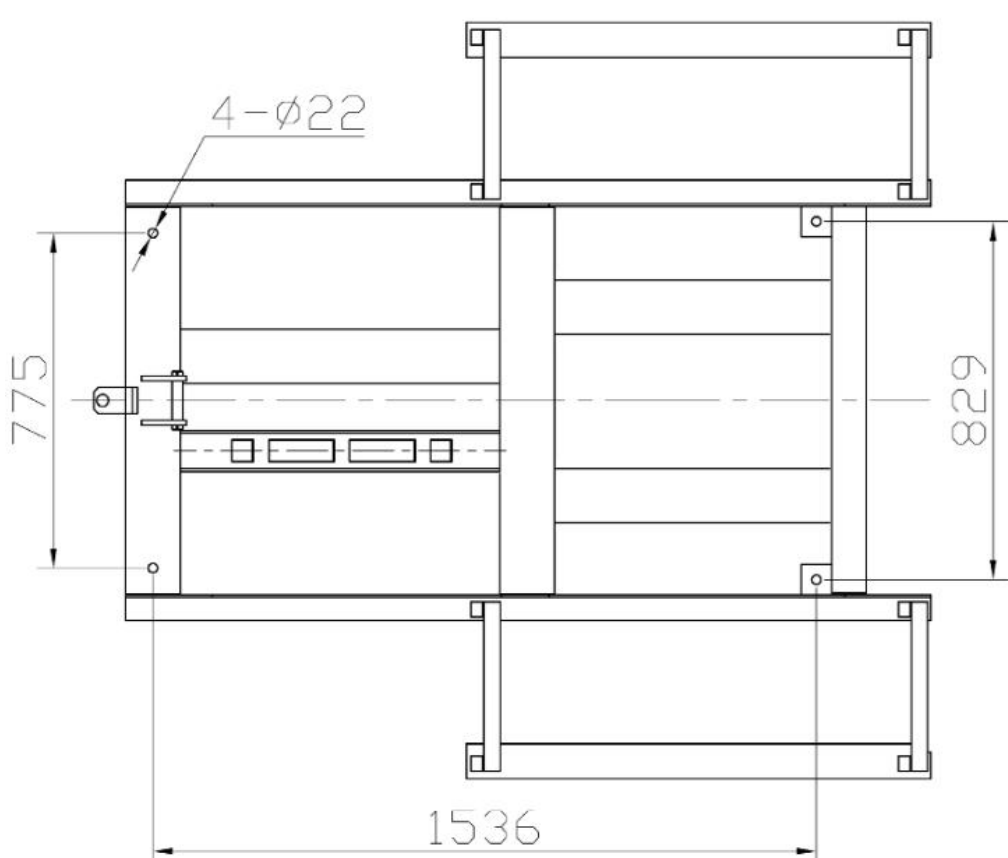

Fig. 18

VI. MAINTENANCE SCHEDULE

Monthly:

1. Lubricate all moving parts with lubricant.
2. Check all connectors, bolts and pins to insure proper mounting.
3. Make a visual inspection of all hydraulic hoses/lines for possible wear or leakage.

Every six months:

1. 1. Make a visual inspection of all moving parts for possible wear, interference or damage.
2. Check all fastener and re-torque.

Oil cylinder maintenance:

In order to extend the service life of the oil cylinder, please operate according to the following requirements.

1. Recommend to use N46 anti-wear hydraulic oil.
2. The hydraulic oil of the lifts should be replaced regularly during using. Replace the hydraulic oil 3 months after the first installation, Replace the hydraulic oil once a year afterwards.
3. Make at least one full trip raising and lowering per day. For exhausting the air from the system, which could effectively avoid the corrosion of the cylinder and damage to the seals caused by presence of air or water in the system.
4. Protect the outer surface of the oil cylinder's piston rod from bumping and scratching, and timely clean up the debris on the oil cylinder dust-ring and the piston rod.

VII. TROUBLE SHOOTING

TROUBLE	CAUSE	REMEDY
Motor does not run	<ol style="list-style-type: none"> 1. Start Button does not work 2. Wiring connections are not in good condition 3. Motor burned out 4. AC contactor burned out 	<ol style="list-style-type: none"> 1. Replace Start button 2. Repair all wiring connections 3. Repair or replace motor 4. Replace AC Contactor
Motor runs but the lift is not raised	<ol style="list-style-type: none"> 1. Motor runs in reverse rotation 2. Gear Pump out of operation 3. Release Valve in damage 4. Relief Valve or Check Valve in damage 5. Low oil level 6. Overload or system low pressure 	<ol style="list-style-type: none"> 1. Reverse two power wire 2. Repair or replace 3. Repair or replace 4. Repair or replace 5. Fill tank 6. Check load or adjusting the pressure of hydraulic system
Lift does not stay up	<ol style="list-style-type: none"> 1. Release Valve out of work 2. Relief Valve or Check Valve leakage 3. Cylinder or Fittings leaks 	Repair or replace
Lift raises slowly	<ol style="list-style-type: none"> 1. Oil line is jammed 2. Motor running on low voltage 3. Oil mixed with air 4. Gear Pump leaks 5. Overload lifting 	<ol style="list-style-type: none"> 1. Clean the oil line 2. Check electrical system 3. Fill tank 4. Repair or replace pump 5. Check load
Lift can not lower	<ol style="list-style-type: none"> 1. Safety device are in activated 2. Release valve in damage 3. Oil system is jammed 	<ol style="list-style-type: none"> 1. Release the safeties 2. Repair or replace 3. Replace Clean the oil system

VIII. Lift disposal.

When the car lift cannot meet the requirements for normal use and needs to be disposed, it should follow local laws and regulations.



AMGO HYDRAULIC CORPORATION

1931 Joe Rogers Blvd, Manning, South Carolina, USA

Tel: (803) 505-6410

Fax: (803) 505-6410

Manual Part No. : 72215801

Revision Date: : 2022/02