

**AMGO**  <sup>®</sup> **Hydraulics**

Original

## Installation And Service Manual



**MID-RISED SCISSORS LIFT**  
**Model: EM06**

# CONTENTS

Product Features and Specifications .....	1
Installation Requirement .....	2
Steps of Installation.....	3
Exploded View .....	8
Operation Instructions .....	15
Maintenance Schedule.....	16
Trouble Shooting.....	17
Lift Disposal.....	17

## I. PRODUCT FEATURES AND SPECIFICATIONS

### MID-RISED MODEL EM06

- Low voltage(24V) electric control system, refinement control cabinet.
- Dual oil circuit design and hydraulic self-lock system
- Dual hydraulic cylinders to make the operation more stable.
- Movable drive-in ramps and extended platforms accommodate varying wheelbase vehicles.
- Stop switch and alarm tone when coming down from 300mm to ground
- Non-skid diamond runway.



**Fig.1**

### MODEL EM06 SPECIFICATIONS

Model	Lifting Capacity	Lifting Time	Raised Height	Lowered Height	Overall Width	Overall Length	Motor
EM06	6,000 lbs	22S	41 3/4"	4 1/8"	80 3/8"	80"	2.0HP

## II. INSTALLATION REQUIREMENT

### A. TOOLS REQUIREMENT

✓ Screw Set



✓ English Spanner (12")



✓ Wrench sets (13#, 15#, 17#, 19# )



✓ Grease Gun



✓ Hook Spanner (40~42mm)



✓ Pliers



Fig. 2

### B. Equipment storage and installation requirements.

The equipment should be stored or installed in a shady, normal temperature, ventilated and dry place.

### C. The equipment should be unload and transfer by forklift.



Fig.3

### D. POWER SUPPLY

The electrical source must be 2.0HP minimum. The source cable size must be 2.5mm<sup>2</sup> and in good condition of contacting with floor.

### III. STEPS OF INSTALLATION

#### A. Location of installation

Check the installation location (concrete, layout, space size etc.) is suitable for lift installation (**See Fig. 4**).

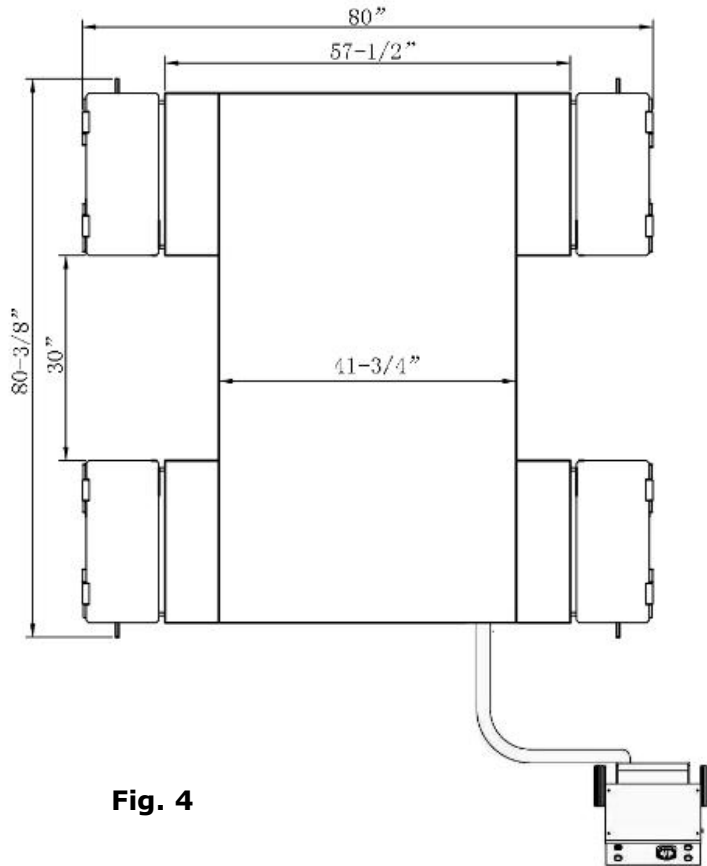
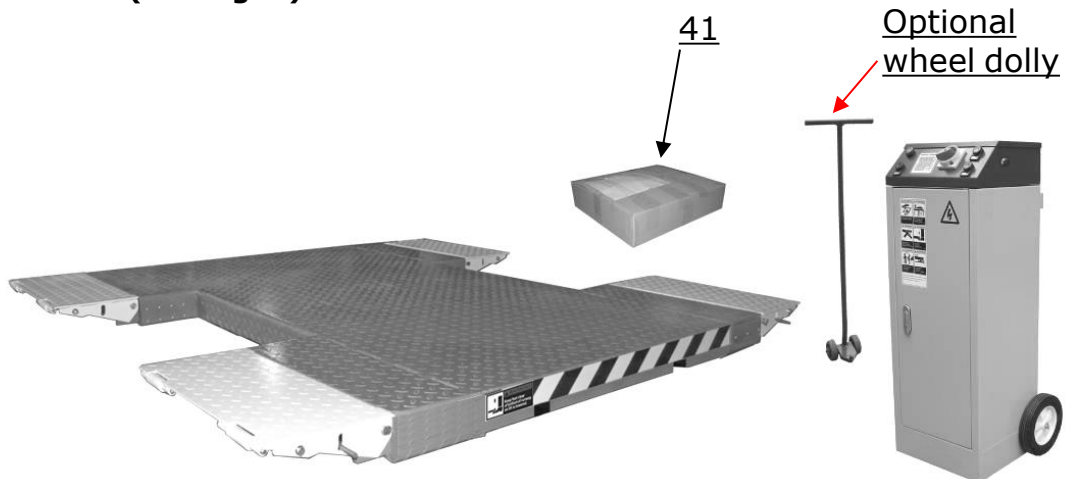

**Fig. 4**

#### B. Check the parts before assembly, make sure all the parts are completed.

1. Packaged lift, Parts box, Control cabinet and the **optional wheel dolly**.

Move the parts aside, open the outer packing and check the parts according to the shipment list (**See Fig. 5**).



**Fig. 5**

2. Open the parts box, check the parts according to the part list (See Fig. 6).



Fig. 6

C. Lay out the lift and control cabinet according to step A and connect oil hoses (See Fig. 7).

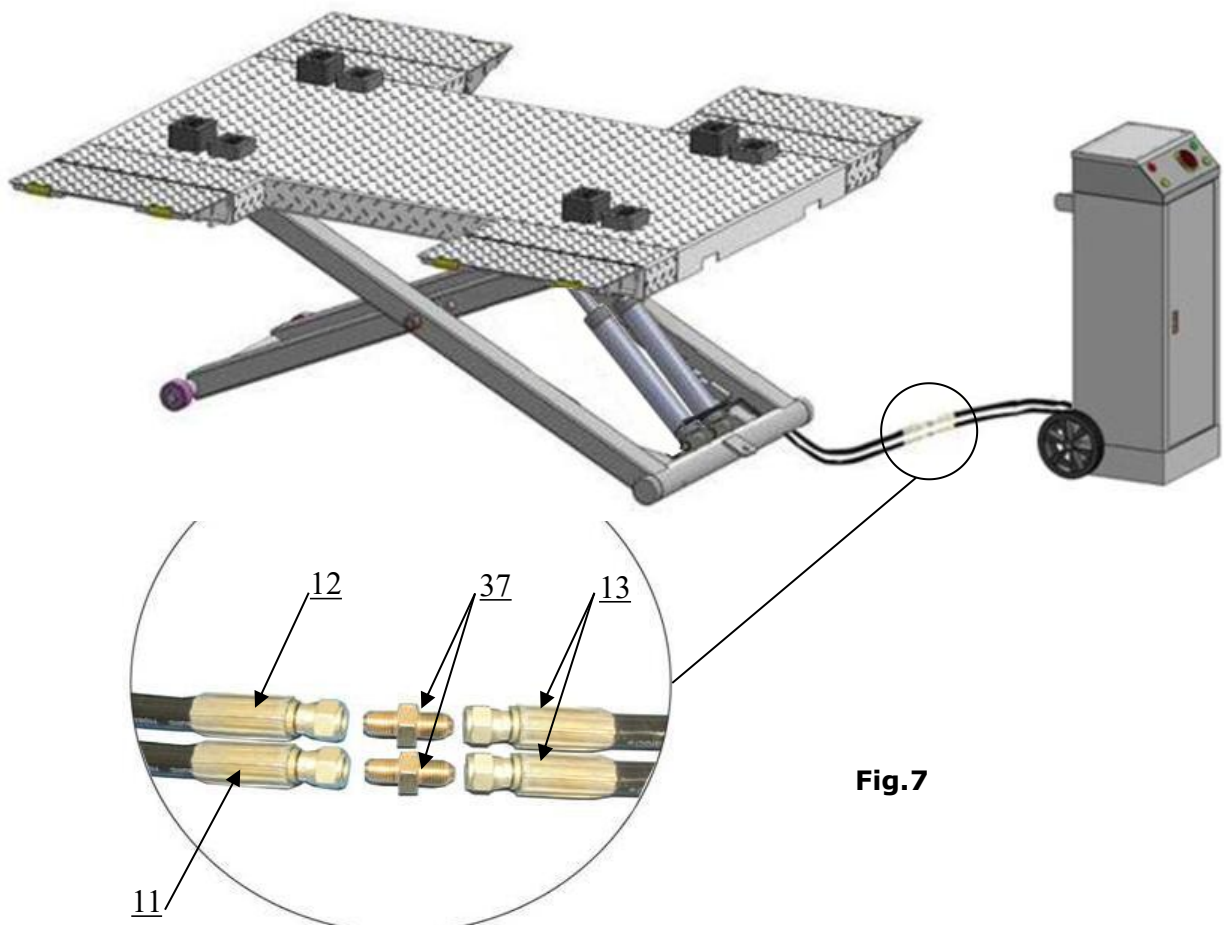
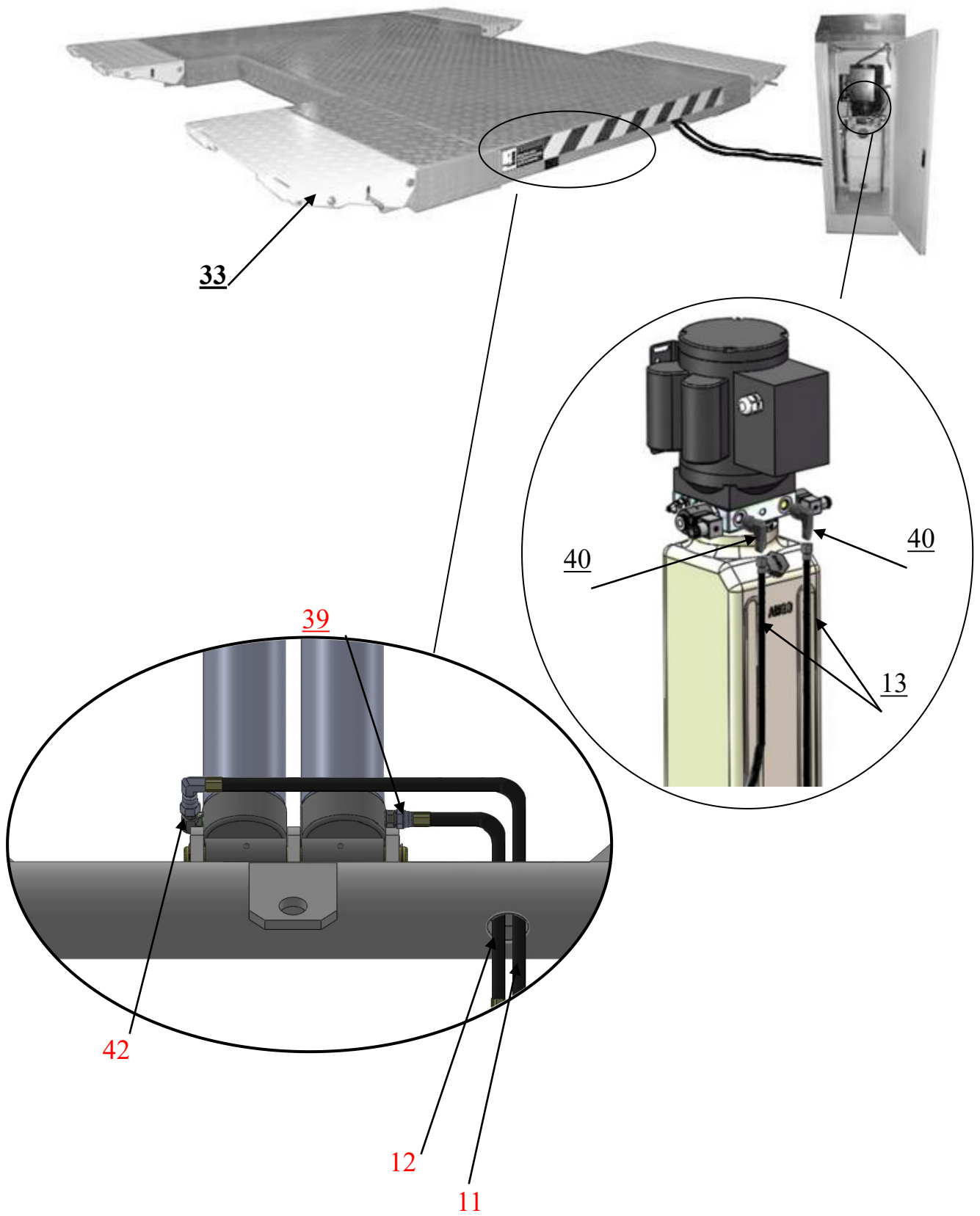

Fig.7

**D. Hydraulic system (See Fig.8)**



**Fig. 8**

## E. Install Circuit System

### 1. 220V Circuit connection

1.1 Connect the power source wire and limit switch according to the Wiring diagram (See Fig.9). When the input power supply are two fire wires, these two fire wires connect terminal L1 and N in separate.

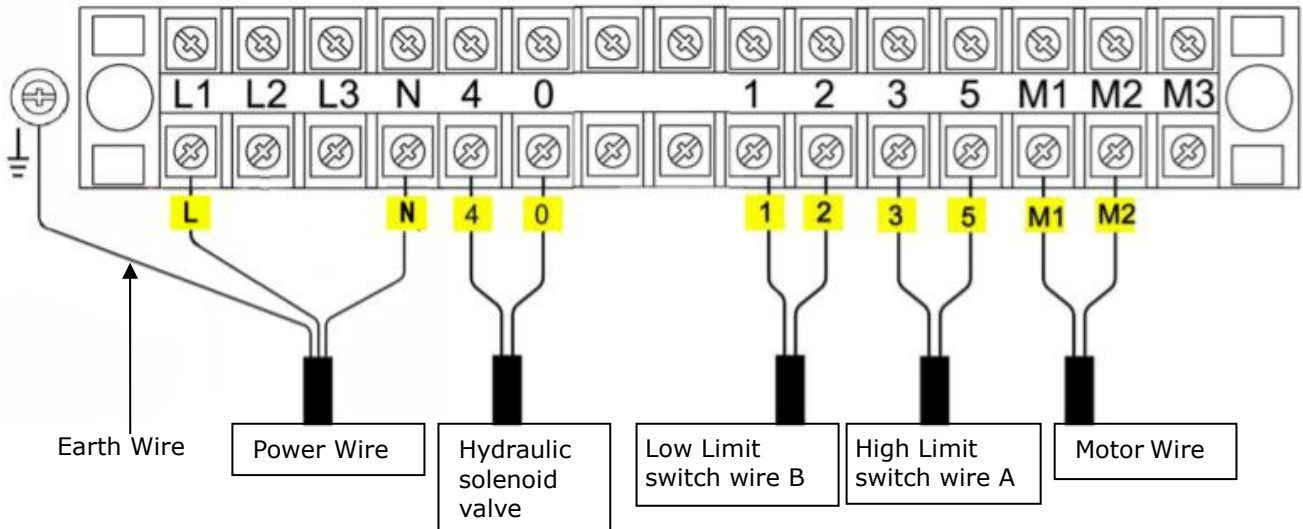

Fig.9

### 1.2 Circuit Diagram (See Fig.10)

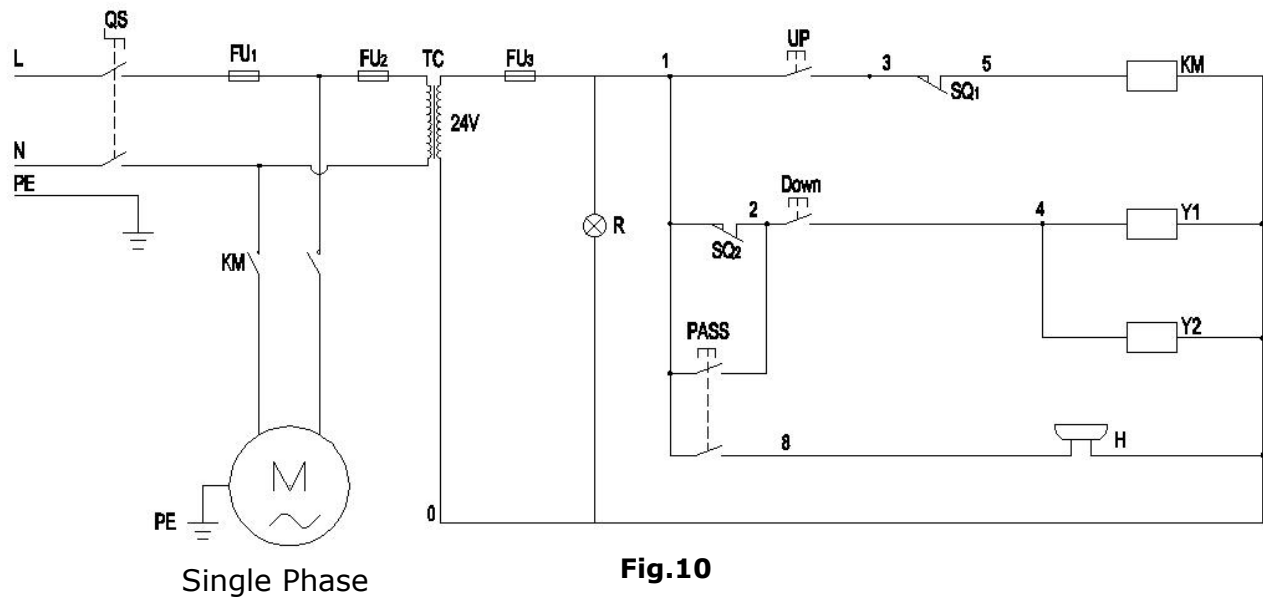

Fig.10

Item	Name	Code	Specification	Item	Name	Code	Specification
1	Power switch	QS	220V AC	8	Hydraulic solenoid valve	Y	AC 24V
2	Breaker	FU <sub>1</sub>	2P	9	Push button	UP	Single
3	Breaker	FU <sub>2</sub>	1P	10	Push button	Down	Single
4	Breaker	FU <sub>3</sub>	1P	11	Push button	Pass	Duplex
5	AC contactor	KM	24V AC	12	Motor	M	Single Phase
6	High Limit switch	SQ <sub>1</sub>	10A	13	Transformer	TC	24V AC
7	Low Limit switch	SQ <sub>2</sub>	10A	14	Power indicator	R	24V AC



2. Electric Component  
2. Limit switch installation illustration

2.1 Higher limit switch illustration (See Fig.11)

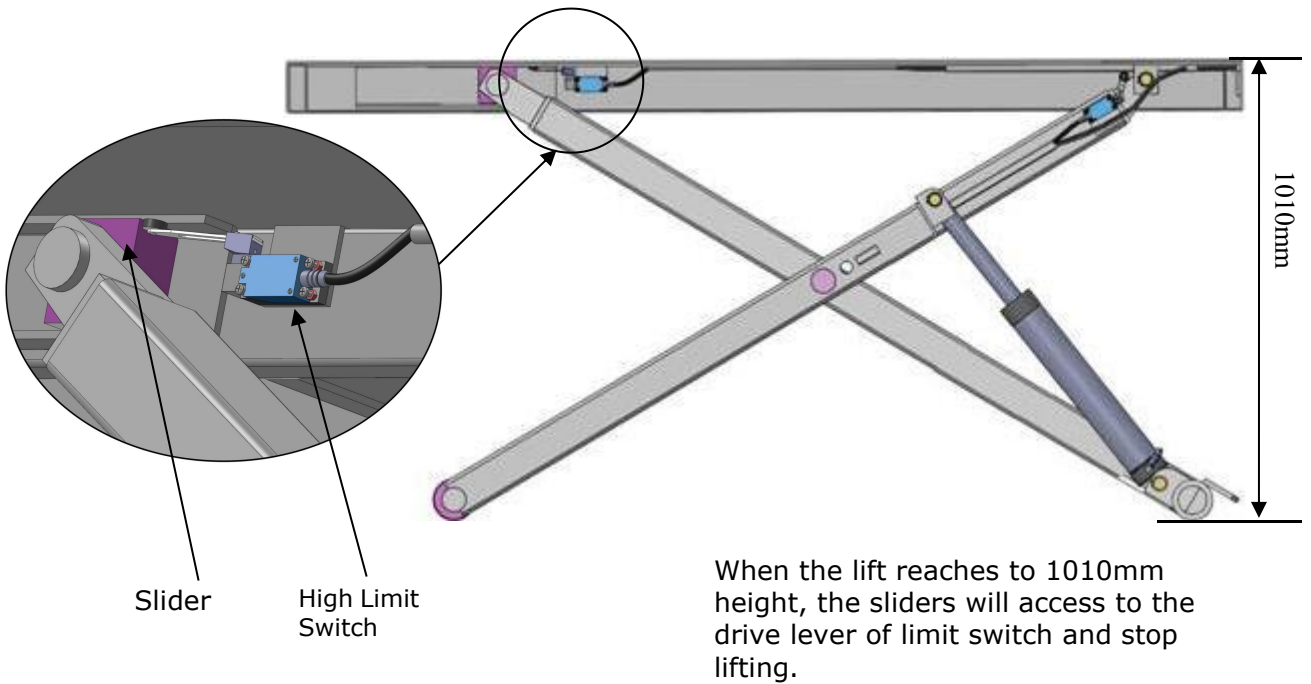

Fig.11

2.2 Lower alarm device instruction (See Fig.12)

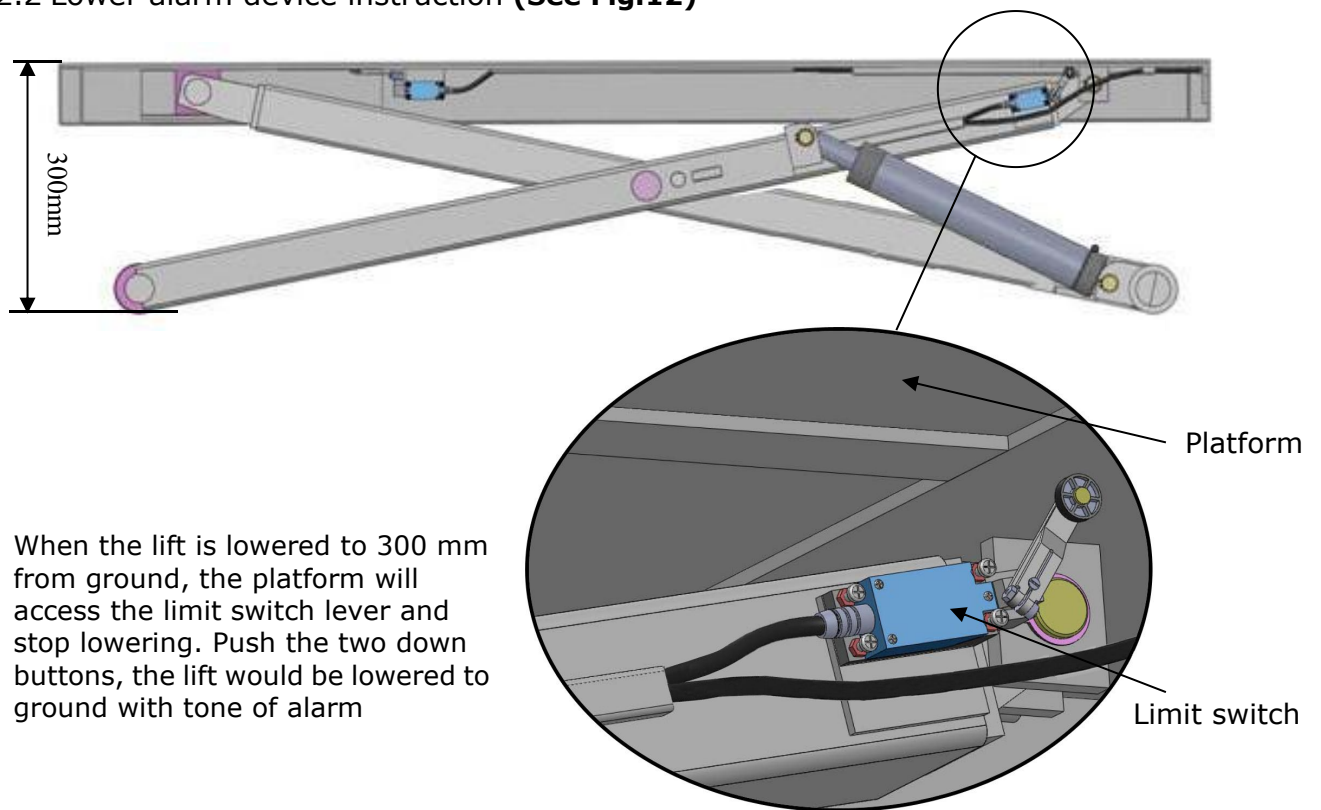

Fig.12

# IV. EXPLODED VIEW

## Model EM06

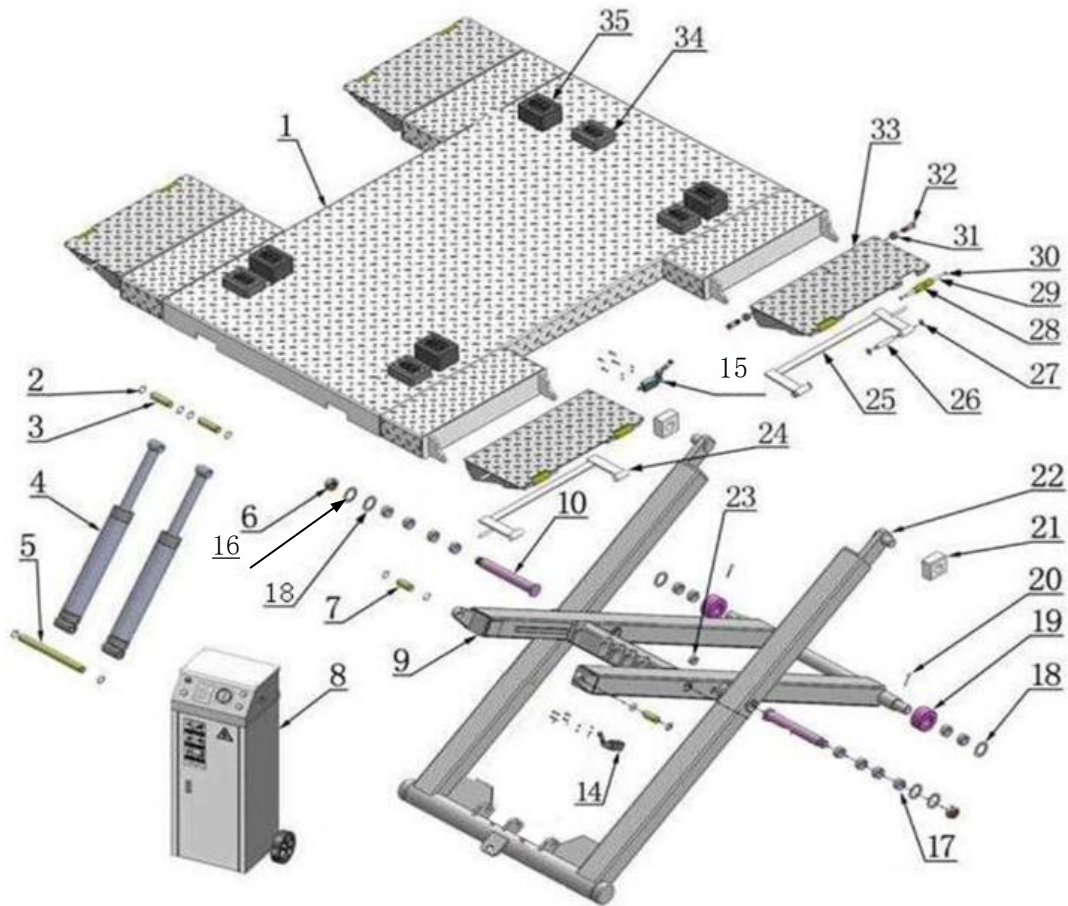

Fig.13

## PARTS LIST FOR EM06

Item	Part#	Description	QTY.	Note
1	11650001	Platform	1	
2	10206032	Snap Ring $\phi 25$	12	
3	11640006A	Connecting Shaft for Cylinder	2	
4	10640116	Cylinder	2	
5	11650049	Cylinder Base Pin	1	
6	10610019	Self-locking Nut M30*3.5	2	
6A	10610108	Washer $\phi 44 * \phi 30.5 * 2$	2	
7	11650003	Inner Scissor Pin	2	
8	10650048	Control Cabinet	1	
9	11640016	Inner Scissors	1	
10	11650018	Scissors Pin	2	
11	10650050	Oil hose 1/4"*740mm	1	
12	1086010280	Oil hose 1/4"*500mm	1	
13	1003095002	Oil hose 1/4"*3000mm	2	
14	10650029	Lower Limit Switch Assy.	1	
15	10650028	Higher Limit Switch Assy.	1	
16	10650026	Washer $\phi 60 * \phi 36 * 3$	2	
17	10420132A	Bronze Bush for Pulley $\phi 41.3 * \phi 35.1 * 20$	12	
18	10420023A	Washer $\phi 36 * \phi 65 * 3$	2	
19	11640022	Roller	2	
20	10201005	Split Pin $\phi 4 * 50$	2	
21	10610003A	Slider Block	2	
22	11640017A	Outer Scissor	1	
23	10420156	Protecting Rubber Ring $\phi 24$	5	
24	11620130	Support Bracket(right)	2	
26	11620123	Bracket Shaft $\phi 16 * 90$	8	
27	10420037	Snap Ring $\phi 16$	16	
28	10610667	Roller for Drive-in Ramp	8	
29	11620043	Roller shaft for drive in ramp	8	
30	10209010	Snap Ring $\phi 10$	16	
31	10650024	Self-locking Nut M16	8	
32	11620124	Pin for Drive-in Ramp	8	
33	11620128	Drive-in Ramp	4	
34	10620034	Rubber Pad 120*100*38	4	
35	10610070	Rubber Pad 120*100*70	4	
36	10650008	Oil Hose sleeve $\phi 25 * 3000$	1	
37	10620079	Straight Fitting 1/4JIC(M) *1/4JIC(M)	2	

Item	Part#	Description	QTY.	Note
38	10650010	Wheel dolly assy.(optional)	1	
39	10209064	Straight Fitting for cylinder 1/4JIC(M)*1/4NPT(M)	1	
40	10209060	90° Fitting for Power Unit	2	
41	10650501	Parts Box	1	
42	10420097	90° Fitting 1/4NPT(M)*1/4JIC(M)	1	
43	10201108	Fitting	1	
200	071203	Power Unit	1	

## CONTROL CABINET

Part #: 10650048 (Single Phase)

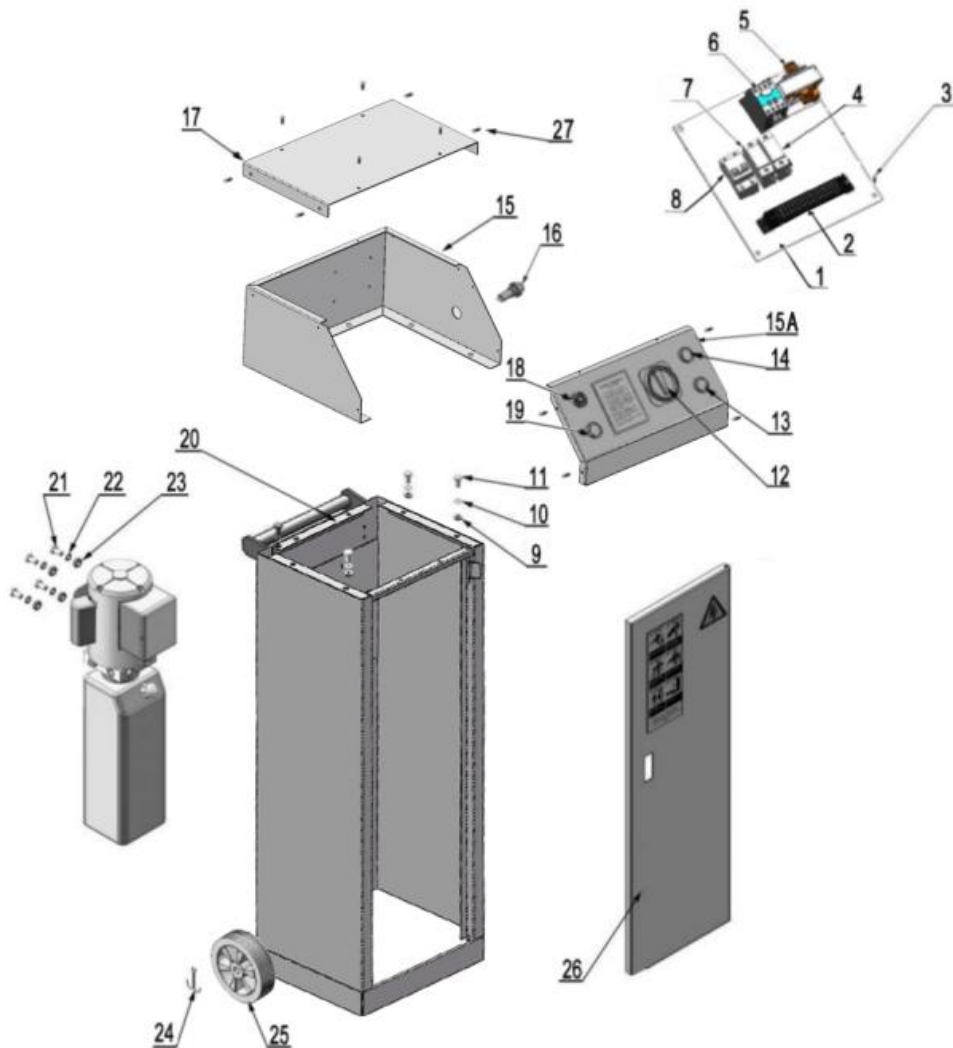
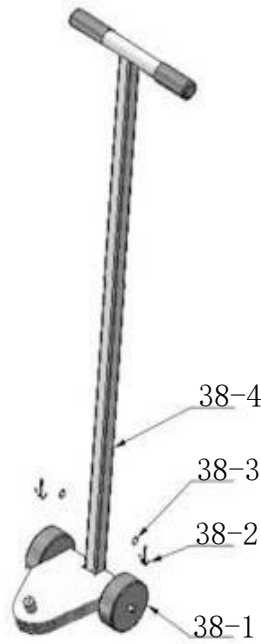

Fig.14

<b>Parts for Control Cabinet</b>				
<b>Item</b>	<b>Part#</b>	<b>Description</b>	<b>QTY.</b>	<b>Note</b>
1	11650651	Terminal Blocks	1	
2	10620082	Panel for Installing Element	1	
3	1061K052	Cup head screw	15	
4	10202049	Breaker 1P	1	
5	10420134	24V AC Contractor (KM)	1	
6	10420084A	24V Transformer (TC)	1	
7	10202049	Breaker 1P	1	
8	10202046	Fuse 2P (Single Phase only)	1	
9	10217011	Hex nut M6	4	
10	10420045	φ 6Washer	4	
11	1061K108	Hex bolt M6*12	4	
12	41010217	Power Switch (QS)	1	
13	10201094	Indicator lamp	1	
14	10420070	Button (UP)	1	
15	11650660	Upper box	1	
15A	11650654	Control Panel	1	
16	10420142	Button (PASS)	1	
17	11650653	Cabinet cover	1	
18	10420143	Buzzer	1	
19	10420070	Button (DOWN)	1	
20	11650665	Cabinet box	1	
21	1061K050	Hex Bolt M8*30	4	
22	10209033	φ 8Washer	4	
23	10209005	Self-locking nut M8	4	
24	1061K104	Split pin 3*30	2	
25	1061K102	Roller φ 150* φ 12*3	2	
26	11650666	Cabinet door	1	
27	10420153	Cup head screw M6*20	12	

**WHEEL DOLLY (Optional)**



**Fig. 15**

**CYLINDER**

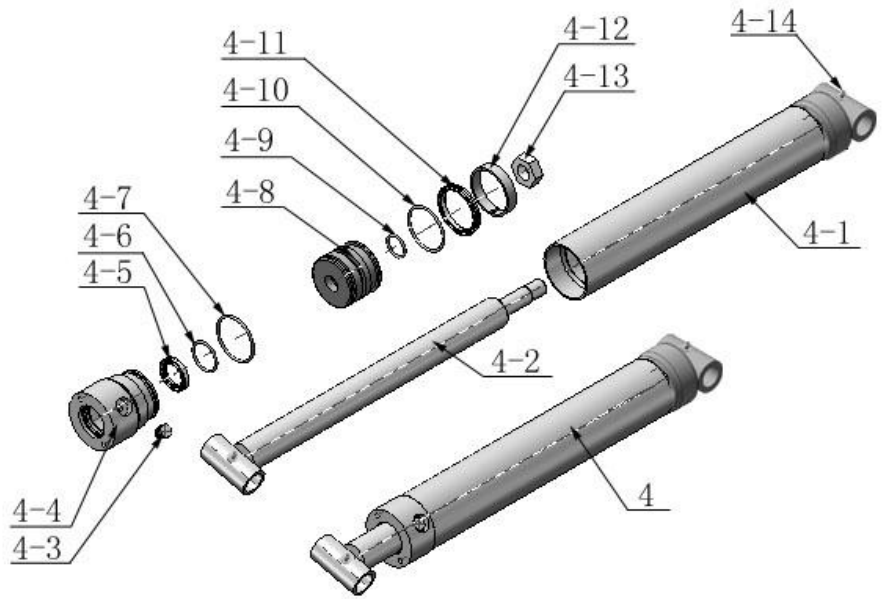

**Fig.16**

<b>PARTS FOR CYLINDER</b>				
<b>Item</b>	<b>Part#</b>	<b>Description</b>	<b>QTY.</b>	<b>Note</b>
4-1	11640657	Bore Weldment	2	
4-2	11640031A	Piston Rod	2	
4-3	10201034	Bleeding Plug	2	
4-4	11203083	Head cap	2	
4-5	10209078	Dust ring	2	
4-6	10201032	O-Ring inside head cap	2	
4-7	10203084	O-Ring outside head cap	2	
4-8	11203079	Piston	2	
4-9	10206069	Small O-Ring for Piston	2	
4-10	10203082	O-Ring outside piston	2	
4-11	10410087	Y-Ring OSI	2	
4-12	10410086	Support Ring	2	
4-13	10206071	Nut	2	
4-14	10620064	Greasing Fitting	4	
<b>PARTS FOR OPTIONAL WHEEL DOLLY</b>				
38-1	1003275021	White wheel	2	
38-2	10420046	Split Pin $\phi 3 \times 20$	2	
38-3	10206006	Washer $\phi 12$	2	
38-4	11650012	Power unit Stand	1	

# ELECTRIC POWER UNIT (071203)

220V, 60HZ/1 Phase

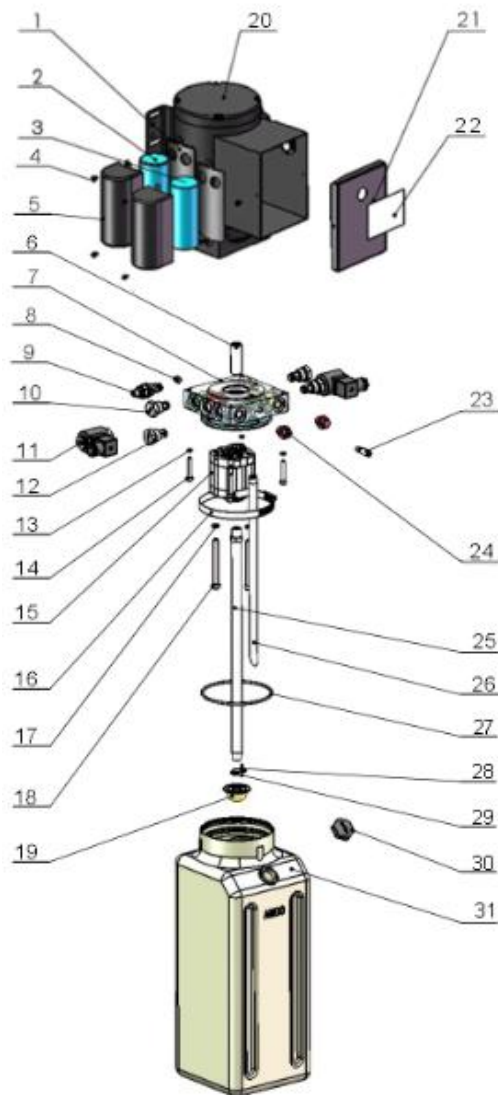

Fig. 17

<b>Parts for Electric Power Unit 220V/60Hz/1 Phase</b>				
1	81400180	Rubber pad	2	
2	81400250	Start capacitor	1	
3	81400200	Running capacitor	1	
4	10420148	Cap head screw with washer	6	
5	81400066	Cover of capacitor	2	
6	81400363	Motor connecting shaft	1	
7	80101015	Manifold block	1	
8	81400333	Socket plug	4	
9	81400266	Relief valve	1	
10	81400566	Check valve	2	
11	81400420	Solenoid valve coil	2	
12	81400423	Electric pressure relief valve	2	
13	10209149	Washer $\phi 6$	4	
14	85090142	Socket bolt	4	
15	81400280	Gear pump	1	
16	81400364	Clamp (stainless steel)	1	
17	10209034	Lock washer $\phi 8$	2	
18	81400295	Socket bolt	2	
19	81400290	Filter	1	
20	81400590	Motor	1	
21	81400287	Cover of Motor Terminal Box	1	
22	71111231	AMGO Label	1	
23	81400560	Throttle valve	1	
24	81400259	Red plastic plug	2	
25	81400288	Oil Inlet Pipe	1	
26	81400289	Oil Return Pipe	1	
27	81400365	O-ring	1	
28	10209152	Ties	1	
29	85090167	Magnet	1	
30	81400263	Oil tank Cap	1	
31	81400275	Oil tank	1	



## AMGO Electric power unit valve illustration

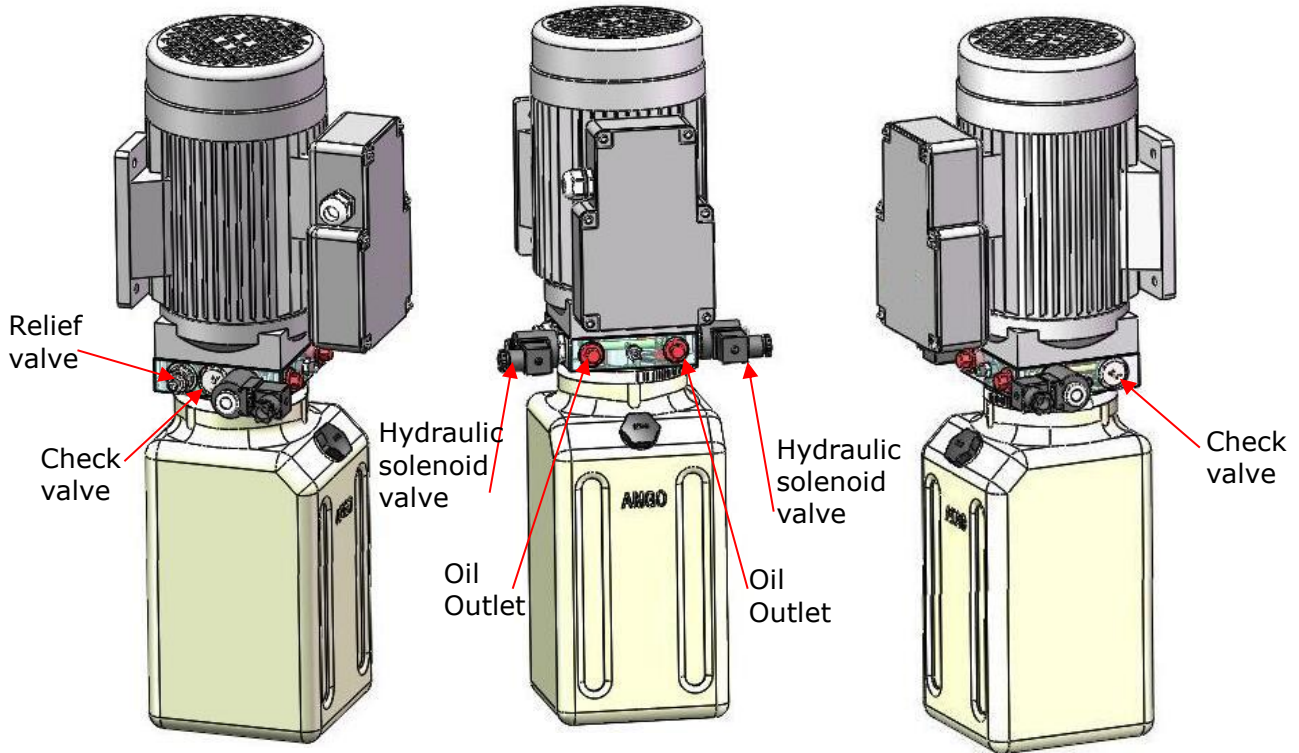

Fig. 18

## V. OPERATION INSTRUCTIONS

1. Install the oil hoses between oil cylinders and power unit, connect the power wire.  
The machine can be ready to use.
2. Drive the vehicle on the platform, select the suitable rubber pad.
3. To lower lift  
Clean the obstacles around and under the lift, ensure people in safety area.  
Press the **DOWN** button to lower the lift.
4. Move the lift: Raise or lower the lift from 200mm to the ground, use the optional wheel dolly to move (**See Fig.19**)

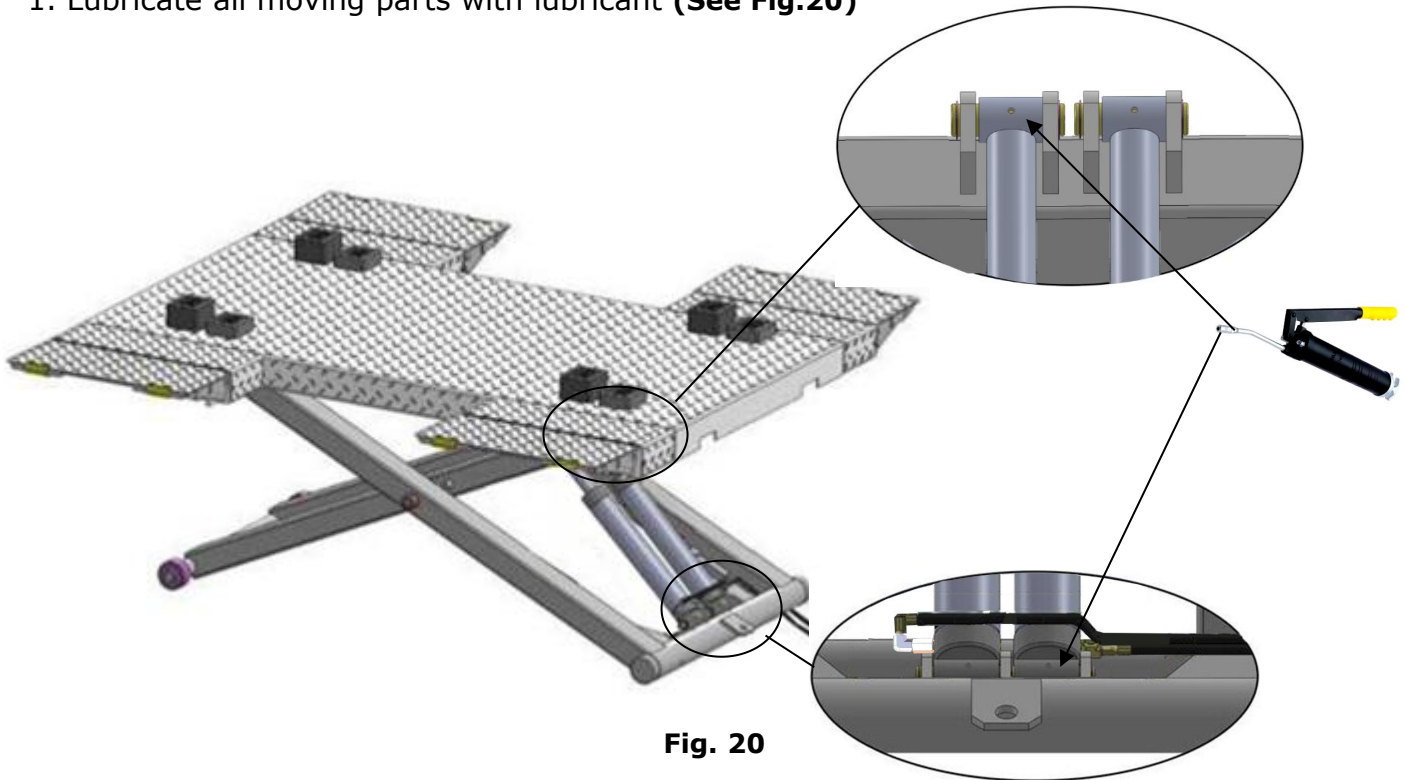

Fig. 19

## VI. MAINTENANCE SCHEDULE

### Monthly

1. Lubricate all moving parts with lubricant (**See Fig.20**)



2. Check all connectors, bolts and pins to insure proper mounting.
3. Make a visual inspection of all hydraulic hoses/lines for possible wear or leakage.

### Every six months

1. Make a visual inspection of all moving parts for possible wear, interference or damage.
2. Check all fastener and re-torque.

### Oil cylinder maintenance:

In order to extend the service life of the oil cylinder, please operate according to the following requirements.

1. Recommend to use N46 anti-wear hydraulic oil.
2. The hydraulic oil of the lifts should be replaced regularly during using. Replace the hydraulic oil 3 months after the first installation, Replace the hydraulic oil once a year afterwards.
3. Make at least one full trip raising and lowering per day. For exhausting the air from the system, which could effectively avoid the corrosion of the cylinder and damage to the seals caused by presence of air or water in the system.

4. Protect the outer surface of the oil cylinder's piston rod from bumping and scratching, and timely clean up the debris on the oil cylinder dust-ring and the piston rod.

## VII. TROUBLE SHOOTING

<b>TROUBLE</b>	<b>CAUSE</b>	<b>REMEDY</b>
Motor does not run	<ol style="list-style-type: none"> <li>1. Button does not work</li> <li>2. Wiring connections are not in good condition</li> <li>3. Motor burned out</li> <li>4. Safety Switch is damaged</li> <li>5. AC contactor burned out</li> </ol>	<ol style="list-style-type: none"> <li>1. Replace button</li> <li>2. Repair all wiring connections</li> <li>3. Repair or replace motor</li> <li>4. Replace the Safety Switch</li> <li>5. Replace AC Contactor</li> </ol>
Motor runs but the lift is not raised	<ol style="list-style-type: none"> <li>1. Motor runs in reverse rotation</li> <li>2. Gear Pump out of operation</li> <li>3. Relief Valve or Check Valve in damage</li> <li>4. Low oil level</li> <li>5. Overload lifting or low pressure</li> </ol>	<ol style="list-style-type: none"> <li>1. Reverse two power wire</li> <li>2. Repair or replace</li> <li>3. Repair or replace</li> <li>4. Fill tank</li> <li>5. Check load or adjust the pressure</li> </ol>
Lift does not stay up	<ol style="list-style-type: none"> <li>1. Release Valve out of work</li> <li>2. Relief Valve or Check Valve leakage</li> <li>3. Cylinder or Fittings leaks</li> </ol>	Repair or replace
Lift raises slowly	<ol style="list-style-type: none"> <li>1. Oil line is jammed</li> <li>2. Motor running on low voltage</li> <li>3. Oil mixed with air</li> <li>4. Gear Pump leaks</li> <li>5. Overload lifting</li> </ol>	<ol style="list-style-type: none"> <li>1. Clean the oil line</li> <li>2. Check Electrical System</li> <li>3. Fill tank</li> <li>4. Repair or replace</li> <li>5. Check load</li> </ol>
Lift cannot lower	<ol style="list-style-type: none"> <li>1. Safety device are in activated</li> <li>2. Release Valve in damage</li> <li>3. Oil system is jammed</li> </ol>	<ol style="list-style-type: none"> <li>1. Release the safeties</li> <li>2. Repair or replace</li> <li>3. Clean the oil system</li> </ol>

## VIII. Lift disposal

When the car lift cannot meet the requirements for normal use and needs to be disposed, it should follow local laws and regulations.



## **AMGO HYDRAULIC CORPORATION**

1931 Jo Rogers Blvd, Manning, South Carolina, USA

Tel: (803) 505-6410

Fax: (803) 505-6410

**Manual Part No.: 72215403**

**Revision Date: 2022/05**