

SINGLE POST PARKING LIFT

The SPL-6 commercial-grade parking lift has been newly improved, with a more sturdy and stable structure. It incorporates AMGO's advanced technologies for space-saving and easy operation, making SPL-6 an ideal parking solution for both home garages and commercial shops.



SPL-6

Main Features

- ✓ Lifting capacity: 6000lbs.
- ✓ Commercial grade, suitable for both commercial applications and home garages.
- ✓ Space saving design, available for low ceiling garage as low as 110".
- ✓ Dual safety devices, single-point release lock, no need air source.
- ✓ H-shaped non slip lifting platform with reinforced column and base to provide excellent stability.
- ✓ The two platforms can be interchangeably installed.
- ✓ Guide ramp is equipped as standard for convenient parking underneath.
- ✓ Exclusive: Foldable drive-on ramps come as standard.



ETL certified AMGO power unit .



Dual safety devices, single-point manual release, only available at AMGO.



Optional rubber wheel chock (1PC), P/N: 40811



Optional plastic oil tray (1set, 4pcs), Kits No. 40807

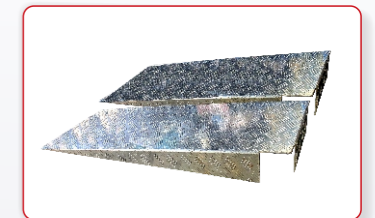

Optional aluminum alloy drive-in ramp (1PC), P/N: 40805

SPECIFICATIONS

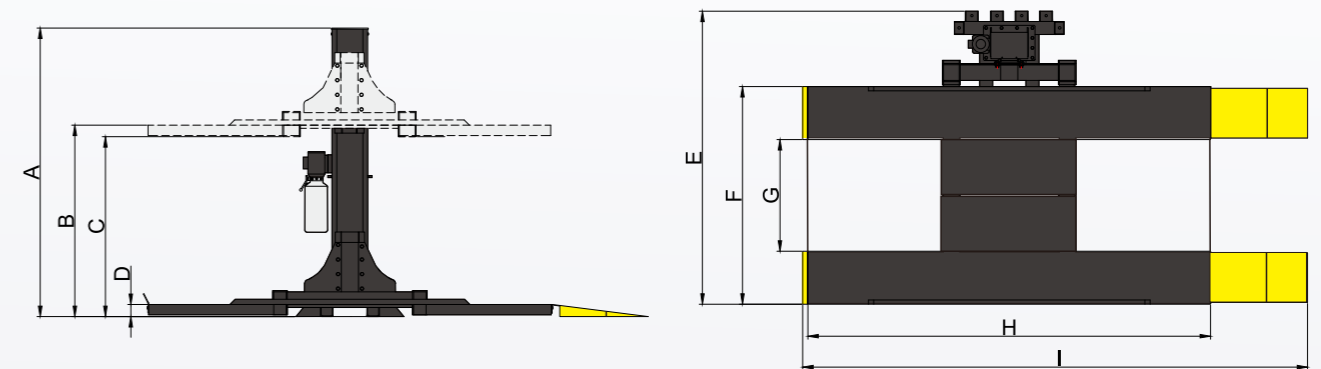

Model	Lifting Capacity	Lifting Time	A		B		C		D	E	F	G	H	I	Gross Weight	Motor
			Overall Height	Max. Lifting Height	Max. lock height to top of runway	Max. height underneath runway	Max. lock height underneath runway	Minimum Height								
SPL-6	6000lbs	84S 32S	108 7/8"	74"	70 3/16"	69 1/4"	65 1/2"	6 1/4"	111"	82 7/16"	42 7/16"	152"	192 1/8"	2,787 lbs	1.0HP/110V 2.0HP/220V	

AMGO HYDRAULIC CORPORATION

SC Division: 1931 Joe Rogers Jr Blvd, Manning, SC 29102, USA

Tel:(803)505-6410

TX Division: 4310 Adler, Suite #200, Dallas, TX 75211, USA

Tel:(214)377-7742