

Installation And Service Manual

CHAIN-DRIVED TWO POST LIFT

Model: BP-12

Cargo Claims

If there is any missing or damaged product during transportation, the buyer must notate on the shipping paperwork or refuse the shipment. NOTATE ALL DAMAGE OR REFUSE DAMAGED SHIPMENT!




DANGER

Read the entire contents of this manual before using this product. Failure to follow instructions and safety precautions could result in serious injury or even death. Make sure all other operators also read this manual. Keep this manual near the machine so that it can be seen by all users. By proceeding with installation and operation, you agree that you are fully understand the contents of this manual and take full responsibility for the use of the product.

CONTENTS

PROFILE	1
IMPORTANT SAFETY INSTRUCTIONS	3
I. PRODUCT FEATURES AND SPECIFICATIONS	5
II. INSTALLATION REQUIREMENT	7
III. INSTALLATION STEPS	9
IV. EXPLODED VIEW	26
V. TEST RUN	32
VI. OPERATION INSTRUCTIONS	34
VII. MAINTENANCE SCHEDULE	35
VIII. TROUBLE SHOOTING	36
IX. CAR LIFT SAFETY TIPS	37
X. LIFT DISPOSAL	37

Explanation of the safety warning symbols used in this manual

 DANGER	Risk of death or injury
 WARNING	Dangerous or unsafe practices that may result in death or injury
 CAUTION	Dangerous or unsafe practices that may result in personal injury, product damage or property damage
ATTENTION	Conditions that may result in damage to products or property

PROFILE

The two post lift is a commonly used vehicle repair and maintenance tool that uses a pneumatic hydraulic or electric system that can lift the car up to a certain height so that the vehicle can be placed in a suitable position for inspection and repair. Car lifts can be divided into pneumatic and electric, which have the characteristics of safe and reliable, simple structure and quick installation.

This instruction manual is specially prepared for you. Your new lift is the product of over a decade of continuous research, testing and development and is the most technologically advanced lift on the market today.

Please make sure to read through this manual before operating the lift.

Record the information on the nameplate label here:

Model No.:

Serial No.:

Manufacturer date:

WARRANTY

The warranty period for the steel structure part of new car lift is 5 years, hydraulic components, bronze bushings, sliders and plastic parts are under warranty for 3 years, and electrical components and sync cable, lock release cable warranty for 2 years.

Rubber pads are without warranty. During the warranty period, the manufacturer will repair or replace the defective parts free of charge including shipping costs.

This warranty does not cover damage caused by normal wear and tear, improper use, damage in transit, or damage caused by lack of maintenance.

This warranty is unique and supersedes what is expressed and implied in all other warranties. The manufacturer shall not be liable for any particular, indirect or accidental damage resulting in breach of or delay in the execution of the warranty. The manufacturer reserves the right to design and improve the product and has no obligation to make notice of the changes in advance.

The product warranty based on the above clause is based on the model number and serial number of the equipment. This information must be provided in conjunction with all warranty information at the time of service and warranty.

SAFETY WARNING LABEL



Fig.1


IMPORTANT SAFETY INSTRUCTIONS

In order to properly maintain your product and ensure operator safety, it is the responsibility of the product owner to read and follow these instructions!

1. Ensure product installation complies with all applicable local regulations and rules, such as Occupational Safety and Health Administration regulations and electrical codes.
2. Ensure that all operators are properly trained, know how to operate the unit safely, and are properly supervised.
3. Do not operate the lift until you are sure all parts are in place and operating correctly.
4. Keep your hands and feet away from the machine. Keep hands and feet away from any moving parts. Keep your feet away from the lift as it descends to avoid pressing on pointed objects.
5. Keep the work area clean. A cluttered workspace can lead to injuries.
6. The machine is only approved for indoor installation and use. Outdoor installation is prohibited.
7. Only trained operators are allowed to handle the lift machine. All untrained persons must stay away from the workplace. Never allow untrained persons to handle or operate the machine.
8. Use the lift properly. Use the lift in the correct way.
9. Warning! Keep persons and objects from the lift when lifting the a vehicle.
10. If the vehicle is at risk of falling, make sure no one is around the lift.
11. Before preparing to approach or service the vehicle, ensure that the safety device is in effect.
12. Dress appropriately when operating machines, and consider wearing non-slip steel-toe shoes for safety..
13. Beware of electric shock. In order to protect the operator from electric shock, the lift in use must be grounded. Do not connect the green wire to the terminal. This is the ground wire.
14. Danger! The power supply used in this type of lift has high voltage. Please disconnect the power supply before any circuit repair. Unplug in case the power supply is accidentally switched on during maintenance.
15. Warning! There is a risk of explosion. There are parts in the equipment that produce arc light and spark. Do not operate near flammable gas. This machine should not be placed in the lounge or basement.
16. Maintain with care. Keep the machine clean for better and safer operation. Perform

proper lubrication and maintenance procedures according to the manual. Keep handles or buttons clean, dry, and free of oil.

17. Stay alert. Use common sense to observe what you are doing and stay alert.
18. Check for damaged parts. Check for adjustments to moving parts, damage to parts, or anything that may affect their operation. Do not use the machine if the parts are damaged.
19. Do not remove relevant safety parts from the machine. Do not use a lift if it is damaged or missing.
20. Operate the lift only at temperature between 41°F to 104°F (5°C to 40°C).

 **DANGER** Be very careful when installing, operating, maintaining or repairing this equipment. Failure to comply may result in property damage, product damage, injury or (in very rare cases) death. Ensure that only authorized personnel operate the equipment. All repairs must be carried out by an authorized technician. Do not modify the machine, this voids the warranty and increases the probability of personal injury or property damage. Ensure to read and follow this instructions on the label.

I. PRODUCT FEATURES AND SPECIFICATIONS

FLOORPLATE CHAIN-DRIVE MODEL FEATURES

Model BP-12

- Lifting capacity:12,000lbs. The first heavy duty floorplate two post lift in China.
- Hydraulic cylinders: each cylinder is designed and made on high standards, utilizing imported oil seal in cylinder. Each cylinder has passed 25 Mpa test
- Available with 2 different width settings for installation. Distance between columns: 118 1/8" or 123 1/2" .
- Screw rubber pads with 3" and 6" extension adapters.
- Automatic arm restraints, with high-strength moon gear and arm lock.
- Self- lubricating UHMW Polyethylene sliders and bronze bush.
- Single-point safety release, and dual safety design.
- Areo cables used for synchronization.

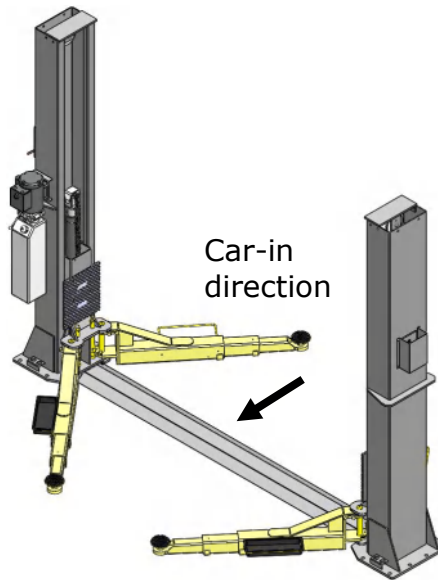


Fig.2

MODEL BP-12 SPECIFICATION

Model	Lifting Capacity	Lifting Time	With round rubber pad assy.				With saddle adapter assy.			
			Max Lifting Height		Max safety lock height		Max Lifting Height		Max safety lock height	
			Without extension adapter	Include extension adapter	Without extension adapter	Include extension adapter	Without extension adapter	Include extension adapter	Without extension adapter	Include extension adapter
BP-12	12,000lbs (5500KG)	65s	72 1/2" -73 7/8"	81 9/16" -82 7/8"	70 9/16" -71 7/8"	79 9/16" -80 15/16"	72 11/16" -74"	81 11/16" -83"	70 11/16" -72 1/16"	79 3/4" -81 1/16"

Overall Height	Overall Width	Minimum Pad Height		Motor
		With round rubber pad assy.	With saddle adapter assy.	
122 1/2"	145 3/8" / 150 3/4"	4 1/2"	4 11/16"	2.0HP

Arm Swings for Model BP-12

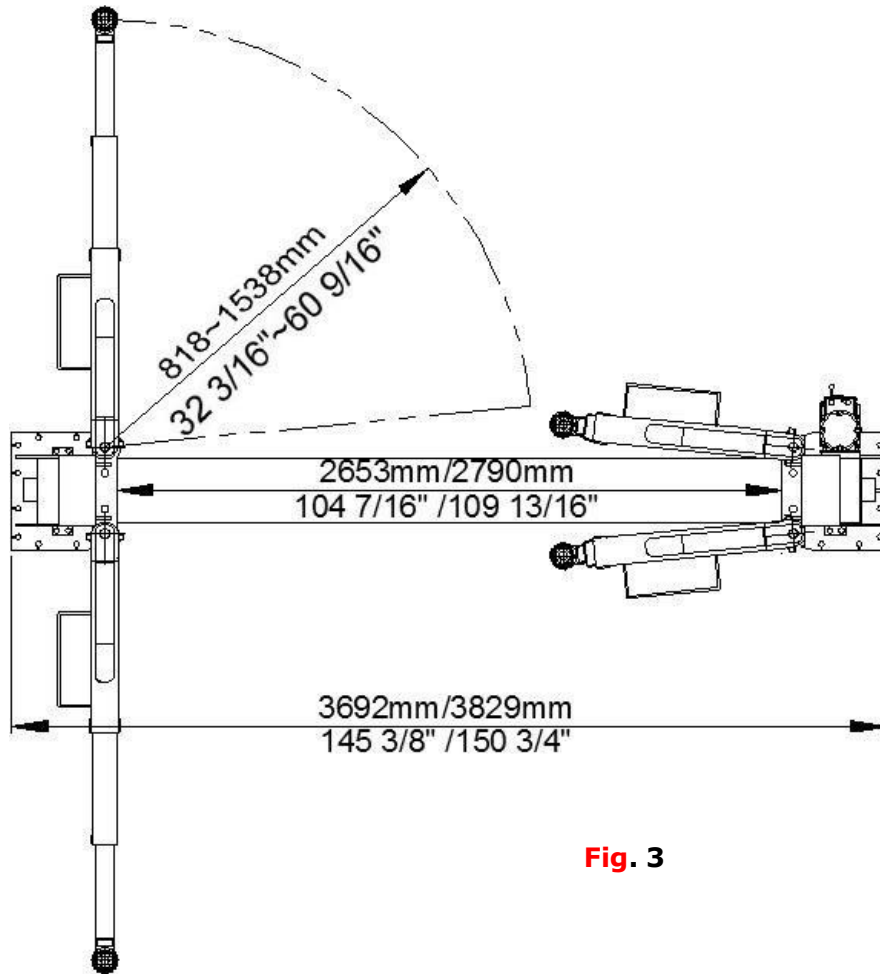


Fig. 3

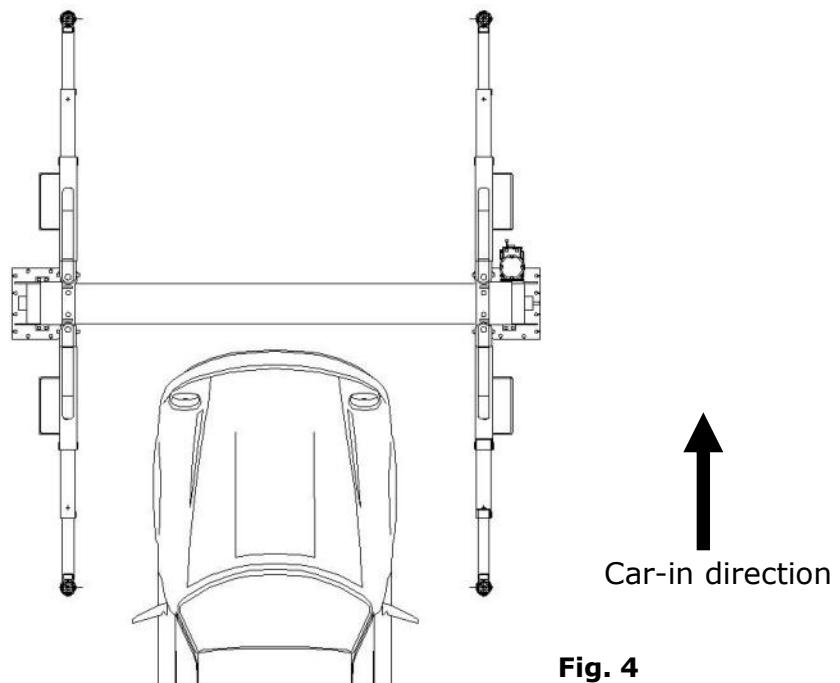


Fig. 4

⚠ CAUTION When driving the vehicle, stay in the middle between the columns. If you hit any part of the lift, you could damage the car or lift.

II. INSTALLATION REQUIREMENT

A. Tools Required

✓Rotary Hammer Drill ($\Phi 19$)



✓Hammer



✓Level Bar



✓English Spanner (12")



✓Ratchet Spanner with Socket (28#)



✓Wrench set

(8#, 10#, 13#, 14#, 17#, 19#, 24#)



✓Carpenter's ink marker



✓Screw Sets



✓Tape Measure (7.5m)



✓Pliers



✓Socket Head Wrench (3#, 5#, 8#)



✓Lock Wrench



Fig. 5

B. Equipment storage and installation requirements.

- 1 . Store the equipment in a dry, non-moldy, non-flammable environment.
- 2 . The lift is only approved for indoor installation and use, and outdoor installation is prohibited.
- 3 . When installing the device, take safety precautions according to the instructions to avoid device damage.
- 4 . Do not install the device outdoors if the installation area is not protected.
- 5 . During installation, all parts should be fastened to ensure the stability and smooth operation of the machine.
- 6 . After installation, the whole machine should be checked to make sure that every component is working properly.

C. The equipment should be unload and transferred by forklift.



Fig. 6

D. Specifications of concrete (See Fig. 7).

Specifications of concrete must be adhered to the specification as following.

Failure to do so may result in lift and/or vehicle falling.

1. Concrete must be thickness 5" minimum and without reinforcing steel bars, and must be dried completely before the installation.
2. Concrete must be in good condition and must be of test strength 3,500psi minimum. Solidify at least 15 days.
3. Floors must be level and no cracks.
4. Do not install the lift on asphalt or any surface other than concrete.

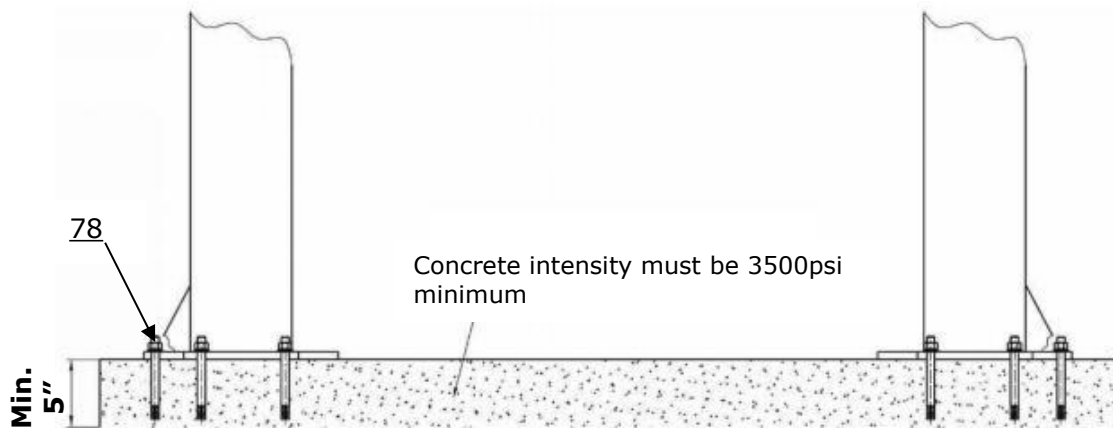


Fig.7

E. Power supply

1. You are required to use a licensed and qualified electrician for the installation process.
2. The power supply should be 3.0HP, with a minimum cord thickness of 12AWG , and must be properly grounded.

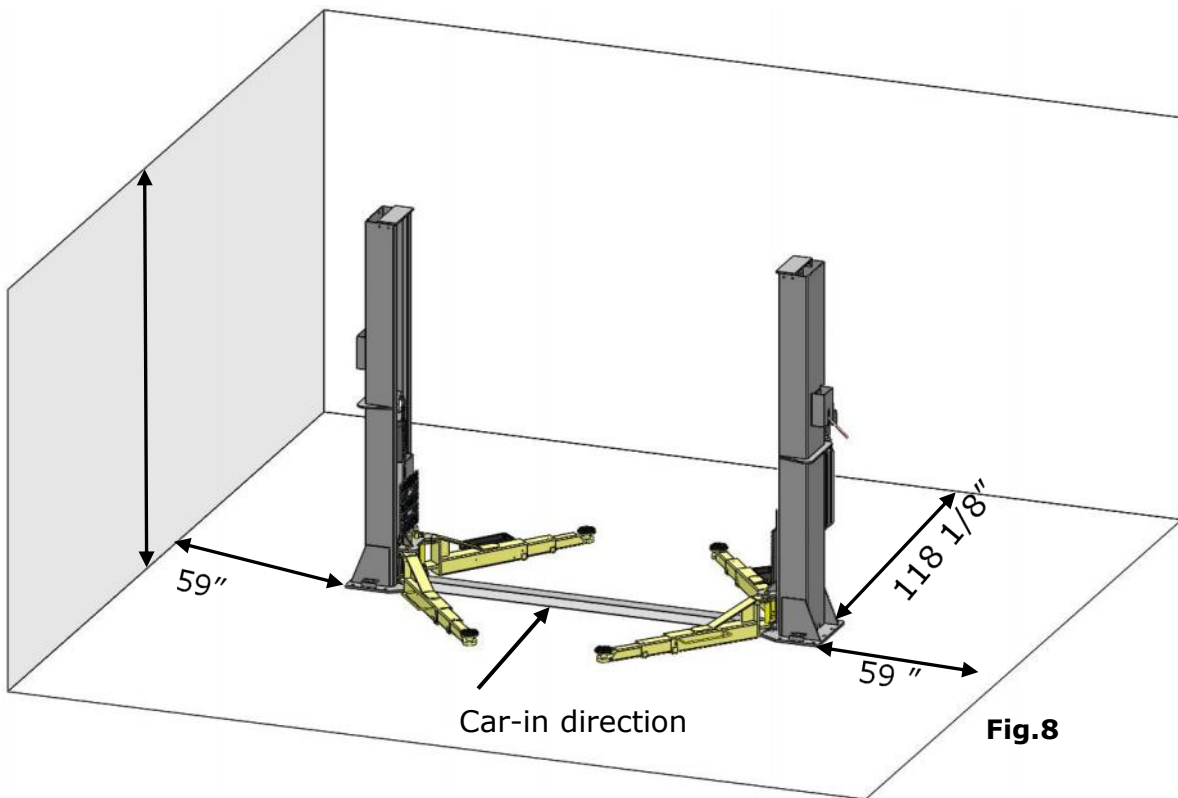
⚠ **DANGER** All electrical wiring must be performed by a licensed and certified electrician. Attempting to connect the circuit without proper certification may cause damage to the lift or electrocution, resulting in serious injury or death.

III. INSTALLATION STEPS

A. Location of Installation

1. Installation space: Ensure there is enough space for the lift. Accurately measure the front, back, side and top mounting dimensions and refer to the below figure data(See Fig. 8).
2. Overhead obstacle: Check for overhead obstacles, such as building supports, heaters, lights, wires, and low ceilings, etc..
3. Installation: The lift is only approved for indoor installation and use, and outdoor installation is prohibited.
4. Floor: Install lift only on flat concrete floor. Do not install on asphalt or any other surface. The surface must be flat.

Installation ceiling height requirement: > 10.2ft



CAUTION Installing the lift on a surface with slopes more than 3° could lead to injury or even death. AMGO lifts are designed for installation on a flat and level surface only. (Defined as no more than 3/8" difference over the installation area). If the floor cannot be leveled, consider changing installation locations.

ATTENTION: Lift installation and concrete construction must comply with the latest version of the national standard "Automotive Lifts - Safety Requirements for Construction, Testing and Verification"

B. Use a carpenter's chalk line to establish installation layout of base-plate (See Fig. 9).

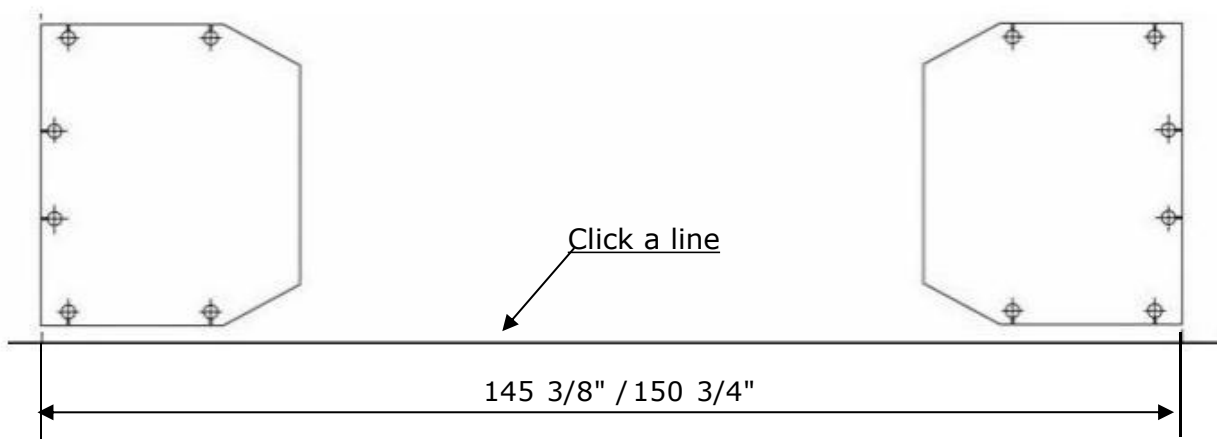


Fig.9

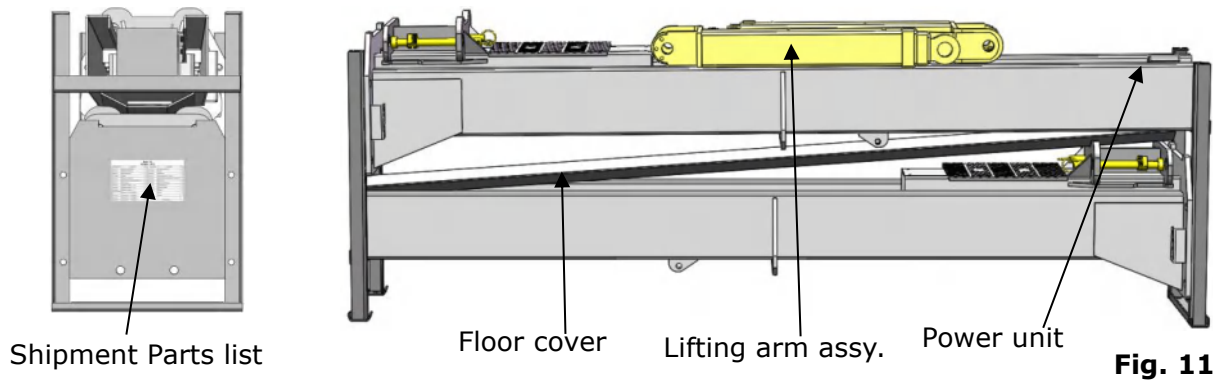
C. Check the parts before assembly.

1. Received lift and hydraulic power unit (See Fig.10).

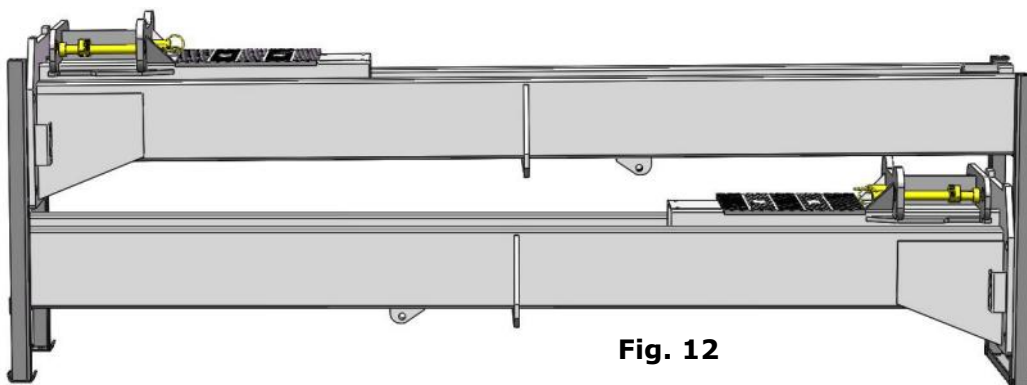


Fig. 10

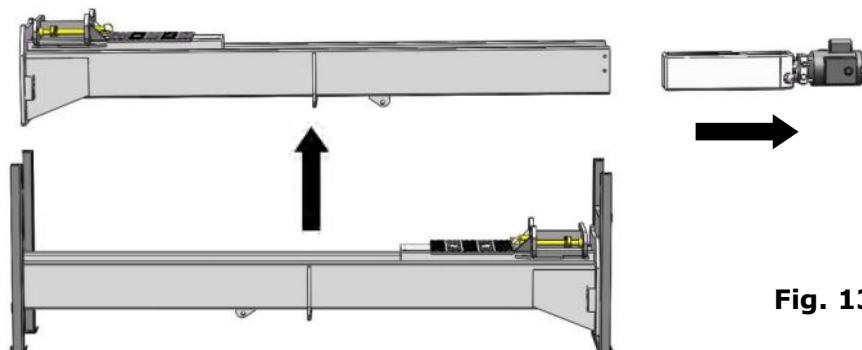
2. Move the lift aside with fork lift or hoist, and open the outer packing carefully, check all parts according to the shipment parts list. (See Fig. 11).



3. Take out the parts on and inside the column of top layer , then move aside to the installation site. (See Fig. 12).



4. Remove the bolts of the upper package, take out the column of top layer with forklift or manually, then remove the package stand.



5. Move aside all parts to installation site, and check according to the shipment parts list.

(See Fig. 13, 14).

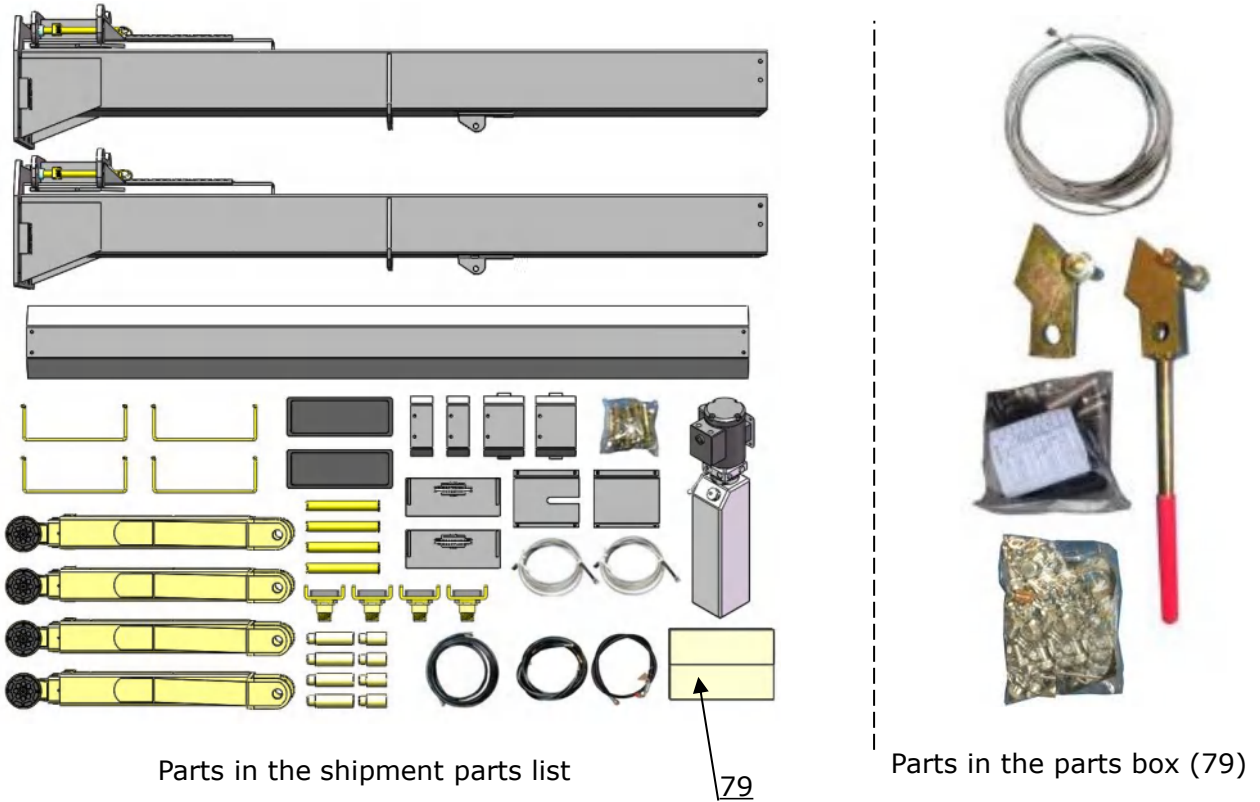


Fig. 14

6. Open the parts bag and check the parts according to parts bag list (See Fig. 15).

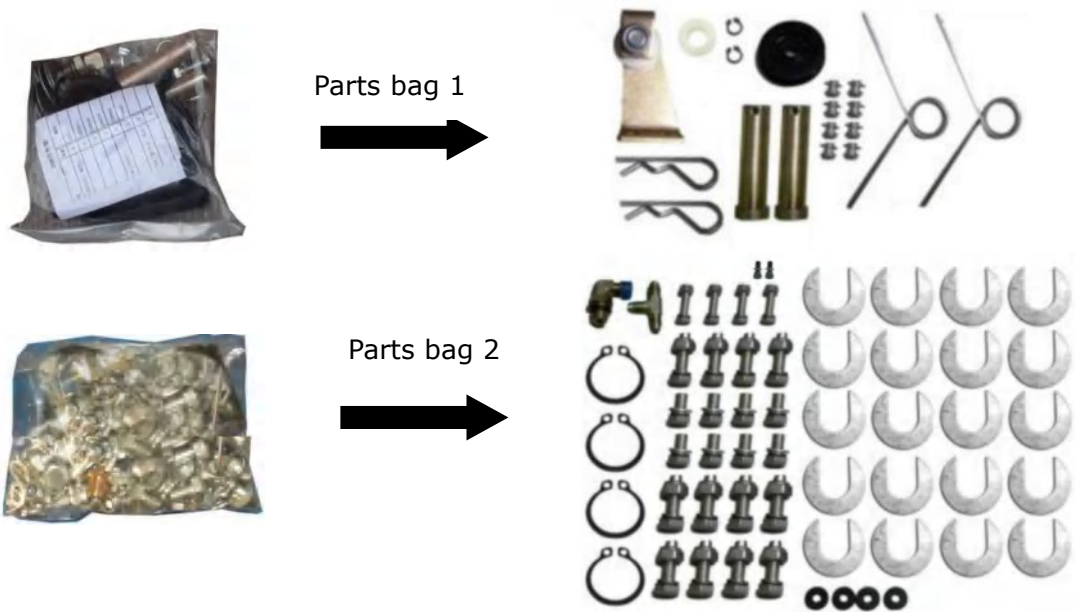


Fig. 15

D. Parallely lay down the two columns on the installation site, position the powerside column according to the actual installation site. Usually, it is suggested to install the powerside column on the front-right side from which vehicles are driven to the lift, then install the top plate (See Fig.16).

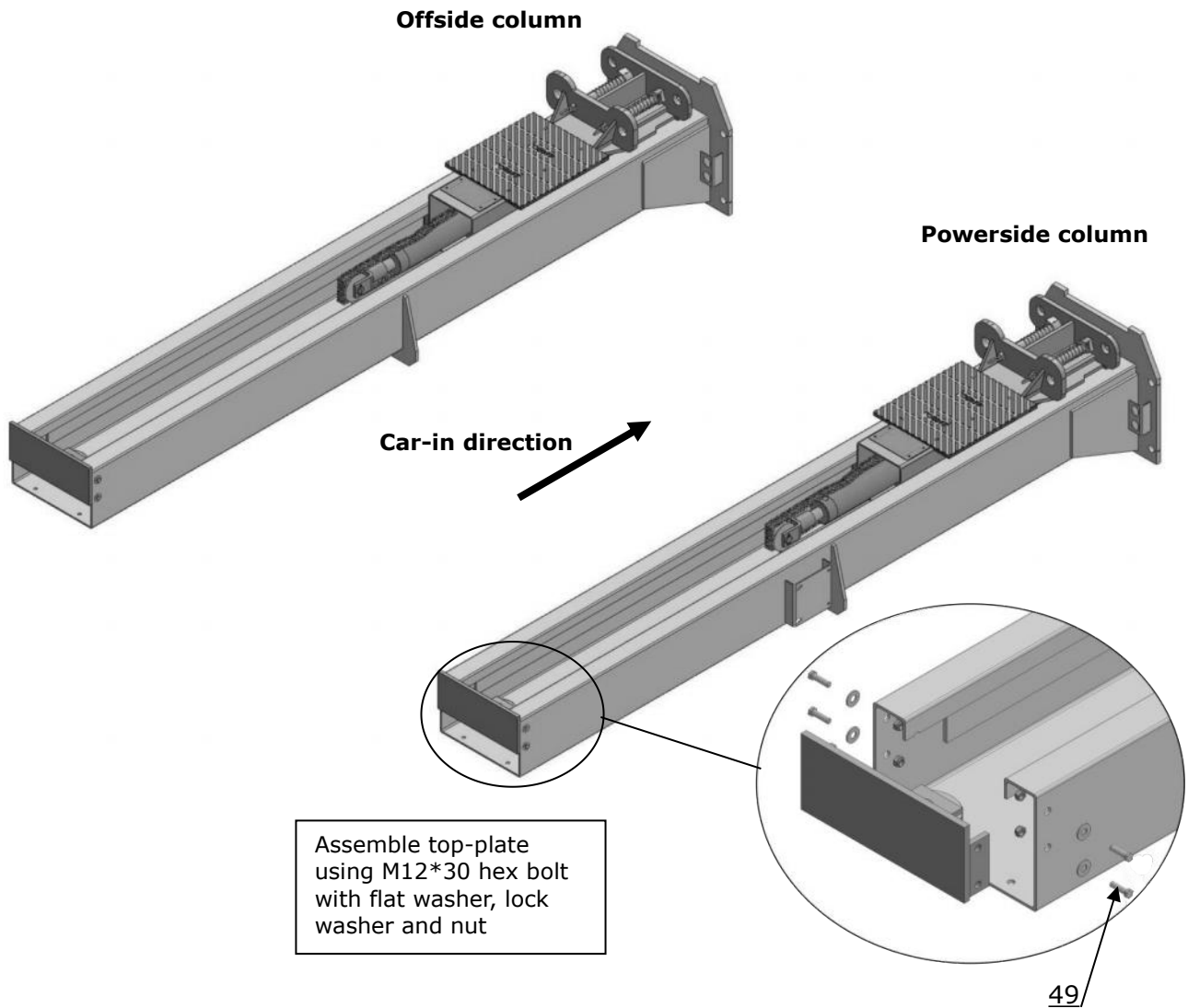
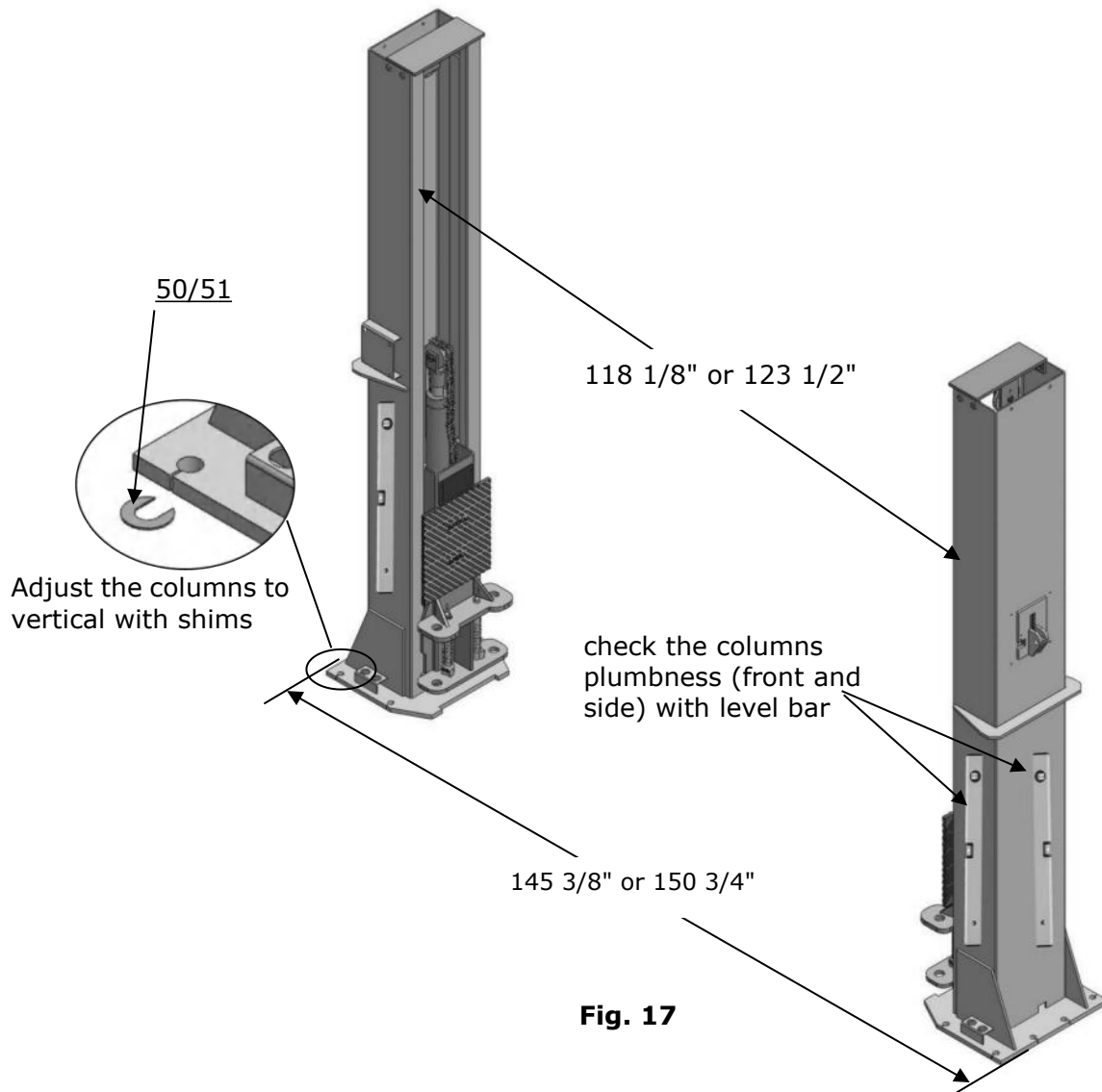


Fig. 16

E. Erect the columns , install anchor bolts, check the columns plumbness with level bar, and adjust with shims if the columns are not vertical, Don't tighten the anchor bolts at this time (See Fig. 17).

Note: There are 2 width settings for installation, please choose according to your need.



F. Fix anchor bolts

1. Prepare anchor bolts (See Fig. 18).

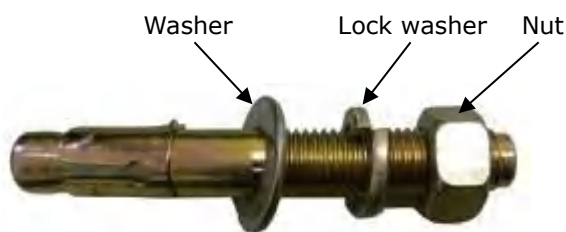


Fig. 18

2. Using the prescribed rotary hammer drill, and drill all the anchor holes and install the anchor bolts. Then tighten the anchor bolts (See Fig. 19).

Note: Torque of anchors is 150N.m. Minimum embedment of anchors is 110mm.

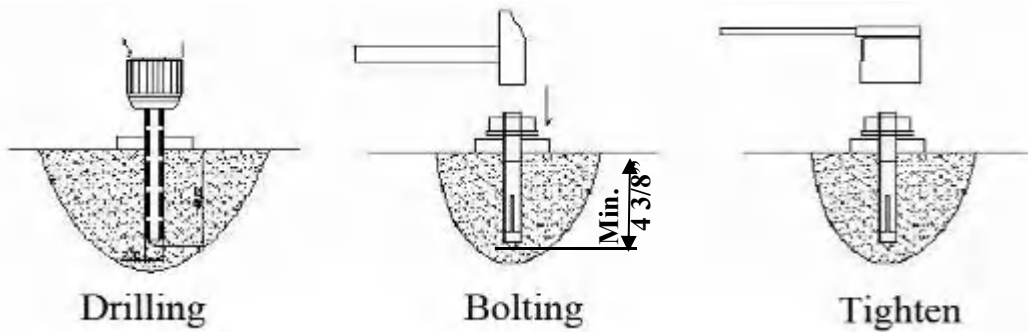
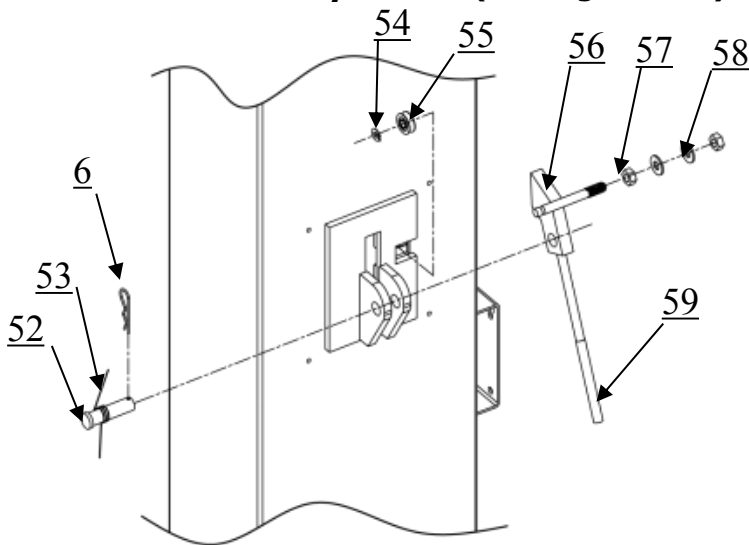


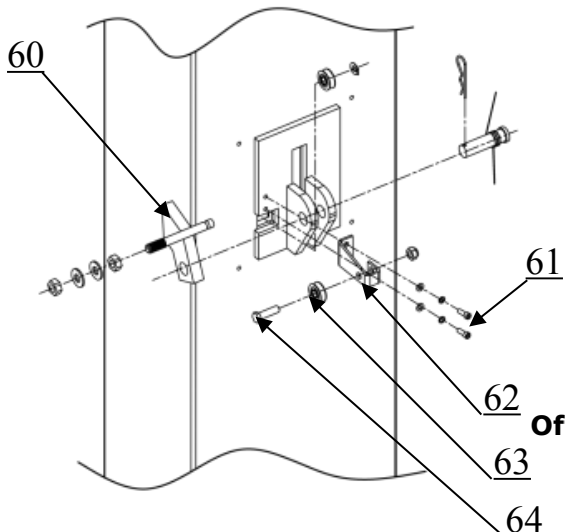
Fig. 19

⚠ **CAUTION** Concrete and anchor bolts must comply with above specifications. Install lifts only on concrete surfaces. If you are in asphalt or either any other surface on which the lift is mounted, or the concrete or anchor bolts do not meet these specifications, it may result in product damage, vehicle damage, personal injury, or even loss of life.

G. Install safety device (See Fig. 20&21).



**Power side safety device
Fig. 20**



**Offside safety device
Fig. 21**

H. Install sync cables

Raise both sides of carriages and lock them to the same level.

1. For narrow installation (distance between 2 columns: 118 1/8")

1.1 Pass the cable from the bottom to the top of carriage, pull it out from the hole of carriage and then tighten the two cable nuts. See fig 22.

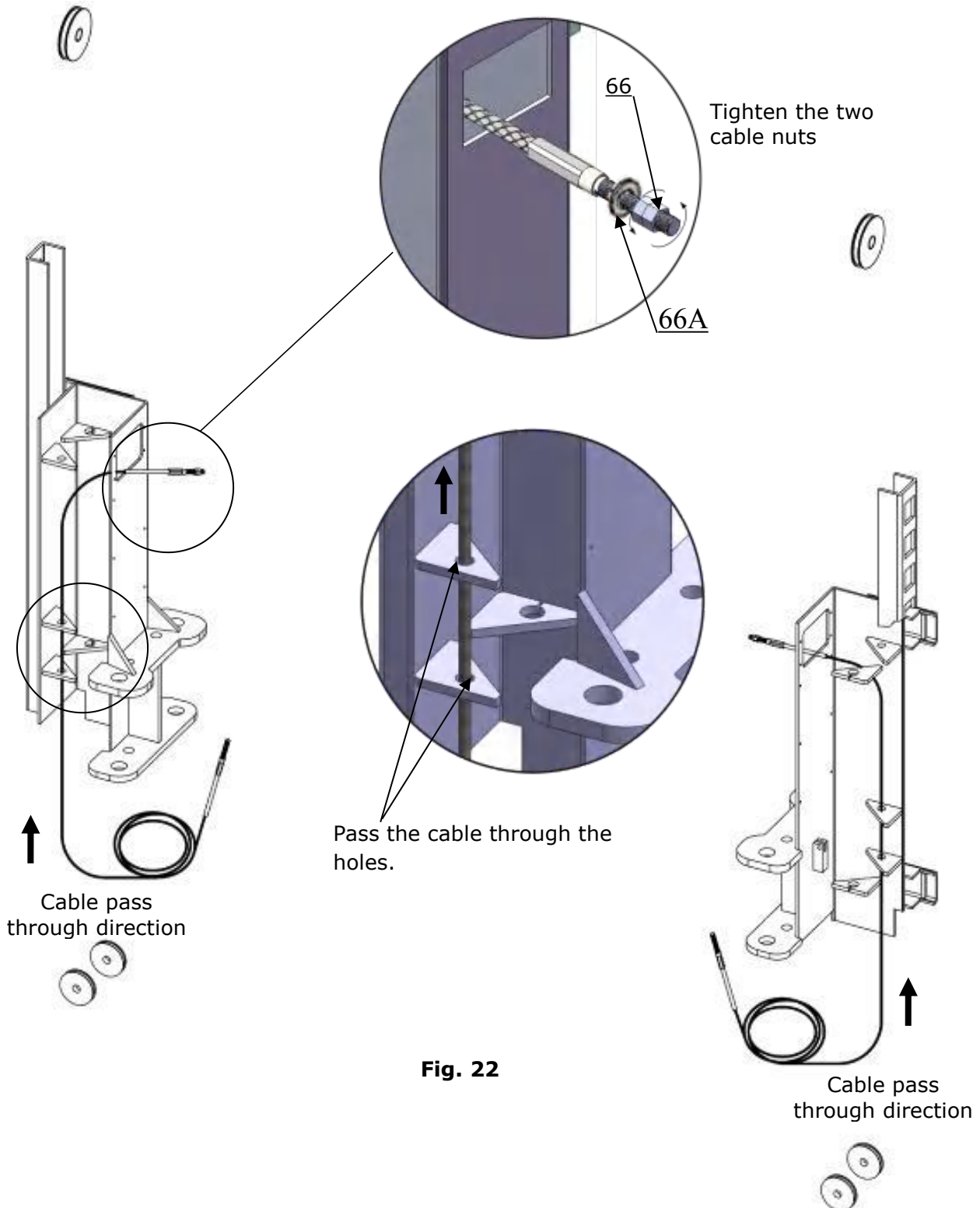


Fig. 22

1.2 Illustration of sync cable connection.

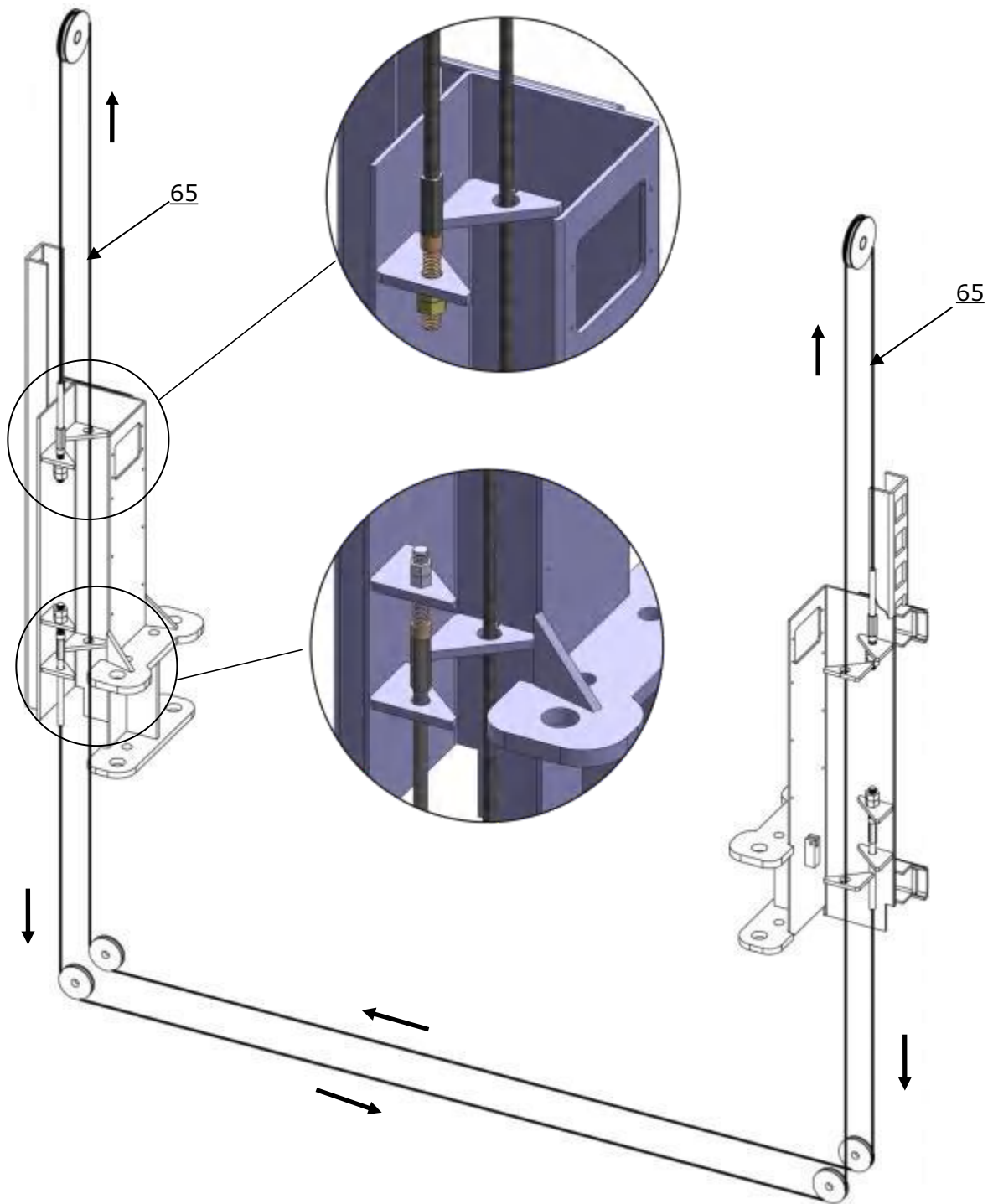


Fig. 23

2. For wide installation (distance between 2 columns: 123 1/2")

2.1 Pass the cable from the bottom to the top of carriage, pull it out from the hole of carriage and then tighten the two cable nuts.

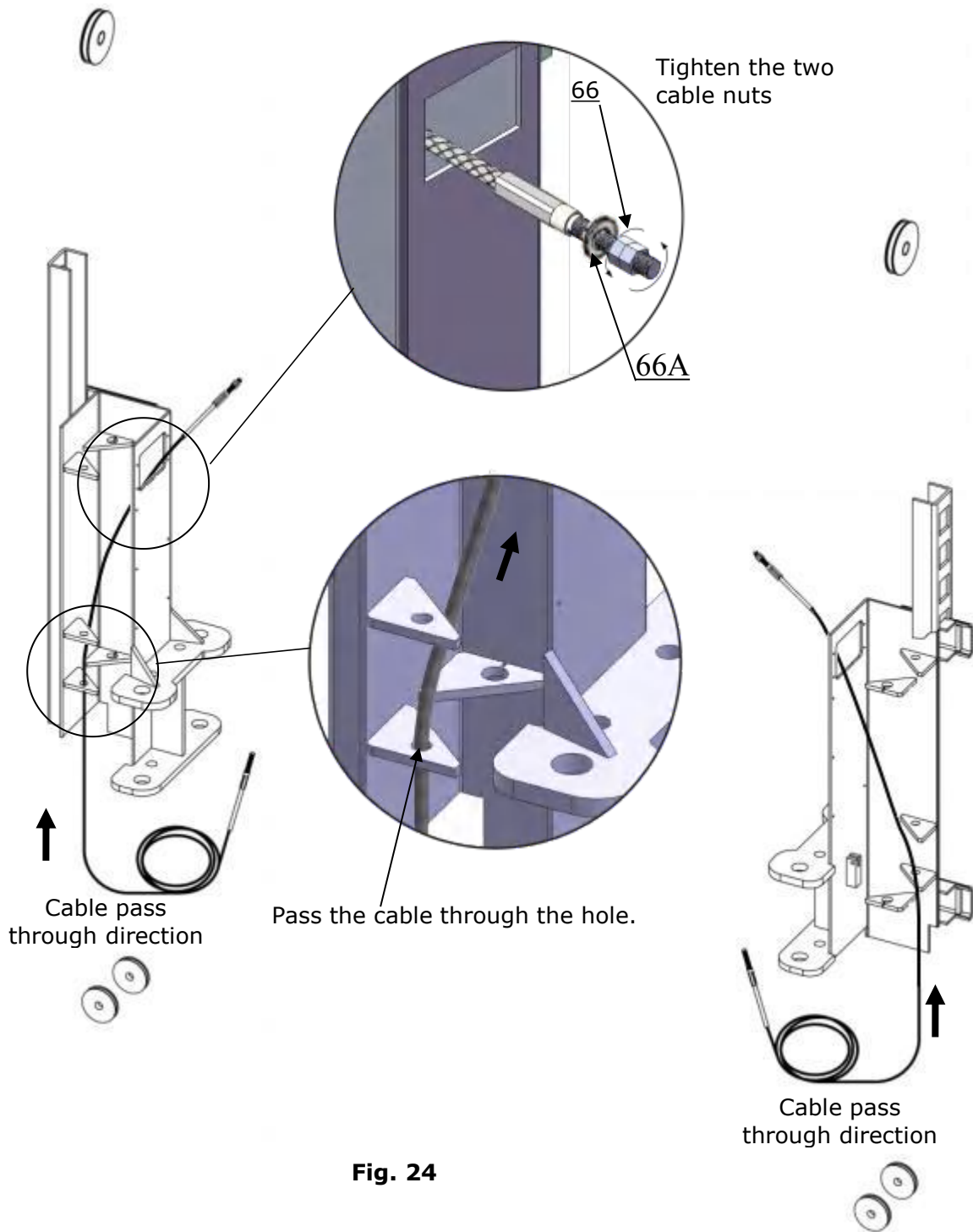


Fig. 24

2.2 Illustration of sync cable connection.

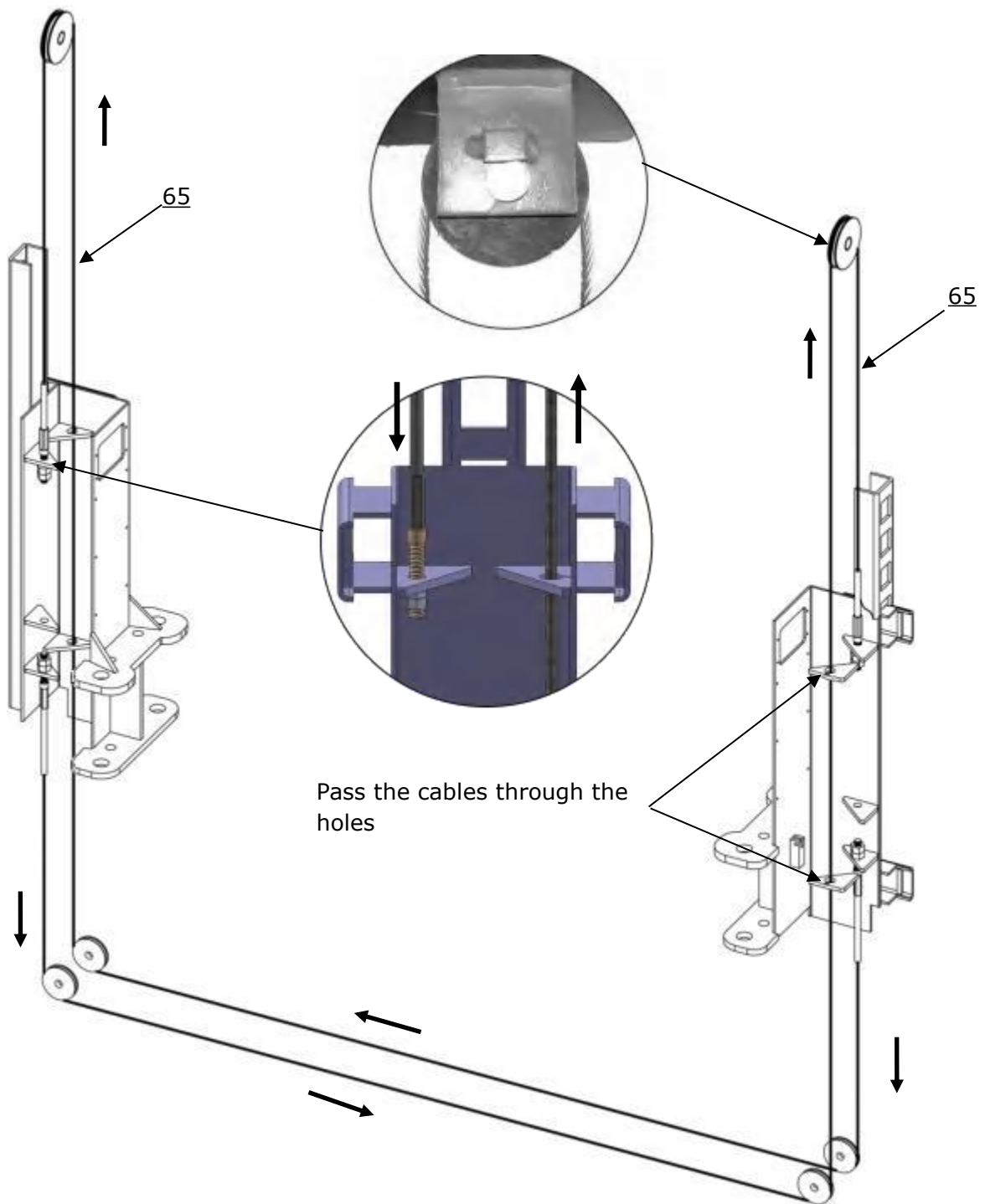


Fig. 25

I. Install safety cable (See Fig. 26).

Note: Install the safety cable from the offside safety device, pay attention to the pass through direction.

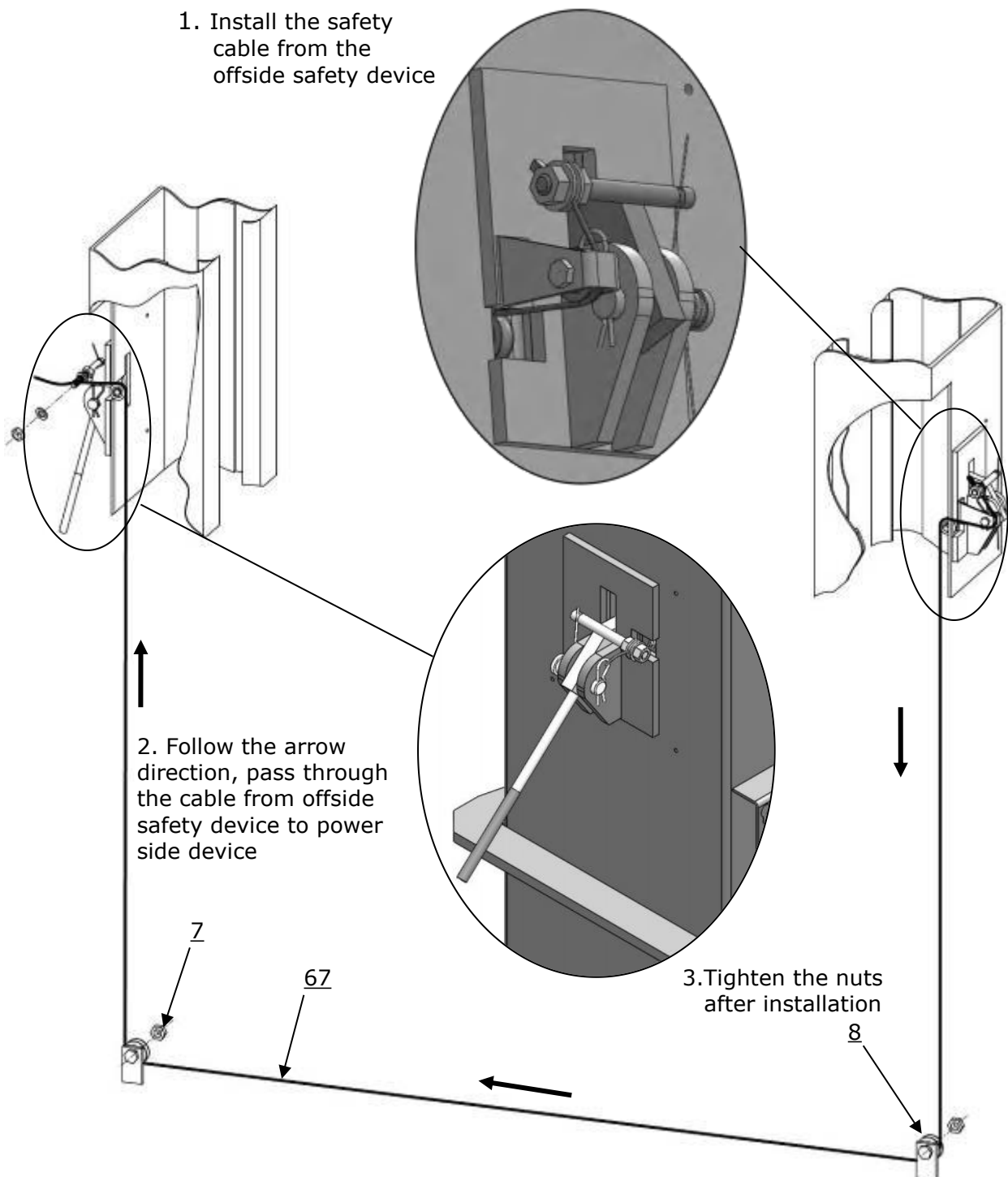
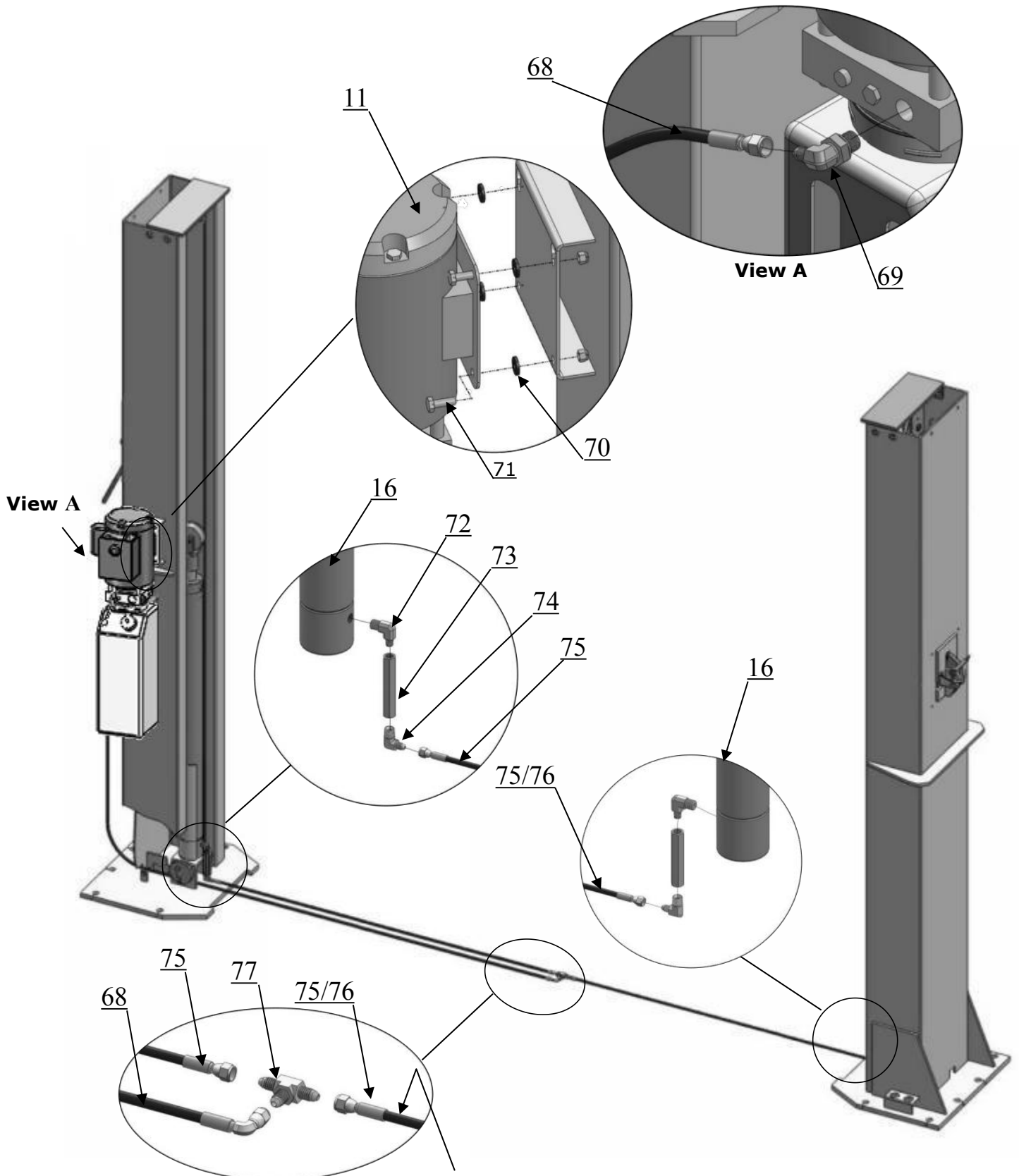


Fig. 26

⚠ DANGER Make sure the safety devices are properly installed before using the lift.

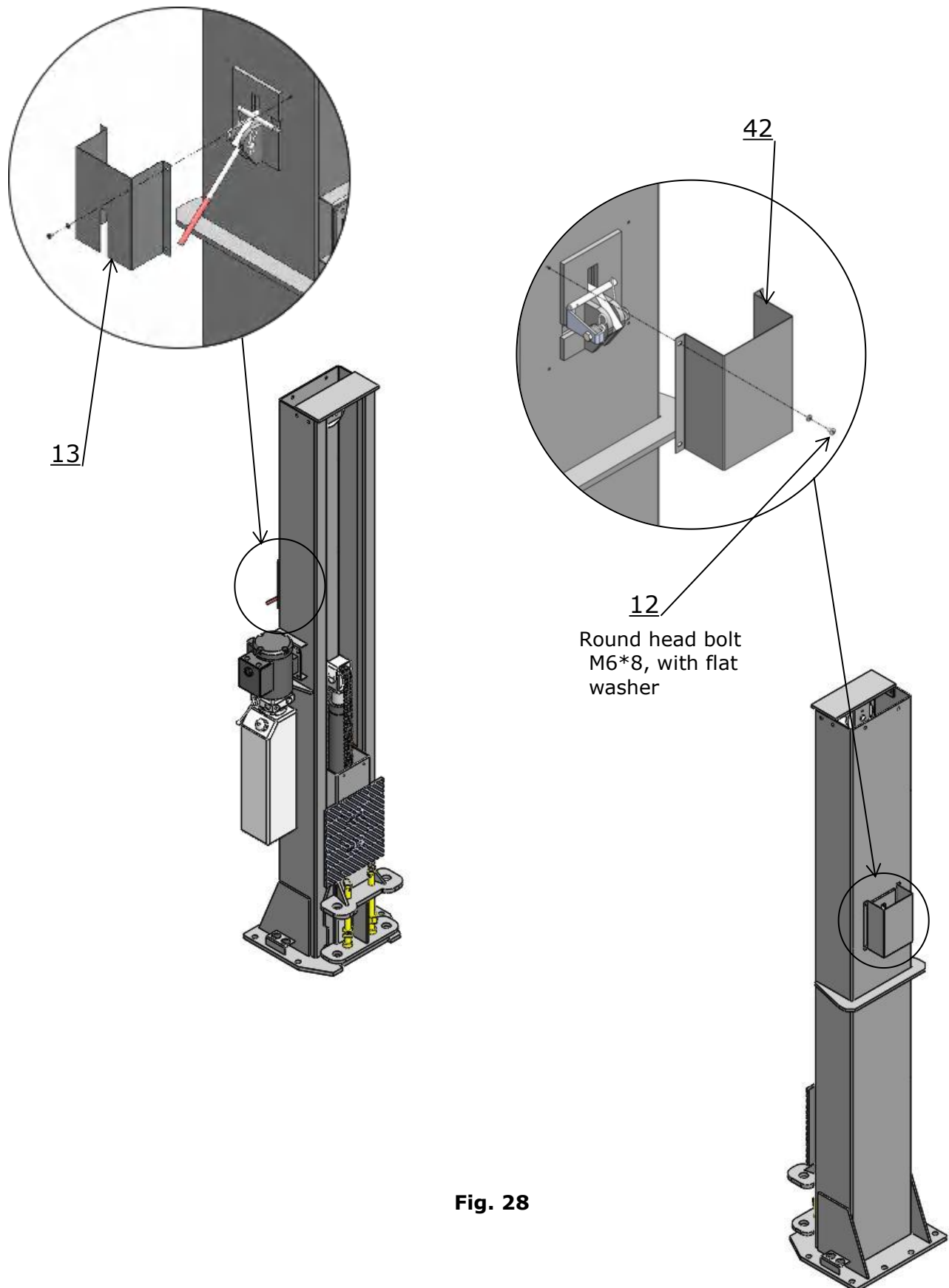
J. Install hydraulic power unit and oil hose assy. Tighten all hydraulic fittings after installation. (See Fig. 27).



For narrow installation (distance between columns :118 1/8"), use oil hose # **76**(L= 54 23/32").
 For wide installation (distance between columns:123 1/2"), use oil hose # **75**((L= 59 27/32").

Fig. 27

K. Install safety device protect cover. Fig 28



L. Install floor cover (See Fig. 29).

NOTE: Choose different extension cover according to installation width in Step E. .

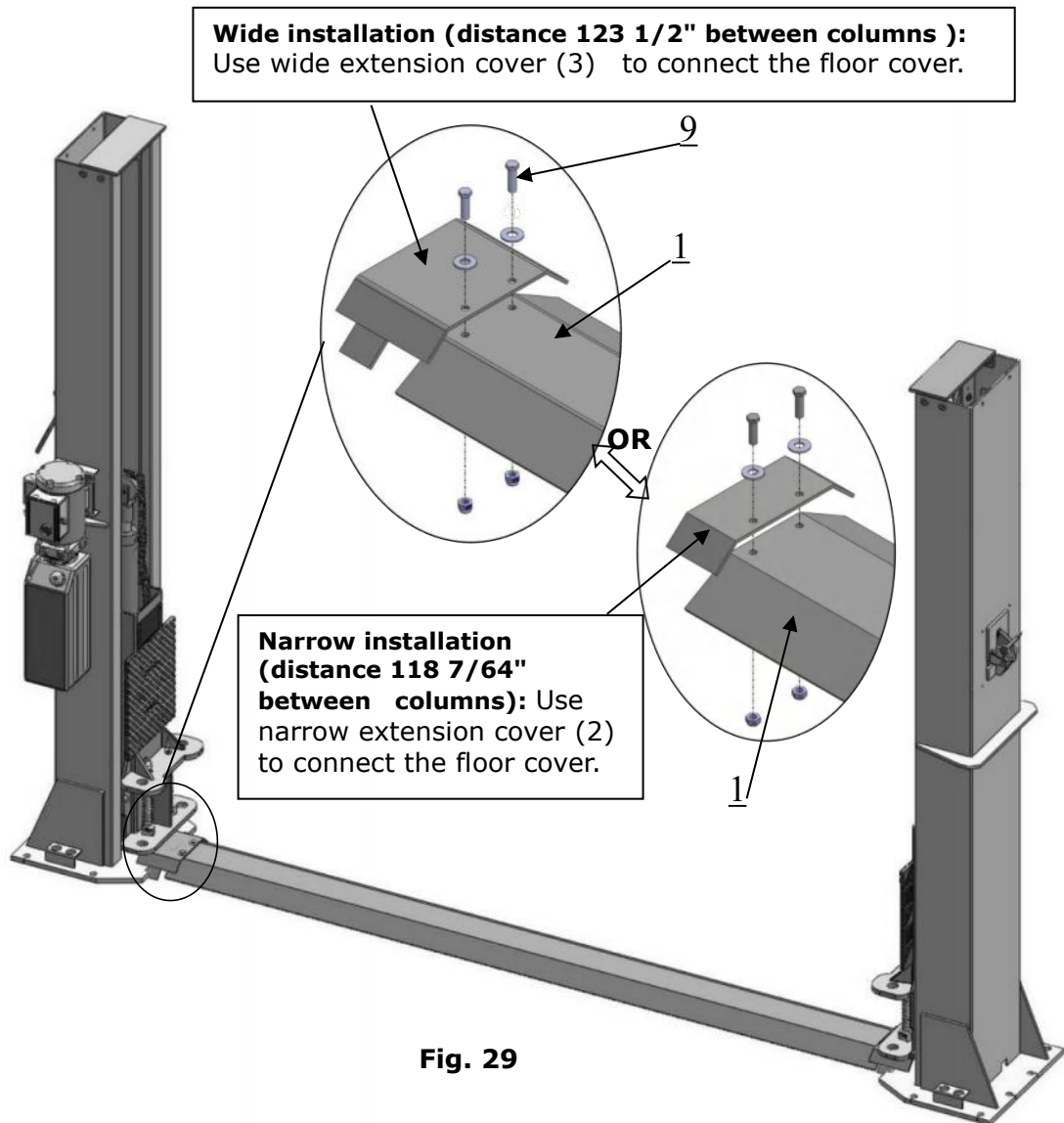


Fig. 29

M. Install lifting arms.

1. Install lifting arms according to the figure, then install spring on the arm pin and install toe guard.

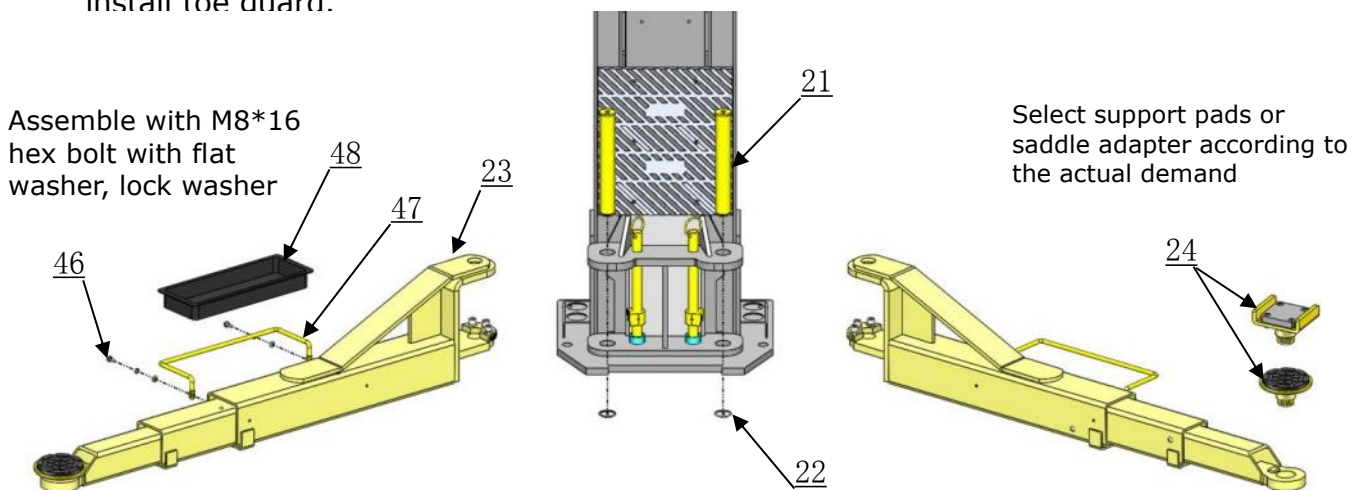
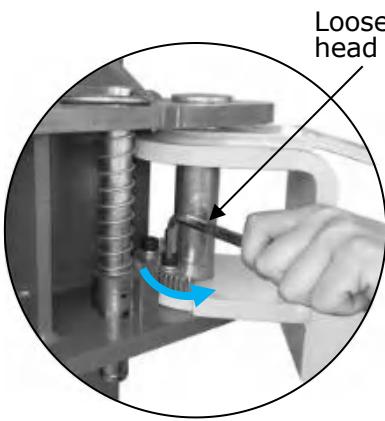


Fig. 30

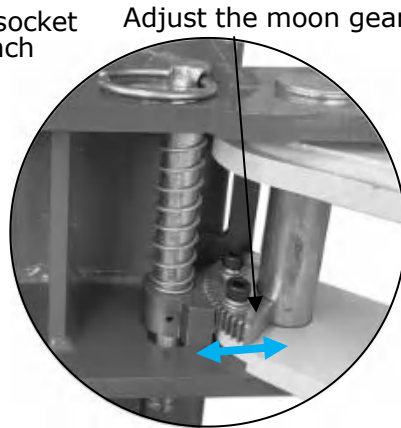
2. Lowering the carriages down to the lowest position, then use the 10# socket head wrench to loosen the socket bolt (See Fig. 31); follow the arrow direction to adjust the moon gear(See Fig. 32); lock the bolts after the moon gear and arm lock are engaged well(See Fig. 33).

The process of engaging arm lock and moon gear



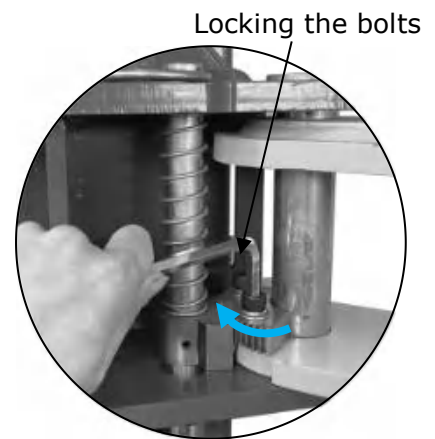
1. Use the 10# socket head wrench to loose the socket bolt

Fig.31



2. Follow the arrow direction to adjust the moon gear

Fig.32



3. Lock the bolts after the moon gear and arm lock are engaged well

Fig.33

⚠ DANGER Moon gear must be positioned and adjusted correctly. The lift should not be operated until the gears are fully engaged, and it is important to regularly check and adjust the arm restraint gears on all four arms. Failure to do so may result in vehicle damage, injury, or even death.

⚠ WARNING Each arm restraint assembly must be inspected and adjusted before you use the Lift each and every time. Do not operate the Lift if any of the four arm restraint systems are not functioning properly. Replace any broken components or components with broken teeth with authorized replacement parts only.

N. Fill the reservoir with hydraulic oil.

Note: In consideration of power unit’s durability and keep the equipment running in the perfect condition, please use hydraulic oil 46#

P. Refer to the circuit schematic diagram and connect the power supply according to the motor nameplate.

Note: To ensure the safety of the operator, the lift must be well grounded. When using a three-phase motor, pay attention to the forward and reverse rotation of the motor.

Single phase motor Circuit diagram (See Fig.34)

Connecting the two hot wires of power supply to terminals of AC contactor marked L1, L3 respectively. Earth wire is connected with the earth wire terminal of the motor.

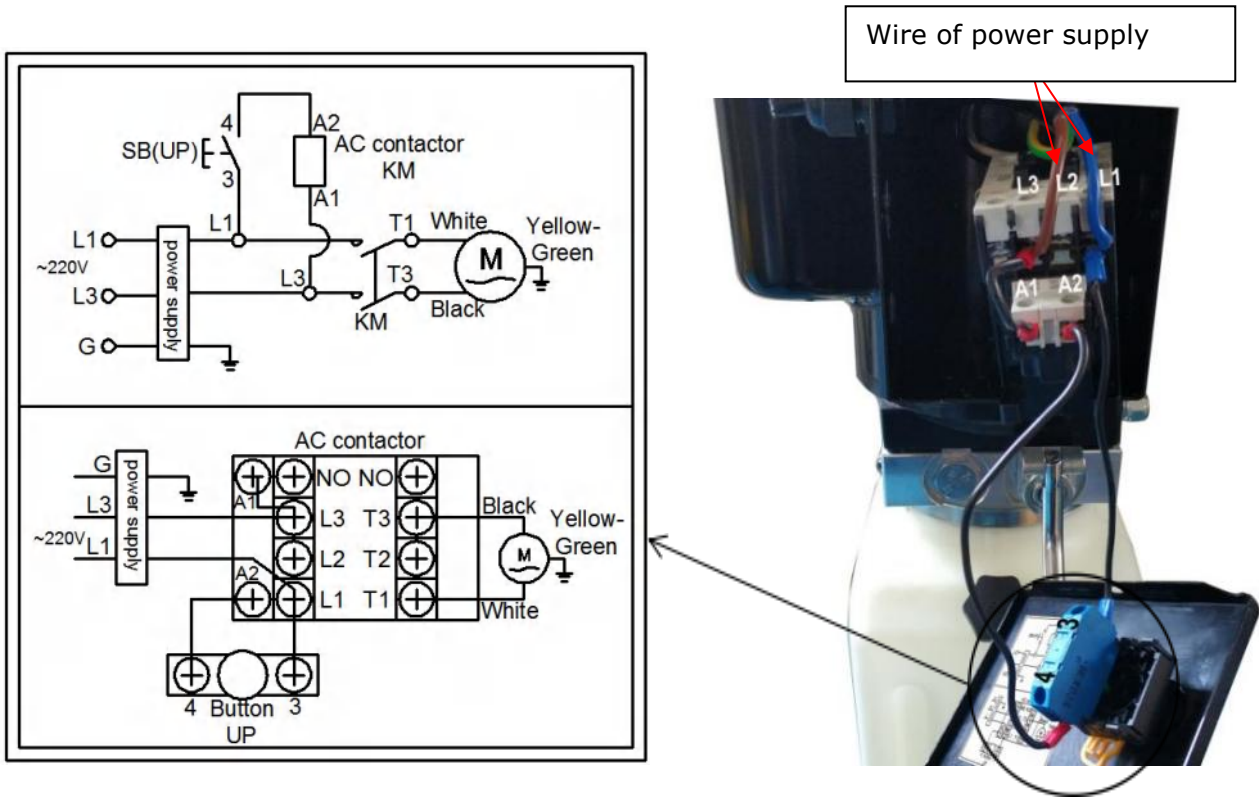


Fig. 34

⚠ DANGER All electrical wiring must be performed by a licensed and certified electrician. Before ensuring the main power has disconnected from the lift and cannot be re-applied until all procedures have been completed, don not perform any maintenance or installation to the lift.

⚠ DANGER Do not use the lift if the wires are damaged or severely worn. If the vehicle rises without noticing damage or extreme wear, carefully lower the vehicle to the ground. Once the lift is on the ground, remove it, disconnect the power, and arrange for protection.

IV. EXPLODED VIEW

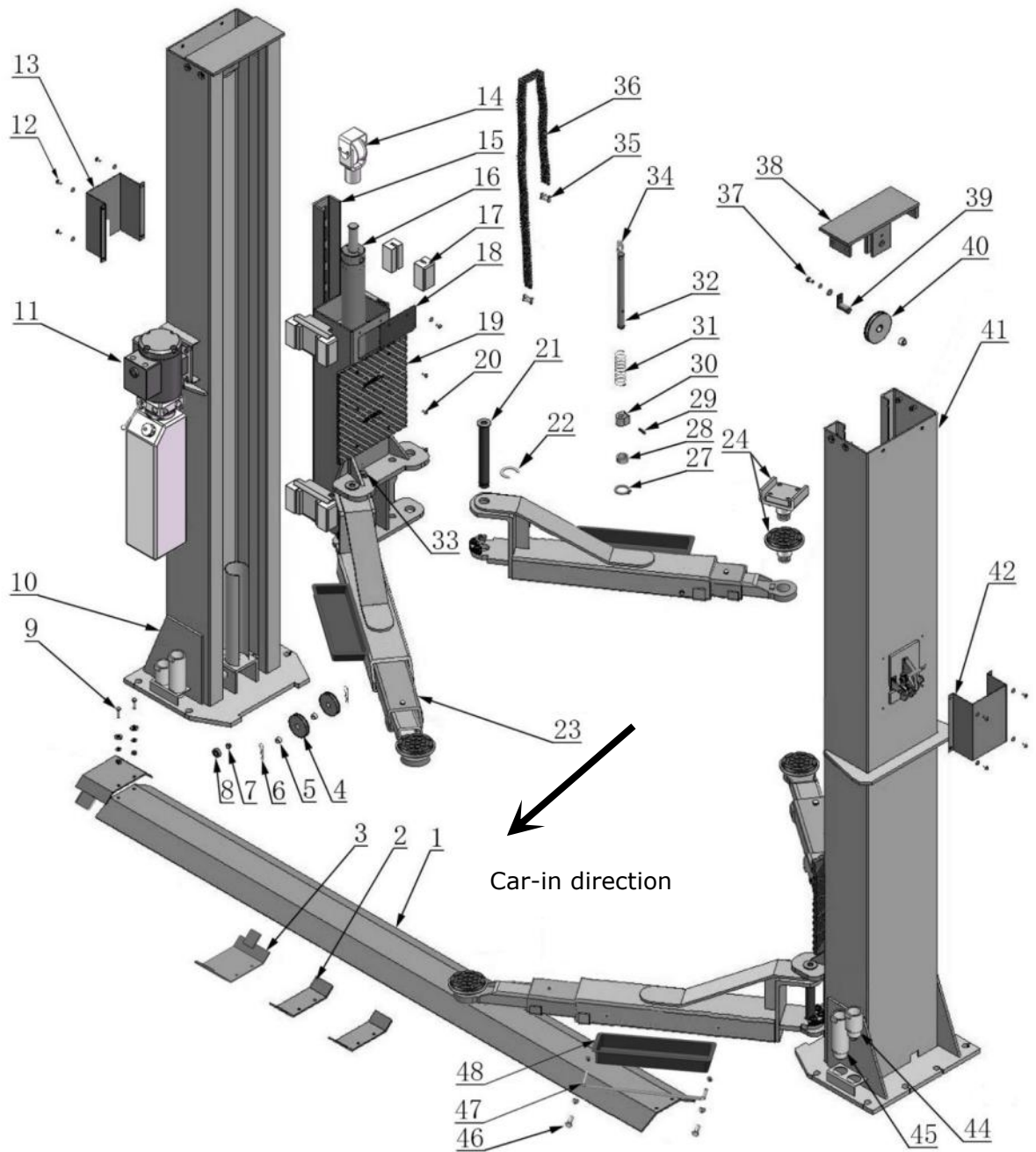


Fig. 35

PARTS LIST

Item	Part No.	Description	Qty.
1	11207001	Floor cover	1
2	11207002	Narrow extension cover	2
3	11207003	Wide extension cover	2
4	11217019-02	Top pulley	4
5	10217020	Bronze bush for pulley	6
6	10209012	Snap pin	6
7	10209056	Nylok nut M10	2
8	10209049	Plastic pulley (black)	2
9	1004574011	Hex bolt M8*20 (w/ flat washer, lock washer, hex nut)	4
10	11207053-01	Power side column	1
11		Manual Power Unit (Single phase)	1
12	1002735004	M6*8 round head bolt (w/ flat washer)	12
13	11207005	Power side safety device cover	1
14	11207681	Chain pulley seat assy.	2
15	11207009A-02	Carriage	2
16	C804207	Cylinder	2
17	1002755015	Slider block	16
18	11207047	Carriage plastic cover	2
19	10217053	Protective Rubber	2
20	10209019	Screw M6*16	12
21	11217047B	Arm pin	4
22	10520023	Clip ring	4
23	10212003001C	Lifting arm assy.	4
24	1102214015C	Single screw rubber pad assy.	4
	1102185006C	Single screw saddle adapter assy.	4
27	10610008	Clip ring	4
28	1102163002	Cushion cover of Spline	4
29	10206036-01	Cotter Pin	4
30	1002163001	Arm lock	4
31	10217045A-01	Spring	4
32	11217046B	Left arm lock bar	2
33	11217046C	Right arm lock bar	2
34	10209153	Arm lock bar ring	4
35	10201010A	Chain connector	4
36	10207015	Chain	2
37	1002205001	Hex bolt M10*15 (w/ flat washer, lock washer)	2
38	11207016	Top plate assy.	2
39	11217037	Pin for bottom pulley	2

Item	Part No.	Description	Qty.
40	11217036-02	Big Pulley	2
41	11207054-01	Off-side column	1
42	11207018	Off-side safety cover	1
44	1102214016A-01	Extension 3"	4
45	1102504001-01	Extension 6"	4
46	1002735012	M8*16 hex bolt (w/ flat washer, lock washer)	8
47	11206191	Toe guard(Short)	4
48	10206190	Tool tray(Short)	2
49	1002205002	M12*30 hex bolt (w/ flat washer, lock washer, hex nut)	8
50	10620065	Shim 3/32"	10
51	10201090	Shim 1/32"	10
52	1102011004A	Pin for safety lock	2
53	10209007A	Spring	2
54	10209010	Clip ring	2
55	10209011	Plastic small pulley (P005A-1)	2
56	11207019	Power side safety device	1
57	10206023A	Hex nut M12	4
58	10206006	Φ12 flat washer	4
59	10206003A	Rubber sleeve for release handle	2
60	11207020	Off-side safety lock	1
61	1002205003	M6*15 hex bolt (w/ flat washer, lock washer)	2
62	11217029-01	Pulley bracket	1
63	10206009	Plastic small pulley	1
64	1002735010	M10*35 hex bolt (w/ flat washer, lock washer)	1
65	10207022-01	Sync cable assy. L=331 1/2"	2
66	10610096	Cable nut M18	8
66A	1004334003	Flat washer φ18	4
67	10206149	Safety cable L=293 5/16"	1
68	10207023-01	Oil hose L=126 3/8"	1
69	10209060	90° Fitting for power unit	1
70	10209004	Rubber ring	4
71	1004574014	M8*25 hex bolt (w/ flat washer, nylok nut)	4
72	10207024	90° Fitting 3/8NPT(M)*1/4NPT(M)	2
73	11207035	Extended fitting	2
74	10420097	90° Fitting 1/4NPT(M)*1/4JIC(M)	2
75	10207026	Oil hose L=59 27/32"	2
76	10207034	Oil hose L=54 23/32"	1
77	10211016	T fitting	1
78	10201140	Anchor bolt	12
79	10207500A	Parts box	1

1. Exploded view of lifting arm assembly (10212003001C)

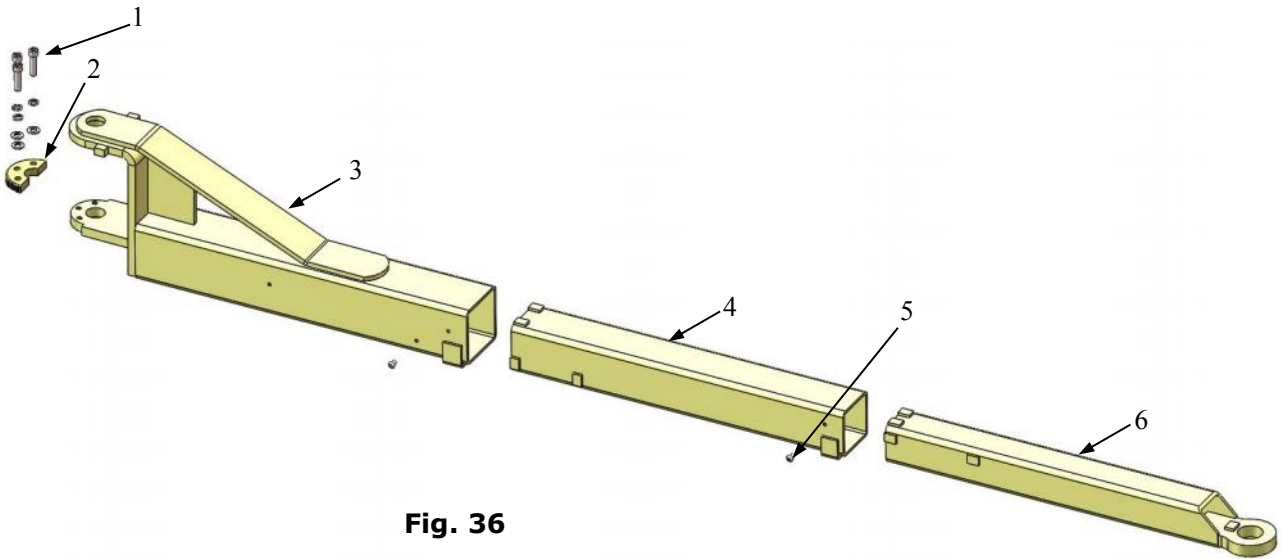


Fig. 36

Item	Part No.	Description	Qty.
1	1002205004	Socket bolt M12*48 (w/ flat washer, lock washer)	3
2	1102163001	Moon gear	1
3	10212003001A	Outer arm	1
4	10212003003A	Middle arm	1
5	10201149	Round head bolt M8*12	2
6	10212003004A	Inner arm	1

2. Exploded view of Chain pulley seat assy. (11207681):

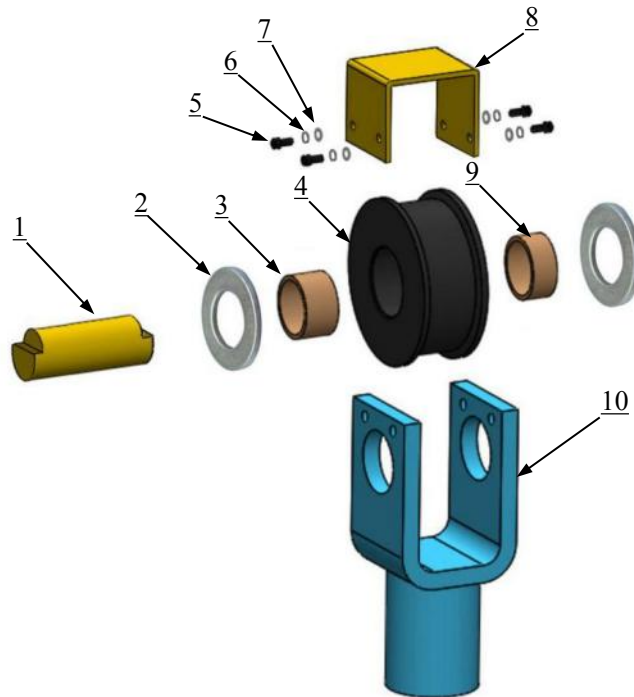
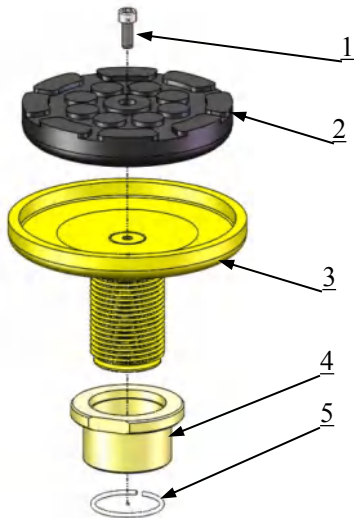


Fig. 37

Item	Part No.	Description	Qty.
1	11207006-01	Pin for Chain Pulley	1
2	11530023	Flat washer $\Phi 44*\Phi 35.5*2$	2
3	10420132A	Bronze Bush	1
4	11207007	Chain Pulley	1
5	1001012002	Hex Bolt M6*15	4
6	10209149	Lock washer $\Phi 6$	4
7	10420045	Flat washer $\Phi 6$	4
8	11207693-01	Chain limit block	1
9	10530042	Bronze Bush	1
10	11207008-01	Chain Pulley Seat	1

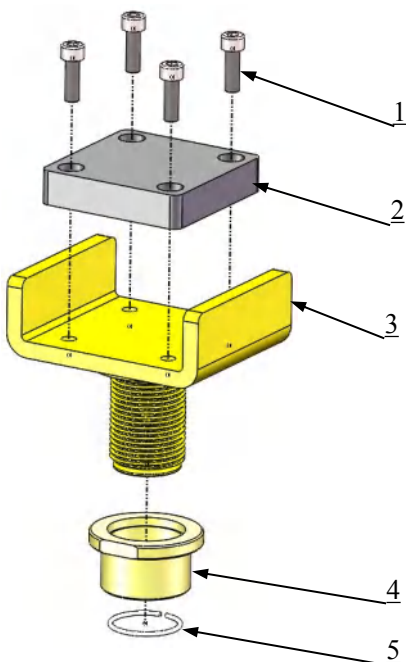
3. Single Screw Rubber Pad Assy. Exploded View (1102214015C) :



Item	Part No.	Description	Qty.
1	10420138	Socket Bolt M6*16	4
2	10209134	Rubber Pad	4
3	1102214015	Support frame	4
4	1101043004	Adjusting sleeve	4
5	10203042	Snap ring	4

Fig. 38

4. Single Screw Rubber Pad Assy. Exploded View (1102185006C) :



Item	Part No.	Description	Qty.
1	10720061	Socket Bolt M8*15	16
2	1102194001	Rubber Pad	4
3	1102185006A	Saddle support frame	4
4	1101043004	Adjusting sleeve	4
5	10203042	Snap ring	4

Fig. 39

5.Exploded view of the oil Cylinder C804207 (Old code 10207010)

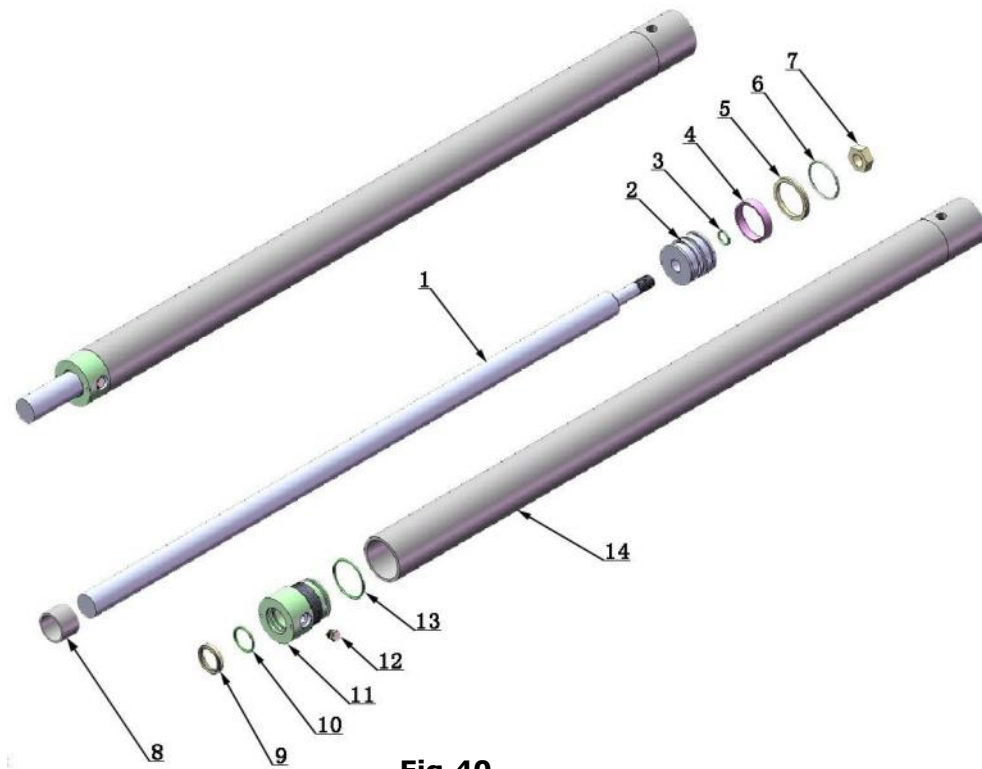


Fig.40

Item	Part No.	Description	Qty.
1	11207027	Piston Rod	1
2	11207028	Piston	1
3	10206069	O-Ring	1
4	10620053	Support Ring	1
5	10620054-01	Y-Ring	1
6	10630027	O-ring	1
7	10206071	Hex Nut	1
8	10207029	Adjustment Tube Cylinder Adjustment Tube	1
9	10217078	Dust Ring	1
10	10520058	O-Ring	1
11	11207030	Head Cap	1
12	10201034	Bleeding Plug	1
13	10207031	O-Ring	1
14	11207032	Cylinder Tube	1

6. Illustration of hydraulic valve for power unit

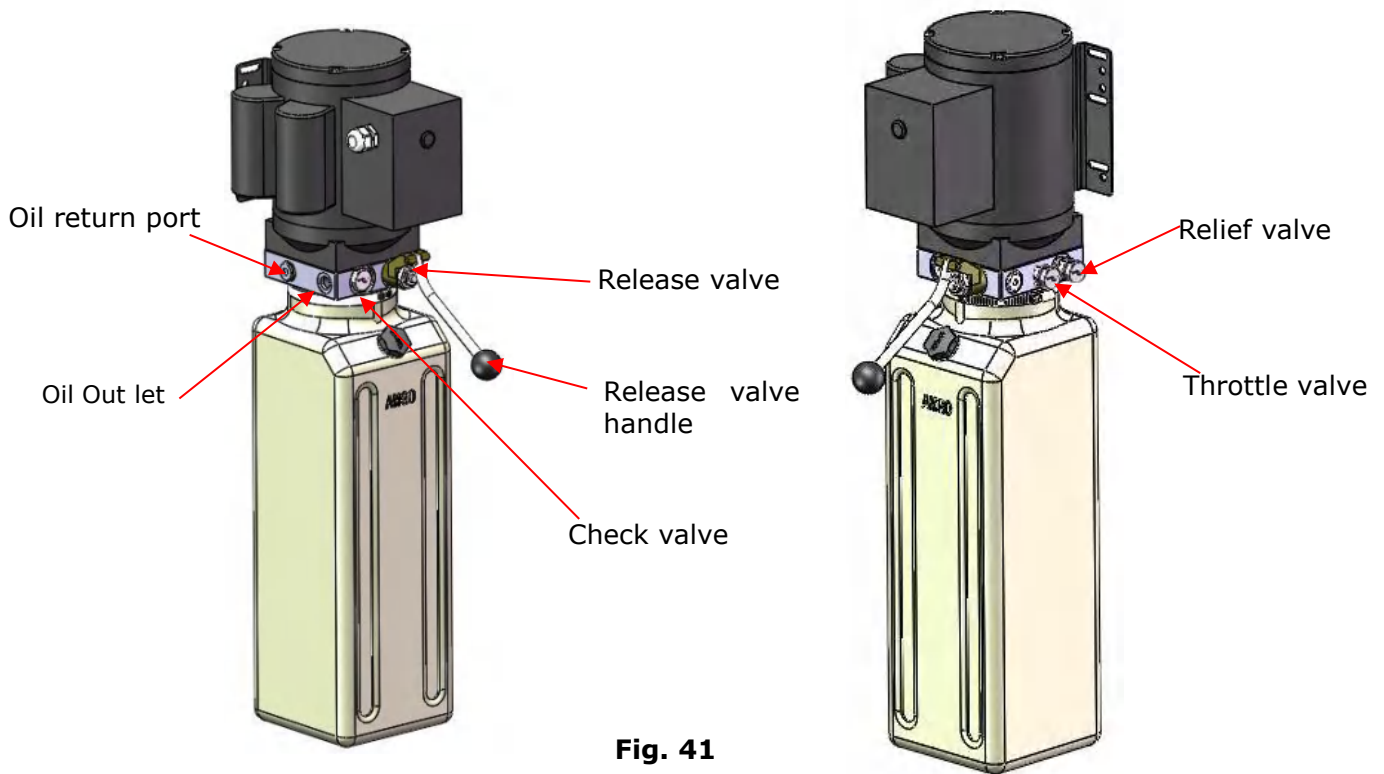


Fig. 41

V. TEST RUN

1. Adjustment of sync cable (See Fig. 42)

Use wrench to hold the cable fitting, meanwhile using ratchet spanner to tighten the cable nut until the two sync cables are adjusted to a certain tension force and are consistent. If the carriage on both sides do not run synchronously when the lift rises/falls, tighten the cable nut on the lower carriage until the lift can rise and fall synchronously.

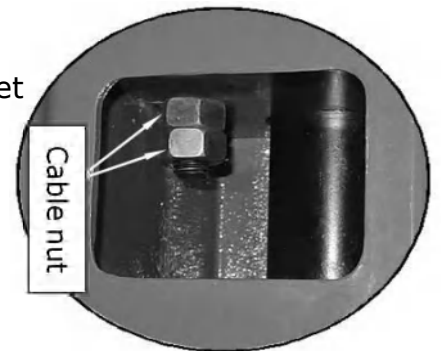


Fig. 42

2. Adjust safety cable

Lift both carriages and lock them at the same height, strain the lock release cable and then release a little, finally tighten the cable nuts. Ensure that the safety device can always be locked and unlocked properly. At last, install the cover of the safety device.

3. Adjust the lowering speed

If necessary, you can adjust the lower speed of the lift by turning the throttle valve clockwise to decrease it, or counterclockwise to increase the lower speed.

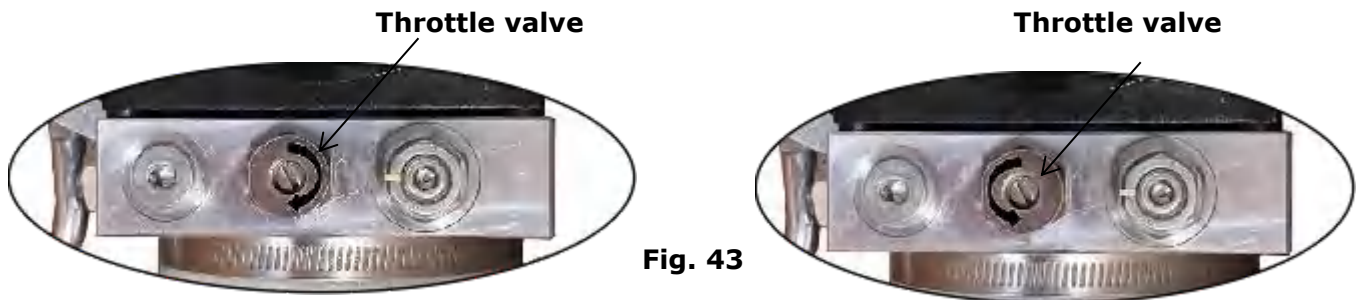


Fig. 43

Clockwise to decrease the lowering speed

Counterclockwise to increase lowering speed.

4. Test with load

A test with load should be conducted after the above adjustments have been completed. Run the lift at low level several times first, ensure that both side safety locks can lock and unlock in synchronization. When there is no other abnormal phenomenon, run the whole process. Repeat the above adjustment if there is any abnormal phenomenon.

Hydraulic Schematic Diagram

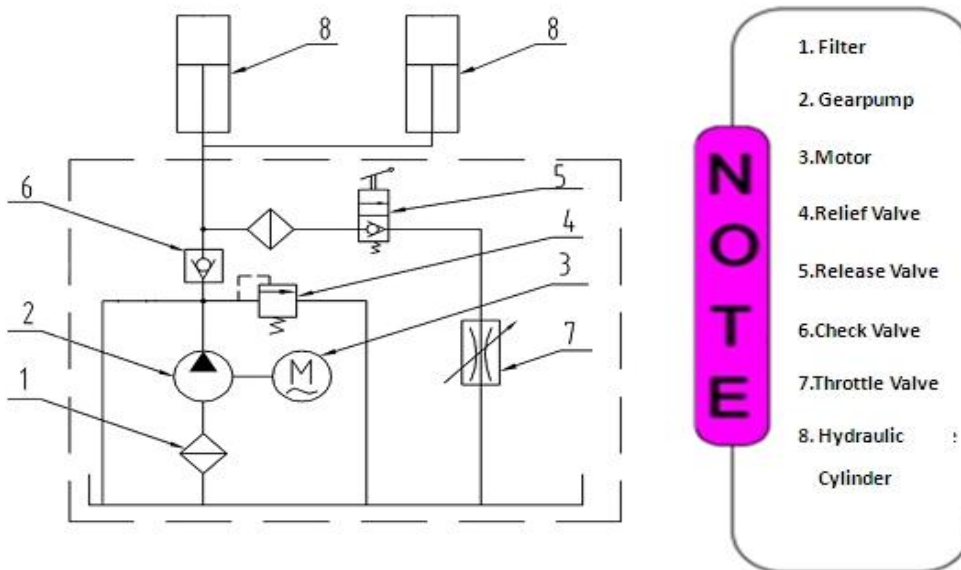


Fig. 44

⚠ WARNING Do not lift vehicles that exceed the rated capacity of the lift. Please do not release the safety handle until the lift safety lock is locked. Only trained personnel are authorized to operate the lift.

VI. OPERATION INSTRUCTIONS

Please read the safety tips carefully before operating the lift

To lift vehicle


1. Keep operation site clean;
2. Lower the lifting arm to the shortest position;
3. Retract the lifting arm to the shortest position;
4. Open lifting arms out to the sides;
5. Move the vehicle between columns, the curved arm of the lift is front;
6. Move the lifting arms to the vehicle's lifting point;


ATTENTION: Use the extension adapters provided by the AMGO manufacturer. Swing the lifting arms under the vehicle, lift the vehicle lifting points as recommend by the vehicle manufacturer. If necessary, use the stackable extension adapter or optional saddle adapter to ensure good contact.

7. Push **UP** button until the lifting pads contact underside of vehicle totally and recheck lifting points;
8. Continue to raise the lift slowly, ensure the balance of vehicle, lift the vehicle to the desired height, release the **UP** button;
9. Press the release handle on power unit to lower the lift to the safety lock position.
The vehicle cannot be repaired unless safety in lock position.

To lower vehicle

1. Clear obstructions around and under the lift and keep people away from the lift;
2. Push **UP** button to raise the vehicle slightly, and then unlock the safety device, lower vehicle by pushing release handle on the power unit.
3. Swing the lifting arms to both sides and retract the lifting arm to the shortest position;
4. Drive away the vehicle.

 **WARNING** It is unsafe to work when the lift without locking at safety device after it has been raised. The vehicle may fall, potentially causing damage the vehicle and lift, even injury or death to someone nearby.

 **DANGER** When using the lifting points on the chassis recommended by the vehicle manufacturer, be sure to follow the instructions carefully. If you don't, the vehicle can become unstable and fall, which can damage the vehicle and lift, injure or even kill anyone under the vehicle.

VII. MAINTENANCE SCHEDULE

Monthly:

1. Tighten the anchor bolts with to 150 Nm torque force;
2. Check all fittings, bolts and pins to ensure proper connections;
3. Lubricate cable and slider with lubricant;
4. Make a visual inspection of all oil hoses/lines for possible wear or leakage;
5. Check safety device and make sure proper condition;
6. Lubricate all rollers and pins with 90Wt gear oil.

Note: All anchor bolts should take full torque. If any of the bolts do not function for any reason, DO NOT use the lift until the bolt has been replaced.

Every six months:

1. Make a visual inspection of all moving parts for possible wear, interference or damage;
2. Check and adjust as necessary, equalizer tension of the sync cables to insure level lifting;
3. Check columns for plumbness;
4. Check Rubber Pads and replace as necessary;
5. Check Safety device and make sure proper condition;
6. Check hydraulic oil level of power unit.
7. Check the engagement of moon gear and arm lock.

Oil cylinder maintenance:

In order to extend the service life of the oil cylinder, please operate according to the following requirements.

1. Recommend to use N46 anti-wear hydraulic oil.
2. The hydraulic oil of the lifts should be replaced regularly during using. Replace the hydraulic oil 3 months after the first installation, Replace the hydraulic oil once a year afterwards.
3. Make at least one full trip raising and lowering per day. For exhausting the air from the system, which could effectively avoid the corrosion of the cylinder and damage to the seals caused by presence of air or water in the system.
4. Protect the outer surface of the oil cylinder's piston rod from bumping and scratching, and timely clean up the debris on the oil cylinder dust-ring and the piston rod.

VIII. TROUBLE SHOOTING

TROUBLE	CAUSE	REMEDY
Motor does not run	<ol style="list-style-type: none"> 1. Start button does not work 2. Wiring connections are not in good condition 3. Motor burned out 4. AC contactor in damage 	<ol style="list-style-type: none"> 1. Replace button 2. Repair all wiring connections 3. Repair or replace motor 4. Repair or replace
Motor runs but the lift is not raised	<ol style="list-style-type: none"> 1. Gear pump out of operation 2. Release valve in damage 3. Relief valve or check valve in damage 4. Low oil level 	<ol style="list-style-type: none"> 1. Repair or replace 2. Repair or replace 3. Repair or replace 4. Fill tank
Lift does not stay up	<ol style="list-style-type: none"> 1. Release valve out of work 2. Relief valve or check valve leakage 3. Cylinder or fittings leaks 	Repair or replace
Lift raises slowly	<ol style="list-style-type: none"> 1. Hydraulic System is jammed 2. Motor running on low voltage 3. Oil mixed with air 4. Gear Pump leaks 5. Overload lifting 	<ol style="list-style-type: none"> 1. Clean the Hydraulic System 2. Check electrical system 3. Fill tank 4. Repair or replace 5. Check load
Lift cannot lower	<ol style="list-style-type: none"> 1. Safety devices are locking. 2. Release valve in damage 3. Safety cable broken 4. Oil system is jammed 	<ol style="list-style-type: none"> 1. Release the safety devices 2. Repair or replace 3. Replace 4. Clean the oil system

⚠️ WARNING A lift would be dangerous if operated by inexperienced or distracted operators. Operators should be fully aware that lifting a vehicle is a potentially life-threatening operation, especially if ignoring the mandatory safety precautions.

IX. CAR LIFT SAFETY TIPS

Post these safety tips in a place where you can always alert the operator. Please reference to the lift manufacturer' s manual for specific information about the lift.

1. Check the lift daily. If the machine breaks down or has damaged parts, do not operate, and use the parts of original equipment to repair.
2. Do not overload the lift. The rated weight of the manufacturer design is indicated on the label of the lift.
3. Position control of the vehicle and operation of the lift can only be done by a trained and authorized person.
4. You can not lift a car with people inside. When the lift is working, the customer or other people should not be around the machine.
5. Keep the place around the lift clear of obstacles, lubricants, grease, garbage and other debris for a long time.
6. Before driving the car into the lift, put the lifting arm and rubber pad in the proper position to ensure barrier-free space. Do not hit or run over the lift arm and rubber pad of the lift, otherwise it will cause damage to the lift machine or the car.
7. Rise the lift to the required height for operation. Note, if you are working under a car, raise the lift high enough and make sure the safety device has locked.
8. Note, removing(or installing) parts from a car can cause a sudden shift of gravity that is unstable for the raised car. Reference to the car manufacturer' s service manual as a recommended procedure when removing parts from the car.
9. Before lower the lift , make sure that the tool tray, tool rack, etc. are removed from under the car. Open the lock before lowering the lift.
10. Before removing the car from the lift, put the lifting arm and rubber pad in place to ensure an unobstructed exit.

X. LIFT DISPOSAL

When the car lift cannot meet the requirements for normal use and needs to be disposed, please follow local laws and regulations.



Address:

SC Division: 1931 Joe Rogers Jr Blvd, Manning, SC 29102, USA

TX Division: 4310 Adler Dr., Suite #200, Dallas, TX 75211, USA

<http://www.amgohyd.com>

Manual No.: 72227408
Revision Date: 2025/11