

**XL-10F**

FULL RISE SCISSORS  
**FLUSH-MOUNT LIFT**

*Built with heavy-duty construction, the XL-10F Lift boasts a 10,000lbs capacity and features dual extendable platforms that accommodate a wide range of wheelbases from passenger cars and pickup trucks to light-duty commercial vehicles. It also comes standard with a photocell device and an automatic safety stop mechanism, making it the ideal solution for routine maintenance operations.*



**Main Features**

- ✓ 10,000lbs capacity, heavy-duty design;
- ✓ The flush-mount design provides an unobstructed shop floor;
- ✓ Full rise design ensures generous workspace beneath the vehicle;
- ✓ Dual extendable platforms enhance the compatibility for various wheelbases;
- ✓ Mechanic locking system with air-release;
- ✓ Electrical hydraulic power system with control cabinet;
- ✓ Photocell device ensures the absolute synchronization ;
- ✓ Automatic safety stop device comes standard;
- ✓ 3" rubber pads come standard.

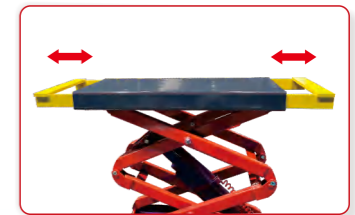

Dual extendable platforms enhance the compatibility for various wheelbases.



Mechanical automatic safety device, Air-operated safety release. Free access allowed from either side.



Optional: Leveling bar. Kits No.: SX003



3" Rubber pads come as standard.



Hydraulic synchronization system. Photocell detection and protection.

**SPECIFICATIONS**

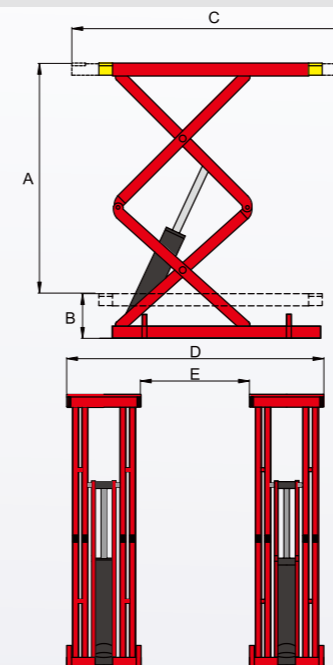

Model	XL-10F	
Lifting Capacity	10,000lbs	
Lifting Time	49 S	
Max. Lifting Height	A	75"
Max. Lock Height		72 5/8"
Minimum Height	B	13 3/4"
Runway Length	C	65 1/8" ~ 80 5/16"
Overall Width	D	74 13/16"
Width Between Runway	E	31 1/2"
Gross Weight	1,903 lbs	
Motor	2.0HP,220V/60Hz,single phase	