

Installation And Service Manual

FOUR POST LIFT

Model: PRO-40, PRO-40E

Cargo Claims

If there is any missing or damaged product during transportation, the buyer must notate on the shipping paperwork or refuse the shipment. NOTATE ALL DAMAGE OR REFUSE DAMAGED SHIPMENT!



DANGER

Read the entire contents of this manual before using this product. Failure to follow instructions and safety precautions could result in serious injury or even death. Make sure all other operators also read this manual. Keep this manual near the machine so that it can be seen by all users. By proceeding with installation and operation, you agree that you are fully understand the contents of this manual and take full responsibility for the use of the product.

CONTENTS

Profile	1
Important Safety Instructions.....	3
I.Product Features And Specifications	5
II.Installation Requirement	6
III.Installation Steps.....	8
IV.Exploded View	27
V.Test Run	33
VI.Operation Instructions.....	34
VII.Maintenance Schedule	34
VIII.Trouble Shooting	36
IX.Car Lift Safety Tips.....	37
X.Lift Disposal.....	37

Explanation of the safety warning symbols used in this manual

-  DANGER Risk of death or injury
-  WARNING Dangerous or unsafe practices that may result in death or injury
-  CAUTION Dangerous or unsafe practices that may result in personal injury, product damage or property damage
- ATTENTION Conditions that may result in damage to products or property

PROFILE

The four post lift is a commonly used vehicle repair and maintenance tool that uses a hydraulic or electric system that can lift the car up to a certain height so that the vehicle can be placed in a suitable position for inspection and repair. Car lifts can be divided into pneumatic and electric, which have the characteristics of safe and reliable, simple structure and quick installation.

This instruction manual is specially prepared for you. Your new lift is the product of over a decade of continuous research, testing and development and is the most technologically advanced lift on the market today.

Please make sure to read through this manual before operating the lift.

Record the information on the nameplate label here:

Model No.: _____

Serial No.: _____

Manufacturer date: _____

WARRANTY

The warranty period for the steel structure part of new car lift is 5 years; hydraulic components, bronze bushings, slider blocks and plastic parts are warranty for 3 years; electrical components and cables are warranty for 2 years. Rubber pads are without warranty. During the warranty period, the manufacturer will repair or replace the defective parts free of charge including shipping costs.

This warranty does not cover damage caused by normal wear and tear, improper use, damage in transit, or damage caused by lack of maintenance.

This warranty is unique and supersedes what is expressed and implied in all other warranties.

The manufacturer shall not be liable for any particular, indirect or accidental damage resulting in breach of or delay in the execution of the warranty. The manufacturer reserves the right to design and improve the product and has no obligation to make notice of the changes in advance.

The product warranty based on the above clause is based on the model number and serial number of the equipment. This information must be provided in conjunction with all warranty information at the time of service and warranty.

SAFETY WARNING LABEL

⚠ WARNING ⚠



Please read the user manual before operation.



Never allow unauthorized personnel near the equipment



Always wear protective shoes and mind your feet during lowering



Please mind your hands during operation.



Keep away from the equipment during operation



Use wheel chock to avoid vehicle moving.



Please lock the safety device before repairing the vehicle.



Please run away quickly from any falling objects.

PLEASE READ THE PRECAUTIONS CAREFULLY

No.71030135

IMPORTANT SAFETY INSTRUCTIONS

In order to properly maintain your product and ensure operator safety, it is the responsibility of the product owner to read and follow these instructions!

1. Ensure product installation full complies with all applicable local and national rules, ordinances and regulations;
2. Ensure that all operators are properly trained, know how to operate the unit safely, and are properly supervised;
3. Do not operate the lift until you are sure all parts are in place and operating correctly;
4. Keep your hands and feet away from the machine. Keep hands and feet away from any moving parts. Keep your feet away from the lift as it descends and avoid pressing on pointed objects;
5. Keep the work area clean. A cluttered workspace can lead to injuries;
6. The machine is only approved for indoor installation and use. Outdoor installation is prohibited;
7. Only trained operators are allowed to handle the lift machine. All untrained persons must stay away from the workplace. Never allow untrained persons to handle or operate the machine;
8. Use the lift properly. Use the lift in the correct way;
9. Warning! Keep persons and objects from the lift when lifting the a vehicle;
10. If the vehicle is at risk of falling, make sure no one is around the lift;
11. Before preparing to approach or service the vehicle, ensure that the safety device is in effect;
12. Dress appropriately when operating machines, and consider wearing non-slip steel-toe shoes for safety;
13. Beware of electric shock. In order to protect the operator from electric shock, the lift in use must be grounded. Do not connect the green wire to the terminal. This is the ground wire;
14. Danger! The power supply used in this type of lift has high voltage. Please disconnect the power supply before any circuit repair. Unplug in case the power supply is accidentally switched on during maintenance;
15. Warning! There is a risk of explosion. There are parts in the equipment that produce arc light and spark. Do not operate near flammable gas. This machine should not be placed in the lounge or basement;
16. Maintain with care. Keep the machine clean for better and safer operation. Perform proper lubrication and maintenance procedures according to the manual. Keep handles or buttons clean, dry, and free of oil;
17. Stay alert. Use common sense to observe what you are doing and stay alert;

18. Check for damaged parts. Check for adjustments to moving parts, damage to parts, or anything that may affect their operation. Do not use the machine if the parts are damaged;
19. Do not remove relevant safety parts from the machine. Do not use a lift if it is damaged or missing;
20. Operate the lift only at temperature between 5°C to 40°C (41°F to 104°F).

 **DANGER** Be very careful when installing, operating, maintaining or repairing this equipment. Failure to comply may result in property damage, product damage, injury or (in very rare cases) death. Ensure that only authorized personnel operate the equipment. All repairs must be carried out by an authorized technician. Do not modify the machine, this voids the warranty and increases the probability of personal injury or property damage. Ensure to read and follow this instructions on the label.

I. PRODUCT FEATURES AND SPECIFICATIONS

- Manual control system
- Mechanical self-lock and pneumatic safety release
- Manual hydraulic power system, cable-driven.
- Strengthen and Non-skid diamond platforms.
- Adjustable platform and adjustable safety lock ladders.
- Optional Jack: With Pneumatic hydraulic pump.

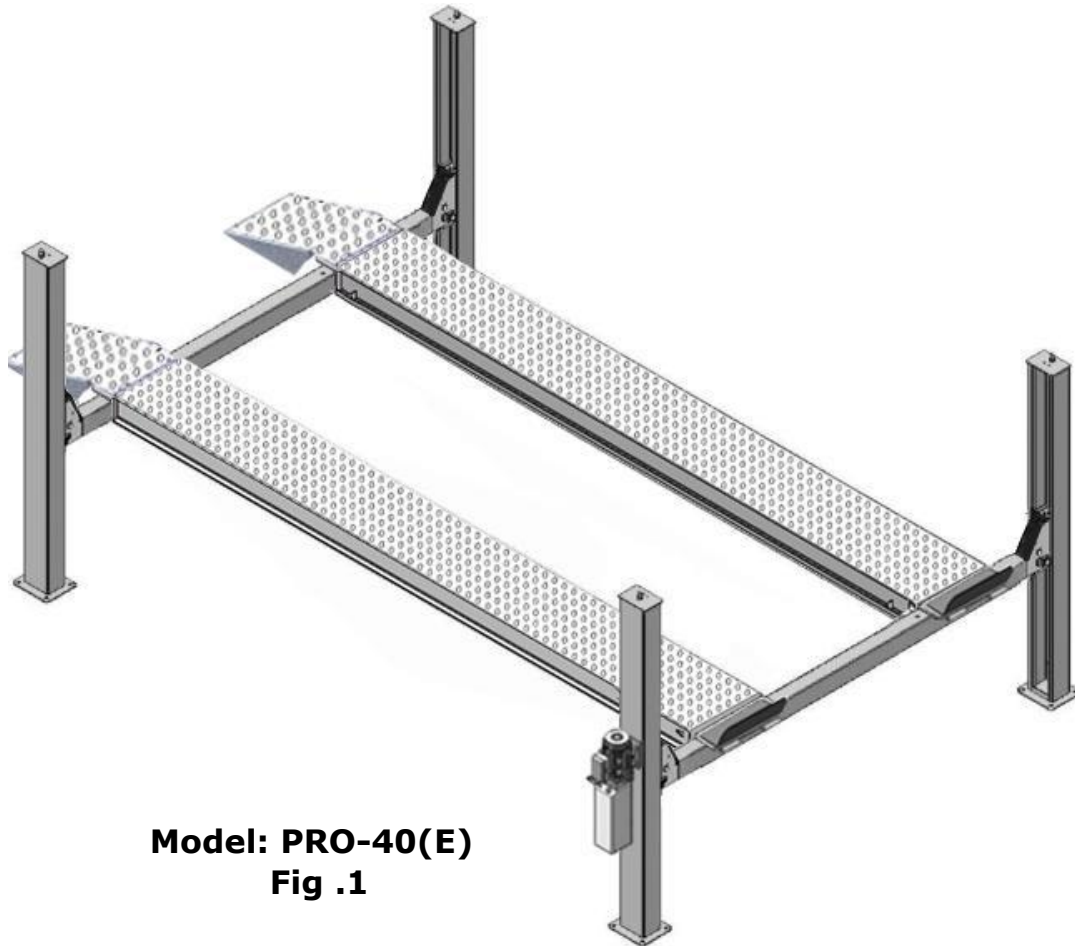

Model: PRO-40(E)
Fig .1

MODEL SPECIFICATIONS

Model	Lifting Capacity	Lifting Time	Overall Length (Inc. Ramps)	Overall Width	Width Between Columns	Lifting Height	Max Locking Height	Overall Height
PRO-40	40,000lbs	183s	366 1/8"	151 1/2"	133 15/16"	75 3/8"	72 3/16"	92"
PRO-40E	40,000lbs	183s	425 3/16"	151 1/2"	133 15/16"	75 3/8"	72 3/16"	92"

Model	Min. Height	Max. Underneath height	Max Locking underneath height	Drive-thru dimension	Width between runways		Outside edge of runways		Motor
					Wide	Narrow	Wide	Narrow	
PRO-40	10 3/8"	66 5/16"	63 3/16"	119 13/16"	54 1/16"	46"	110"	101 7/8"	2.0HP
PRO-40E	10 3/8"	66 5/16"	63 3/16"	119 13/16"	54 1/16"	46"	110"	101 7/8"	2.0HP

II. INSTALLATION REQUIREMEN A TOOLS REQUIRED

↳ Rotary Hammer Drill ($\Phi 3/4$)



↳ Hammer



↳ Level Bar



↳ English Spanner (12")



↳ Wrench Set:

(10#, 12#, 13#, 14#, 17#, 19#, 24#, 30#)



↳ Ratchet Spanner With Socket (28#)



↳ Carpenter's Ink Marker



↳ Screw Sets



↳ Tape Measure (295-1/4")



↳ Pliers



↳ Lock Wrench



↳ Socket Head Wrench
(3#, 5#, 6#)



Fig. 2

B. Equipment storage and installation requirements.

- 1 . Store the equipment in a dry, non-moldy, non-flammable environment.
- 2 . The lift is generally approved for indoor installation and use. If need outdoor installation, the optional motor protect cover is required.
- 3 . When installing the device, take safety precautions according to the instructions to avoid device damage.
- 4 . During installation, all parts should be fastened to ensure the stability and smooth operation of the machine.
- 5 . After installation, the whole machine should be checked to make sure that every component is working properly.

C. SPECIFICATIONS OF CONCRETE (See Fig. 3)

Specifications of concrete must be adhered to the specification as following.

Failure to do so may result in lift and/or vehicle falling.

1. Concrete must be thickness 120mm minimum and without reinforcing steel bars, and must be dried completely before the installation.
2. Concrete must be in good condition and must be of test strength 210kg/cm² minimum.
3. Floors must be level and no cracks.

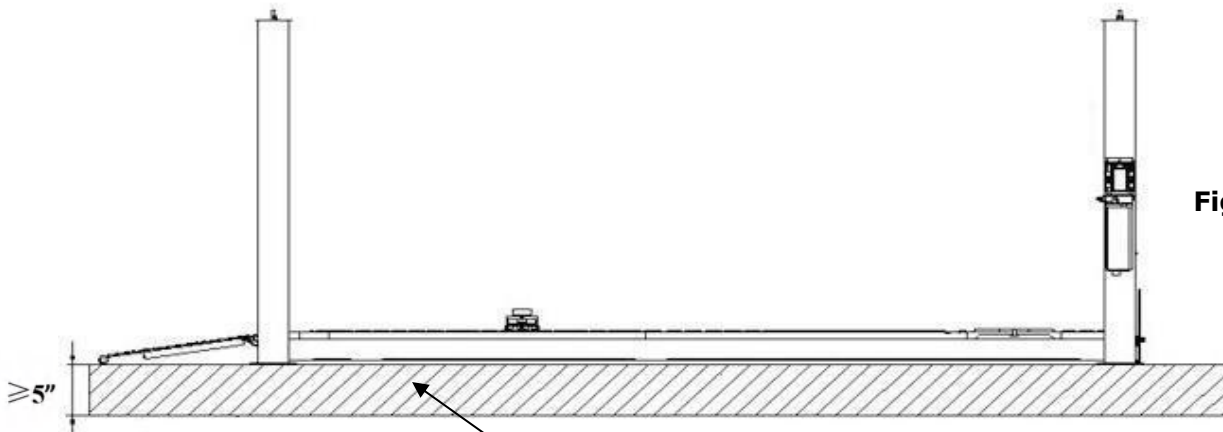

Fig. 3

D. AIR SUPPLY

Air pressure requirement: 0.8Mpa, Air line size $\Phi 8 * \Phi 6$.

E. POWER SUPPLY

1. You are required to use a licensed and qualified electrician for the installation process.
2. The electrical source must be 3.0HP minimum. The source cable size must be 12AWG and in good condition of contacting with floor.

⚠ DANGER All electrical wiring must be performed by a licensed and certified electrician. Attempting to connect the circuit without proper certification may result in damage to the lift or electrocution, resulting in serious injury or death.

III. STEPS OF INSTALLATION

A. Location of installation

Check and insure the installation location (concrete, layout, space size etc.) is suitable for lift installation.

B. Check the parts before assembly

1.The equipment should be unload and transfer by forklift. (See Fig.4)



Fig. 4

2.Received lift with hydraulic power unit (See Fig. 5).



Fig. 5

3. Open the outer packing ,check all the parts according to the parts list (See Fig. 6).

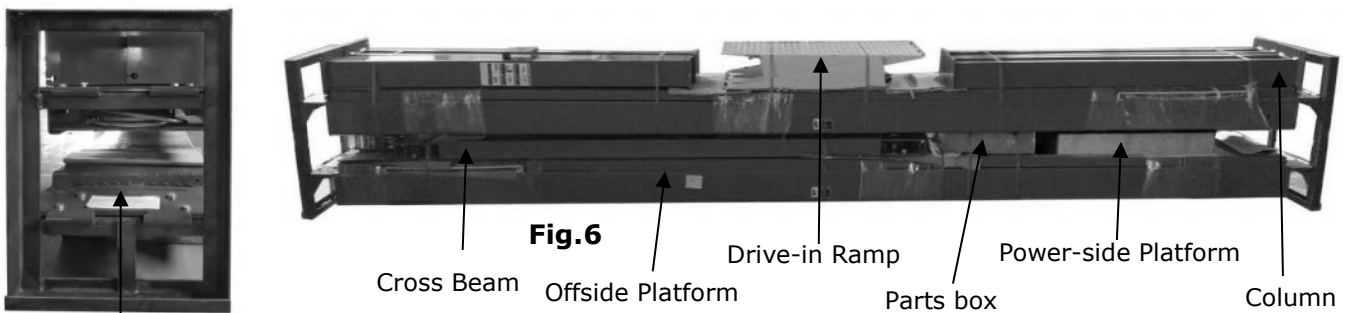

Shipment Parts List

4. Take off the Drive-in Ramps and Columns (See Fig.7).



Fig. 7

5. Loose the screws of the upper package stand ⇒ take off the offside platform ⇒ take out the parts inside the power side platform ⇒ then remove the package stand.
6. Move aside the parts and check the parts according to the shipment parts list (**See Fig. 8**).

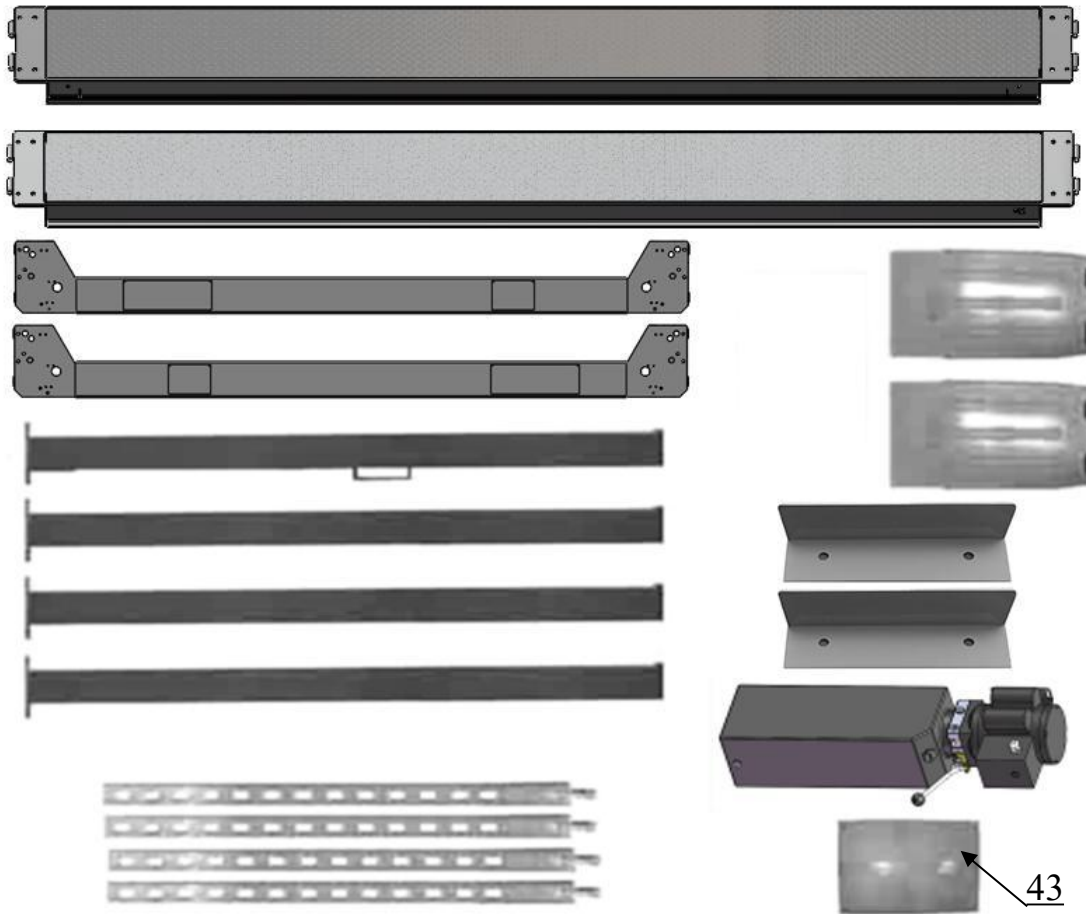

Fig.8

7. Open the parts box and check the parts according to the parts box list (**See Fig. 9**).



Fig. 9

C. Use a carpenter’s chalk line to establish installation layout , make sure the size is right and base is flat (**see Fig. 11**).

Note: Reserve space before and behind the installation site.

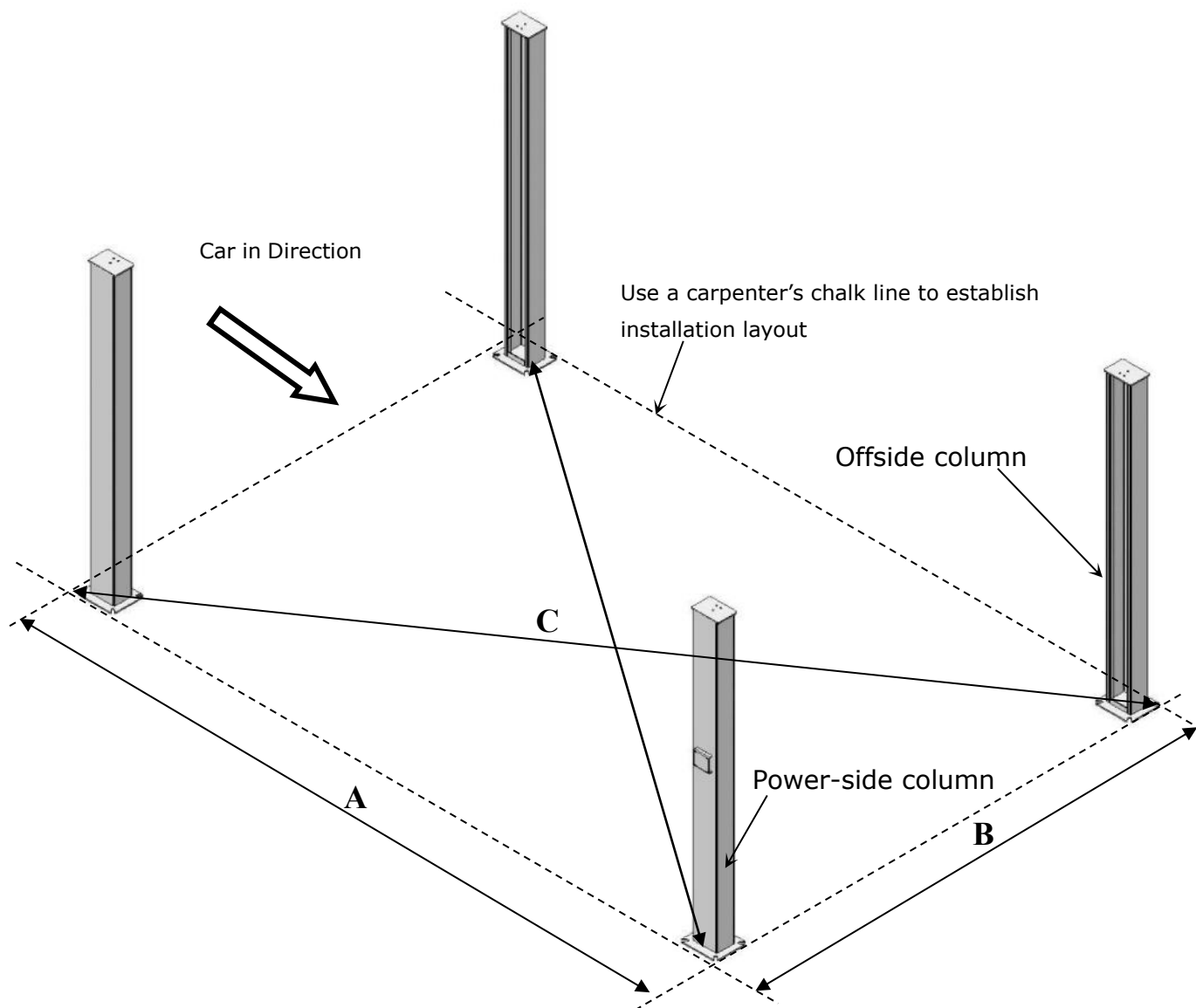

Fig. 11

Model	A	B	C
PRO-40	315 1/2" (8014mm)	151 1/2" (3848mm)	350" (8890mm)
PRO-40E	374 1/2" (9514mm)	151 1/2" (3848mm)	404 1/16" (10263mm)

D. Install cross beams (See Fig. 12).

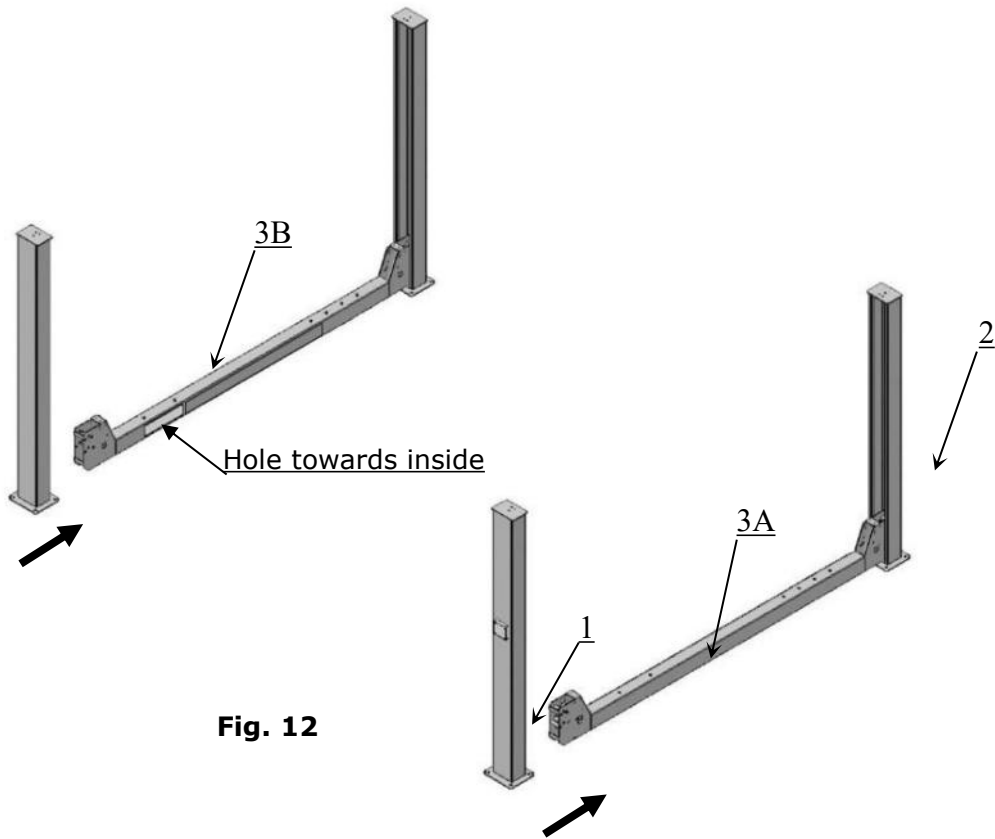

Fig. 12

E. Fix the anchor bolts

1. Prepare the anchor bolts (See Fig. 13).

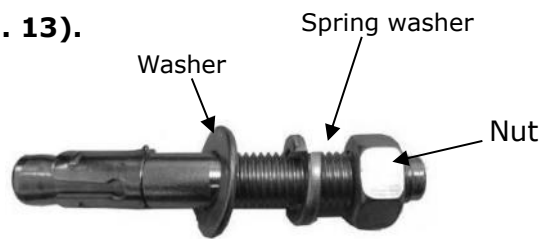

Fig. 13

2. Using the prescribed rotary hammer drill, and drill all the anchor holes and install the anchor bolts, do not tighten the anchor bolts first (See Fig. 14).

Note: Minimum embedment of anchors is 4-3/8" (110mm).

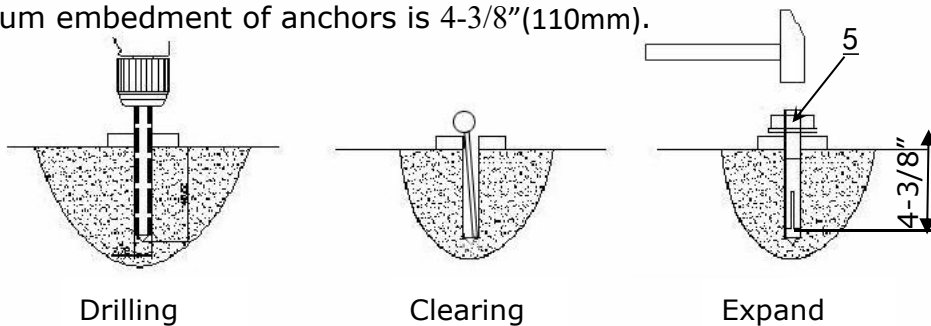
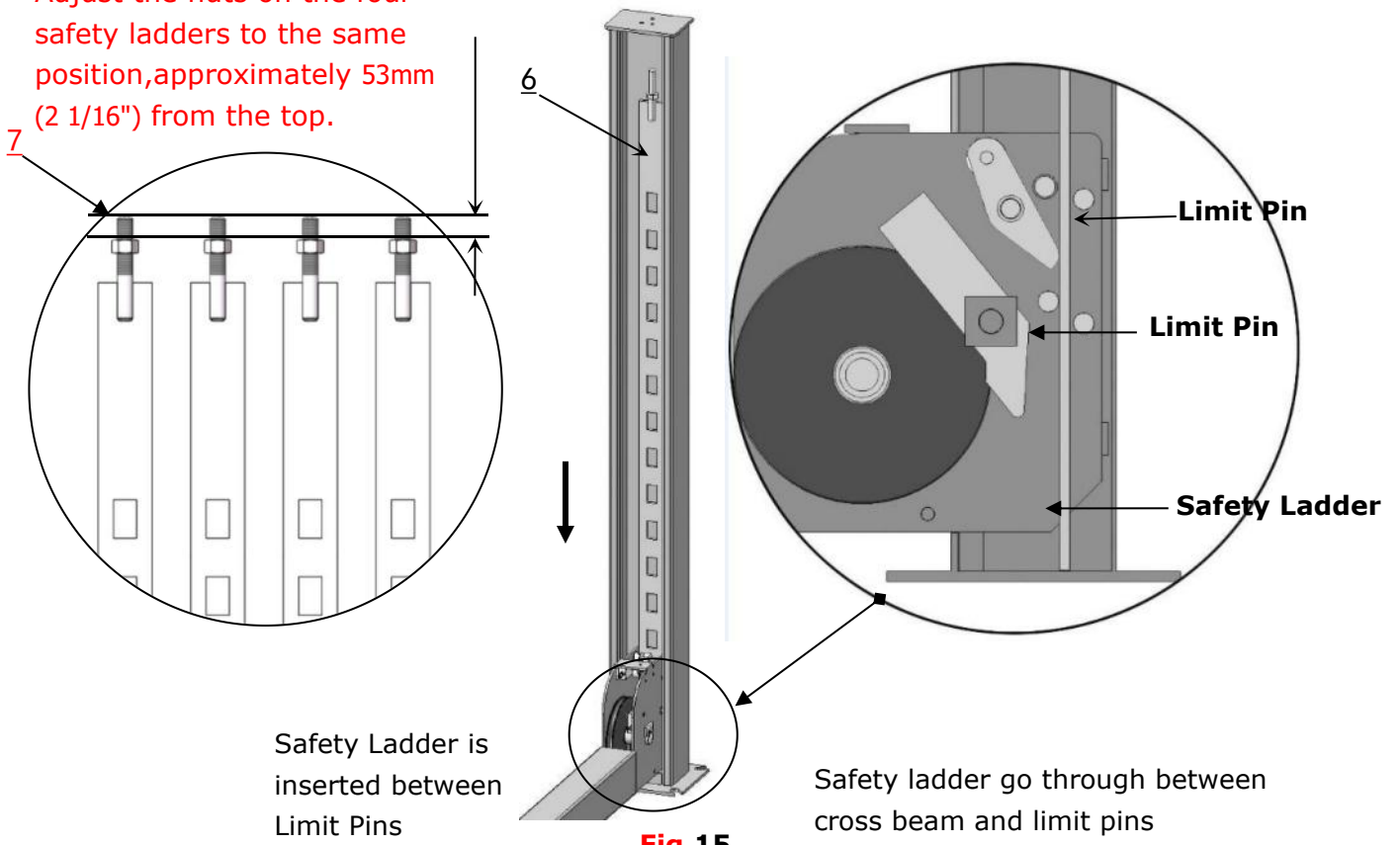

Fig. 14

F. Install the safety ladders

1. Adjust the nuts of the four safety ladders to the same position, and then install the safety ladders(See Fig. 15.)

Adjust the nuts on the four safety ladders to the same position, approximately 53mm (2 1/16") from the top.



2. Install safety ladders (See Fig. 16)

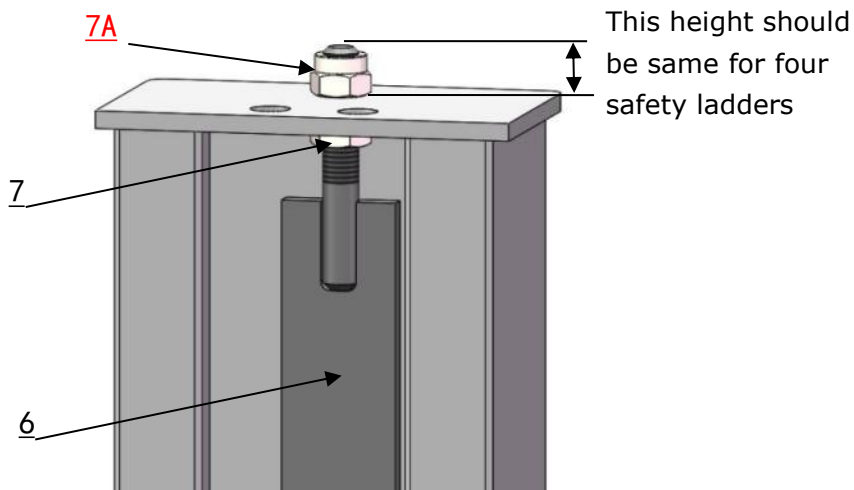

Safety ladder pass through the hole of the top plate and the self-locking nut is screwed on. The upper and lower nuts do not need to be tightened.

G. Put the Cross Beams at the same height (See Fig. 17).

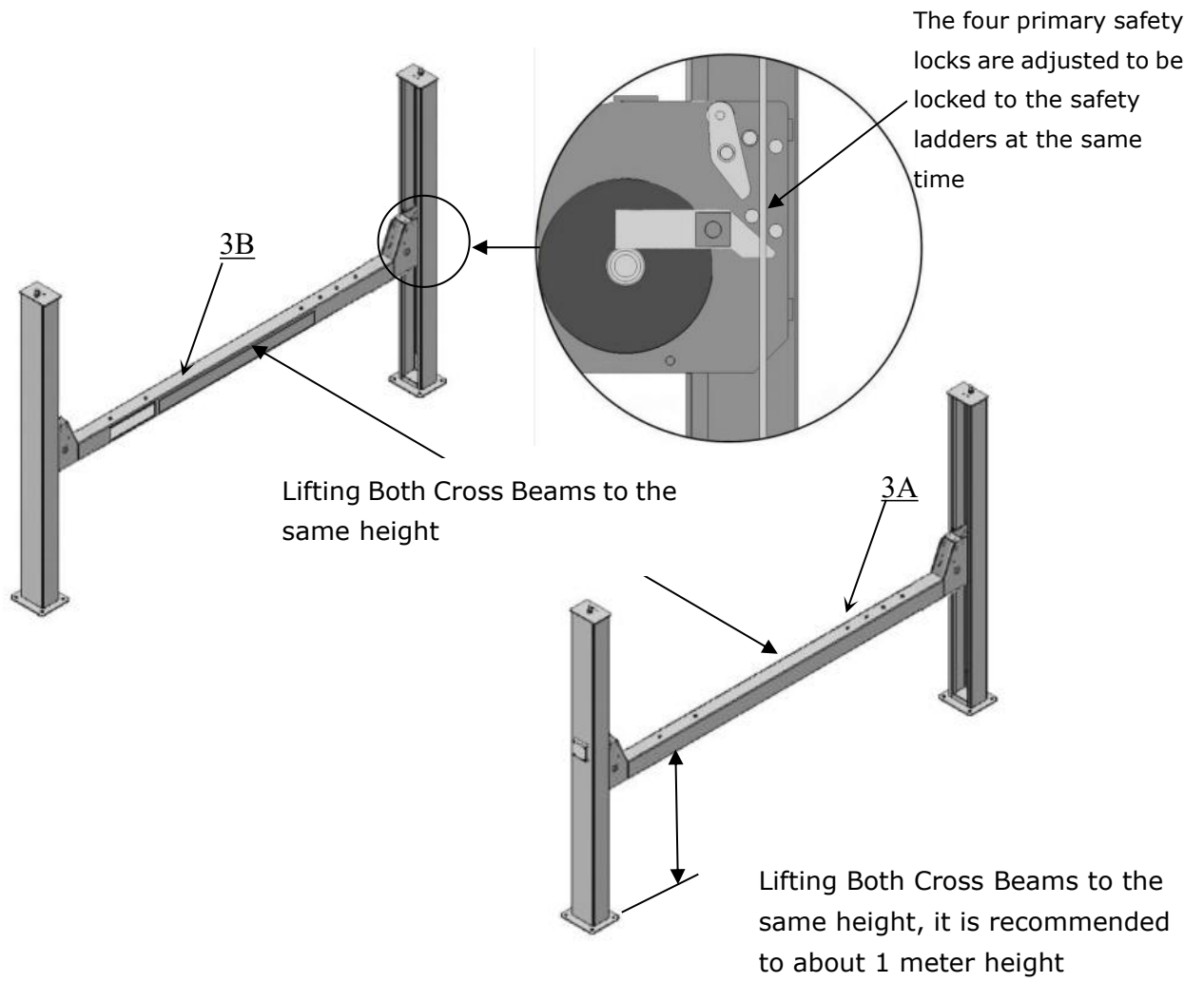
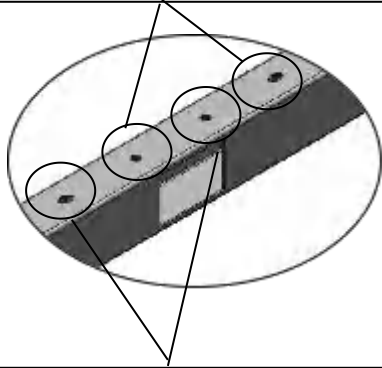

Fig. 17

H. Install power side platform.

1. Put the power-side platform upon the cross beams by fork lift or manual, offset the cross beams to the outside till the pulleys of both platforms can set up into the cross beam (See Fig.18, Fig.19), Install the power side platform and screw up the bolts (See Fig.20)

Off side platform mounting holes for wider installation



Off side platform mounting holes for narrow

Offset the Cross beam leaning outward.

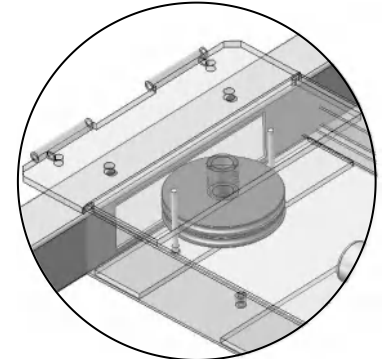
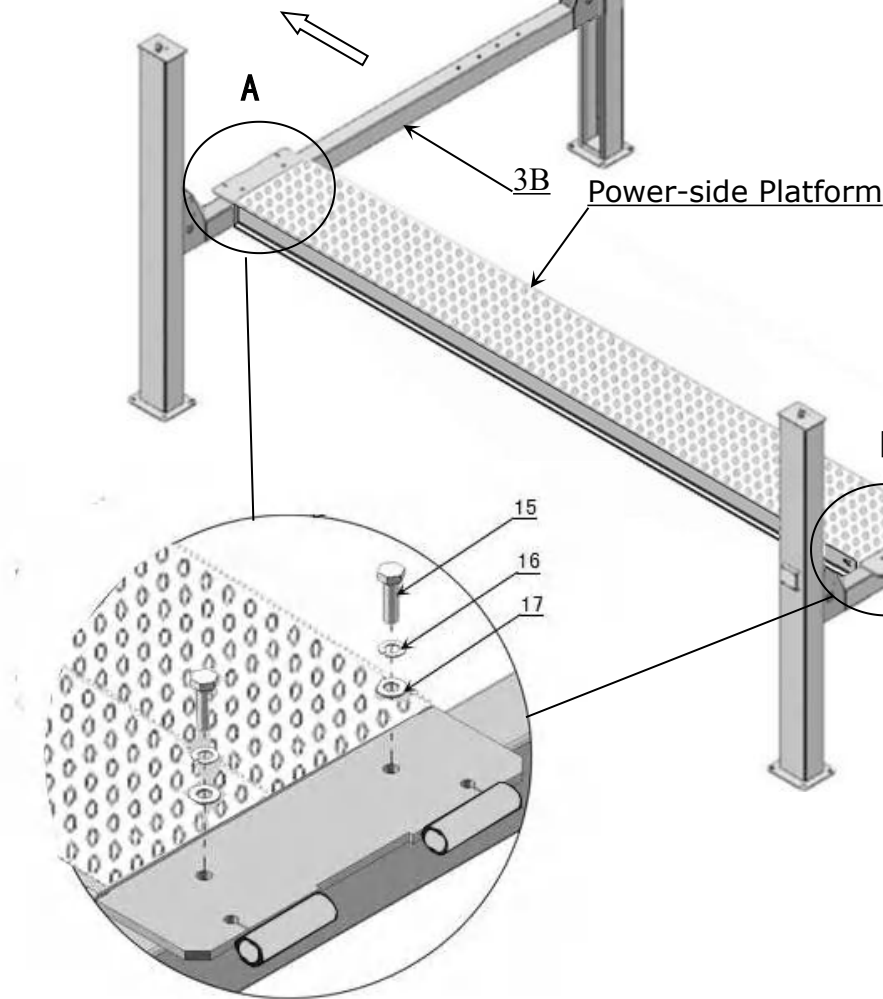

Assembly of 2 pulleys

A View
Fig.18

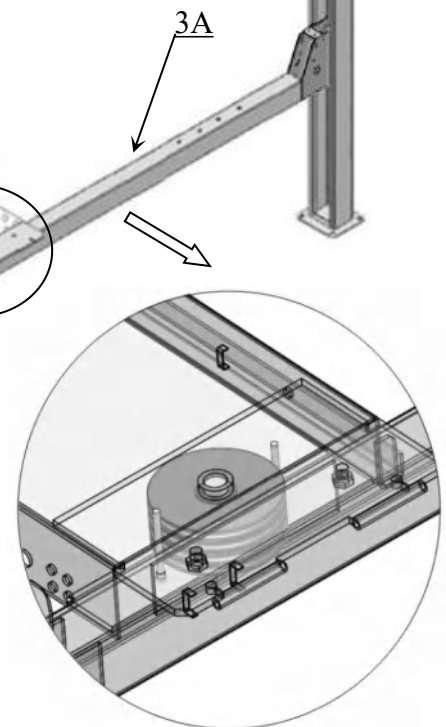

Assembly of 4 pulleys

B View
Fig.19

Install the power side platform with M30*60 hex bolt and screw up the bolts

Fig.20

2. In the same way, place the off side platform on cross beams, align the holes and tighten with bolts. Fig 21 for wider installation, Fig 22 for narrow installation.

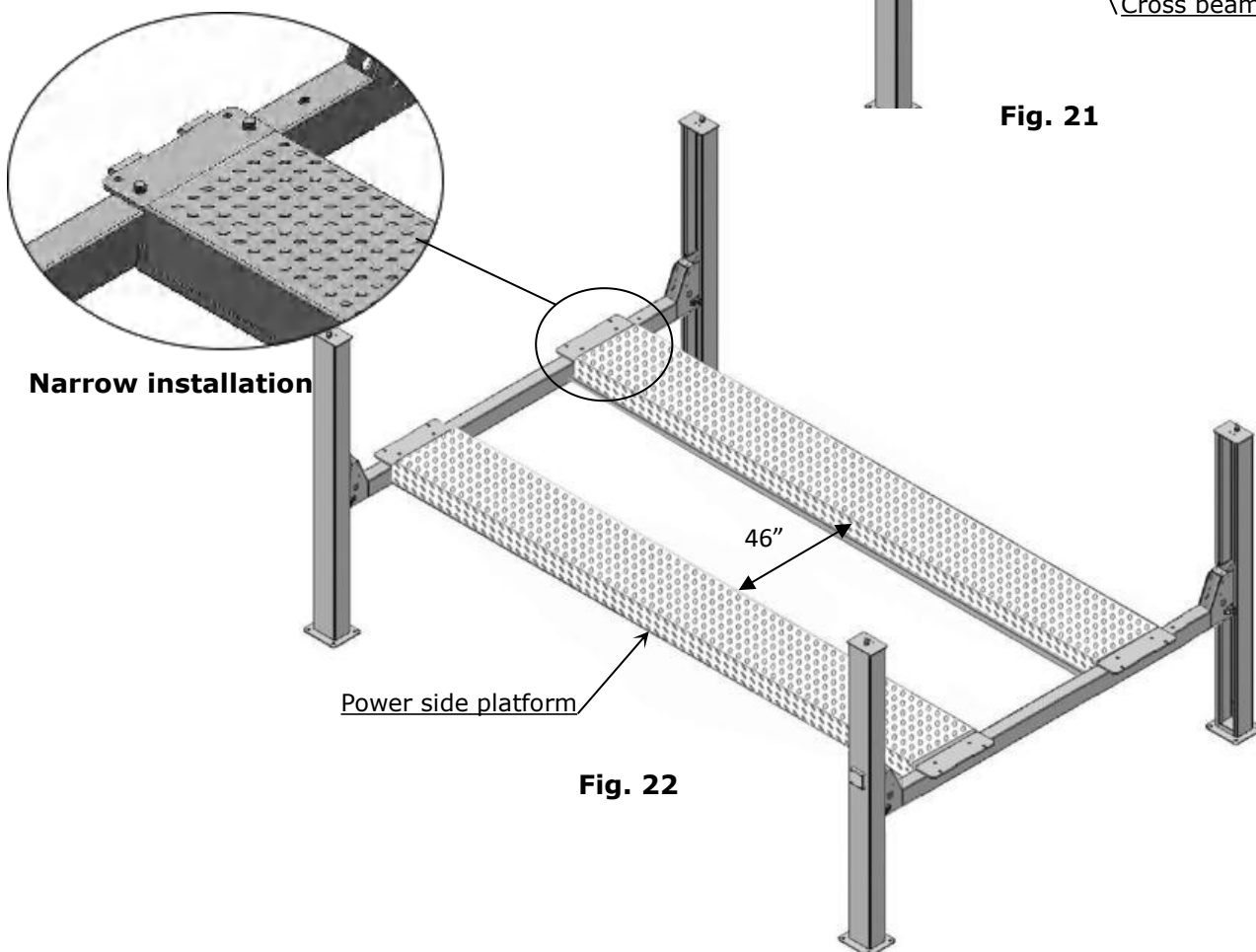
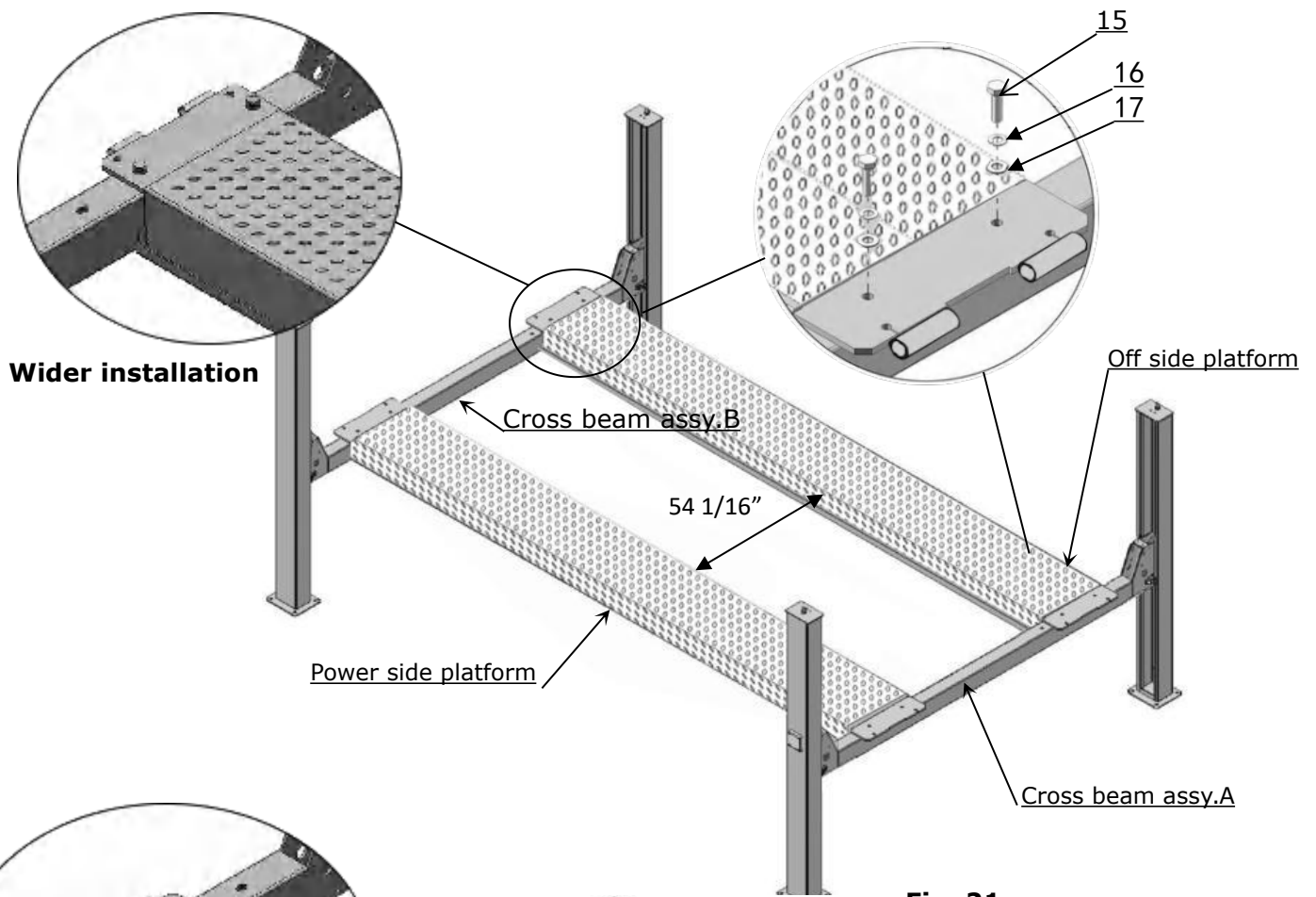

I. Assemble offside platform and slider block. (see **Fig.23**), check the vertical of columns with Level bar, adjust with the shims if not, and then tighten the anchor bolts (**See Fig. 24**)

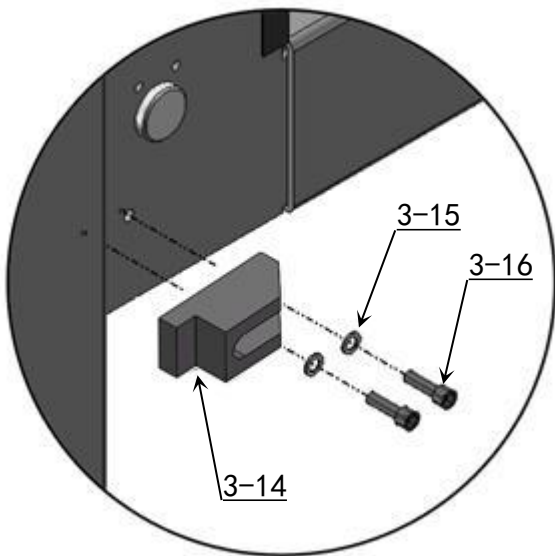
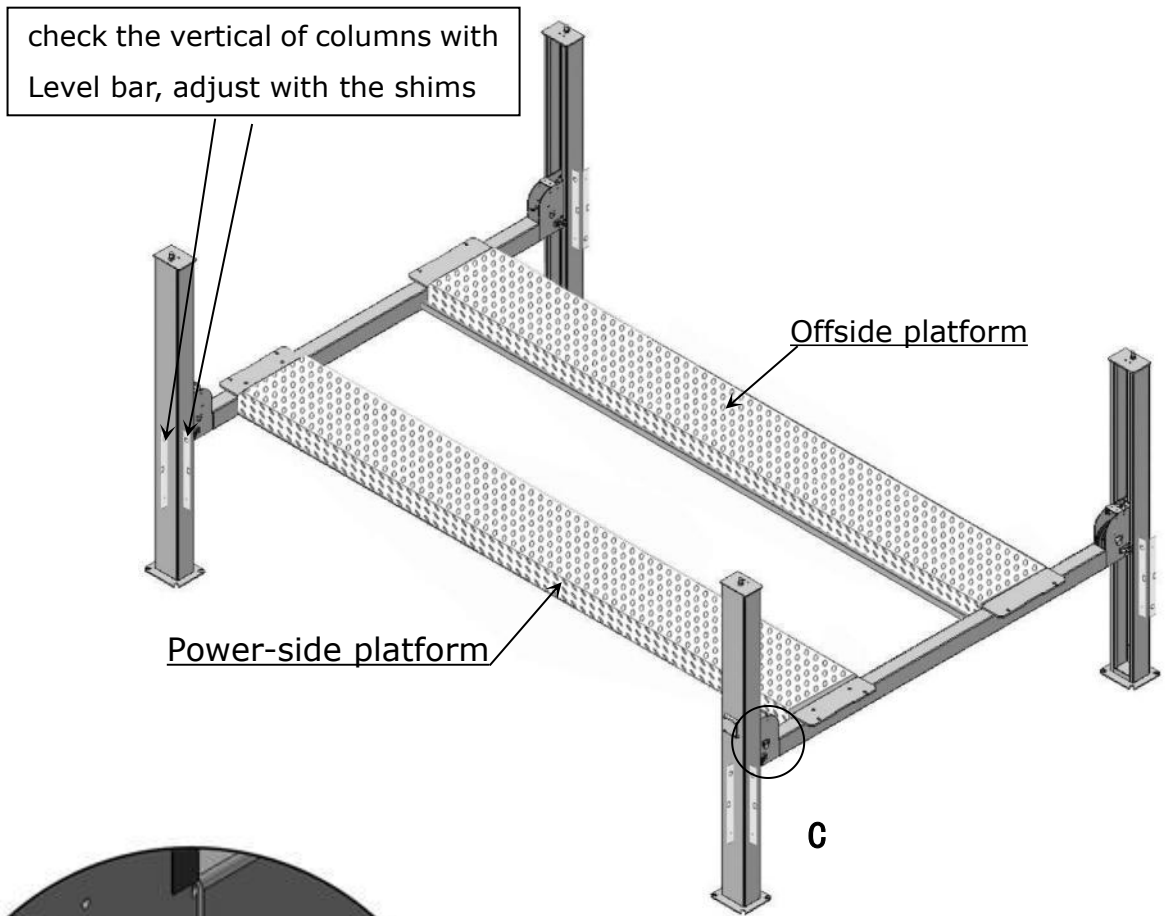

Install the slider block
C View
Fig 23

Note: Torque of Anchors is 150N·m.

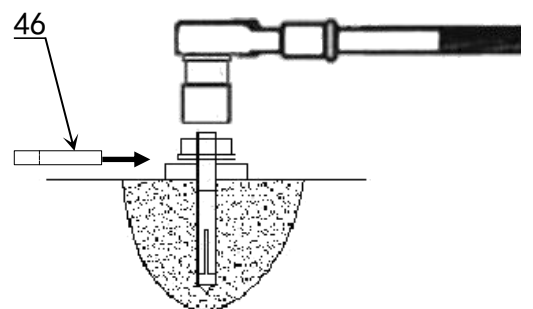

Using the ratchet spanner with socket to tighten the bolts

Fig. 24

J. Install cables (See Fig. 25)

1. Pass through the cables from the platform to the columns according to the number of the cables

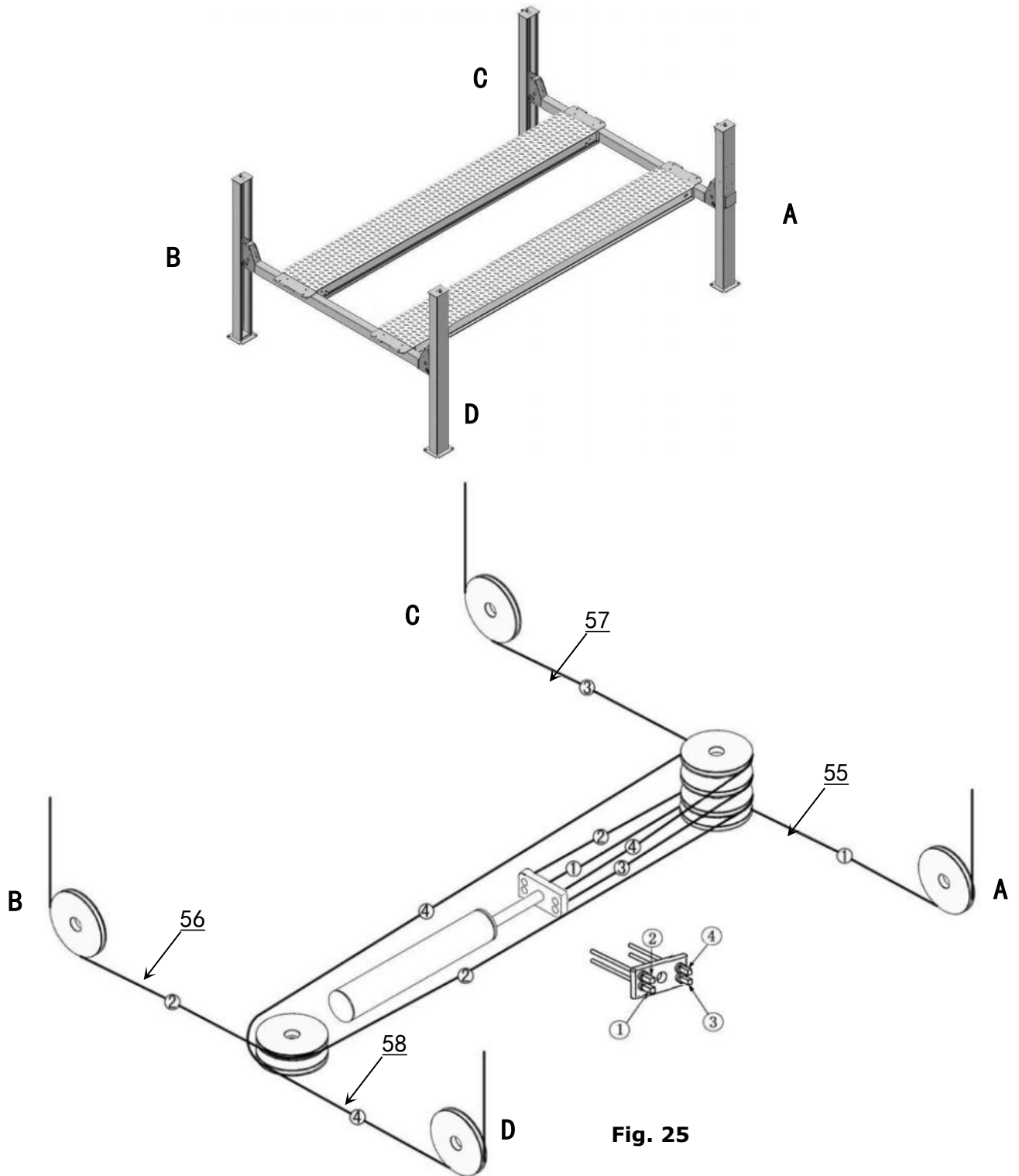
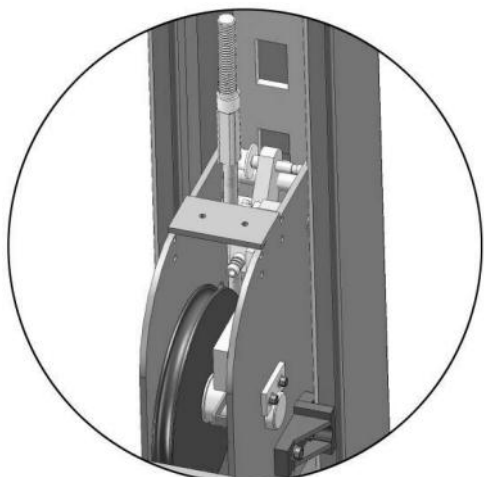

Fig. 25

No. / Cable	①	②	③	④
PRO-40	190 15/16"	576 3/4"	272 13/16"	494 15/16"
PRO-40E	249 13/16"	694 7/16"	331 13/16"	612 11/16"

2. The cable pass through the cross beam to top plate of columns and be screwed with cable nuts (See Fig. 26, Fig.27), then install cable limit pin (See Fig.28)



Cable pass through between the big pulley and tension pulley

D View
Fig.26

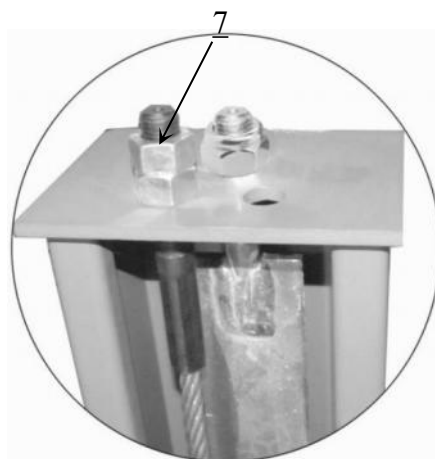

Cable pass through top plate and be screwed with cable nuts.

E View
Fig.27

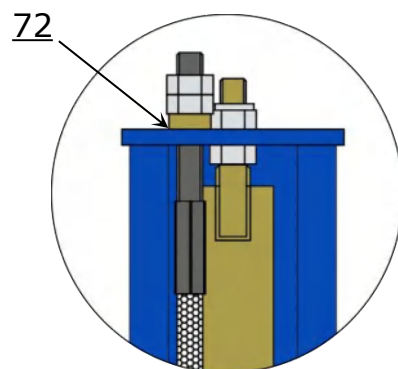
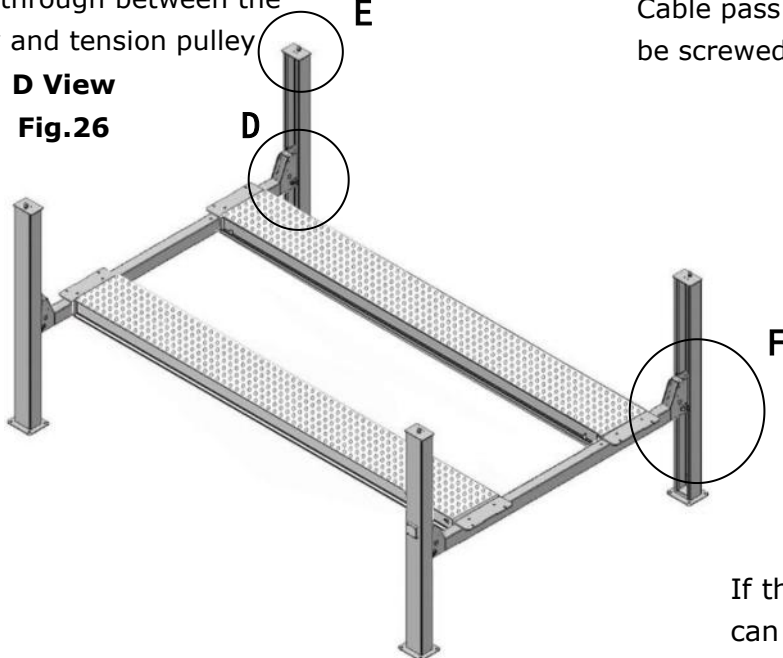

If the cable appears elongated, it can be adjusted by adding an adjusting sleeve under the nut.

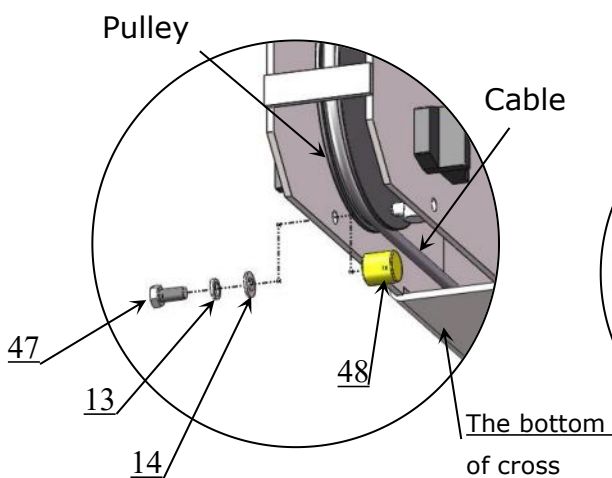

Install cable limit pin

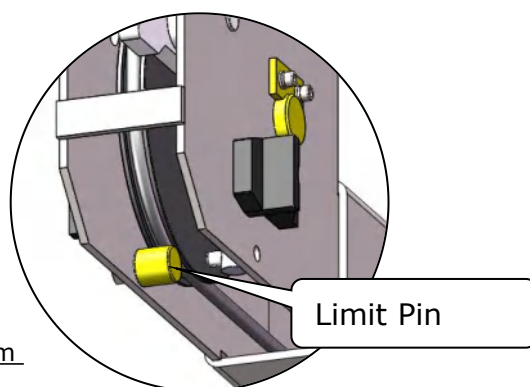

After installation

F View
Fig. 28

3. Illustration for platform cables (See Fig. 29, Fig.30, Fig.31)

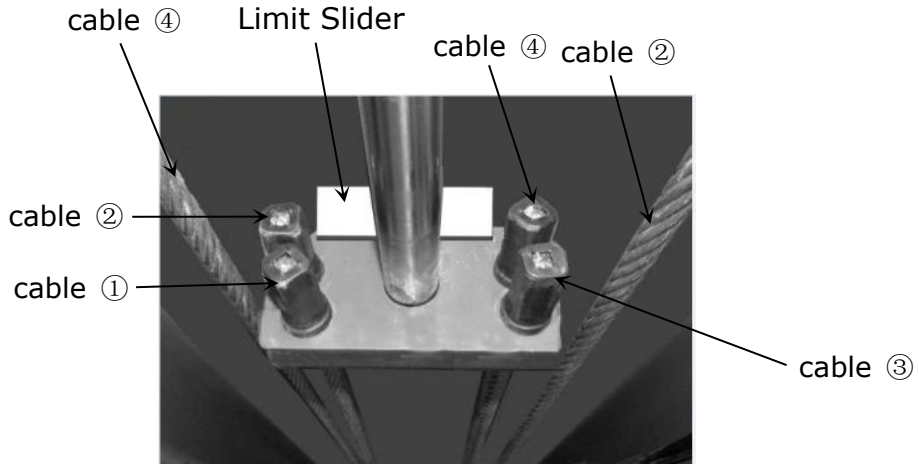

Illustration for Cable connection plate

Fig.29

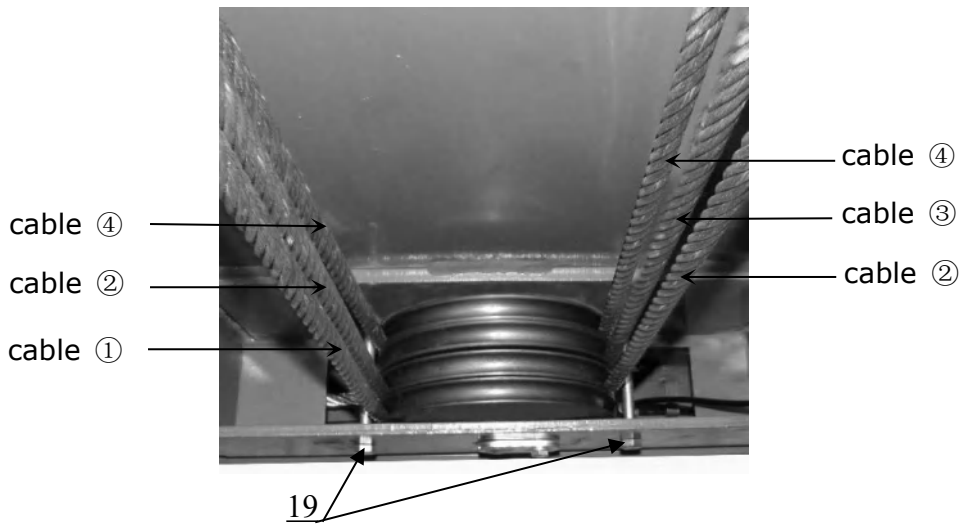

Fig.30

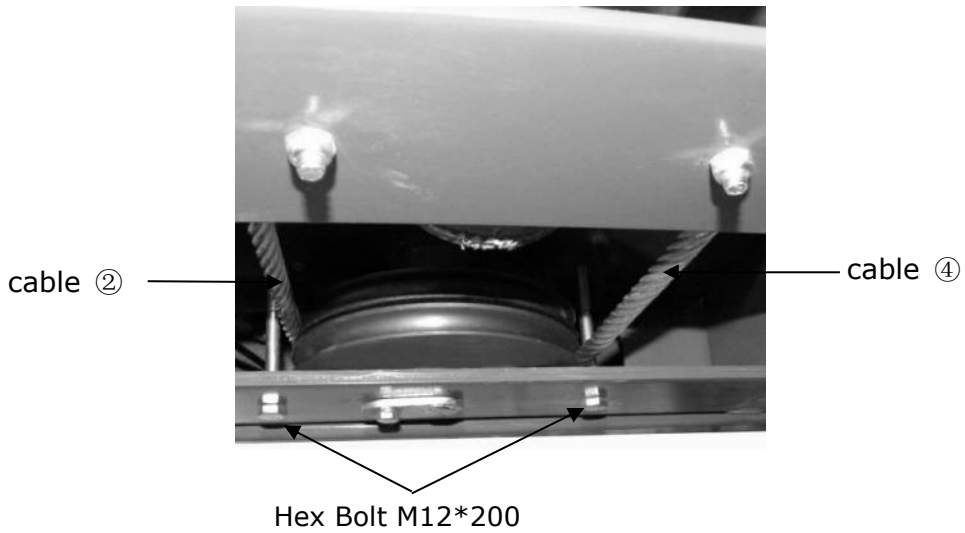
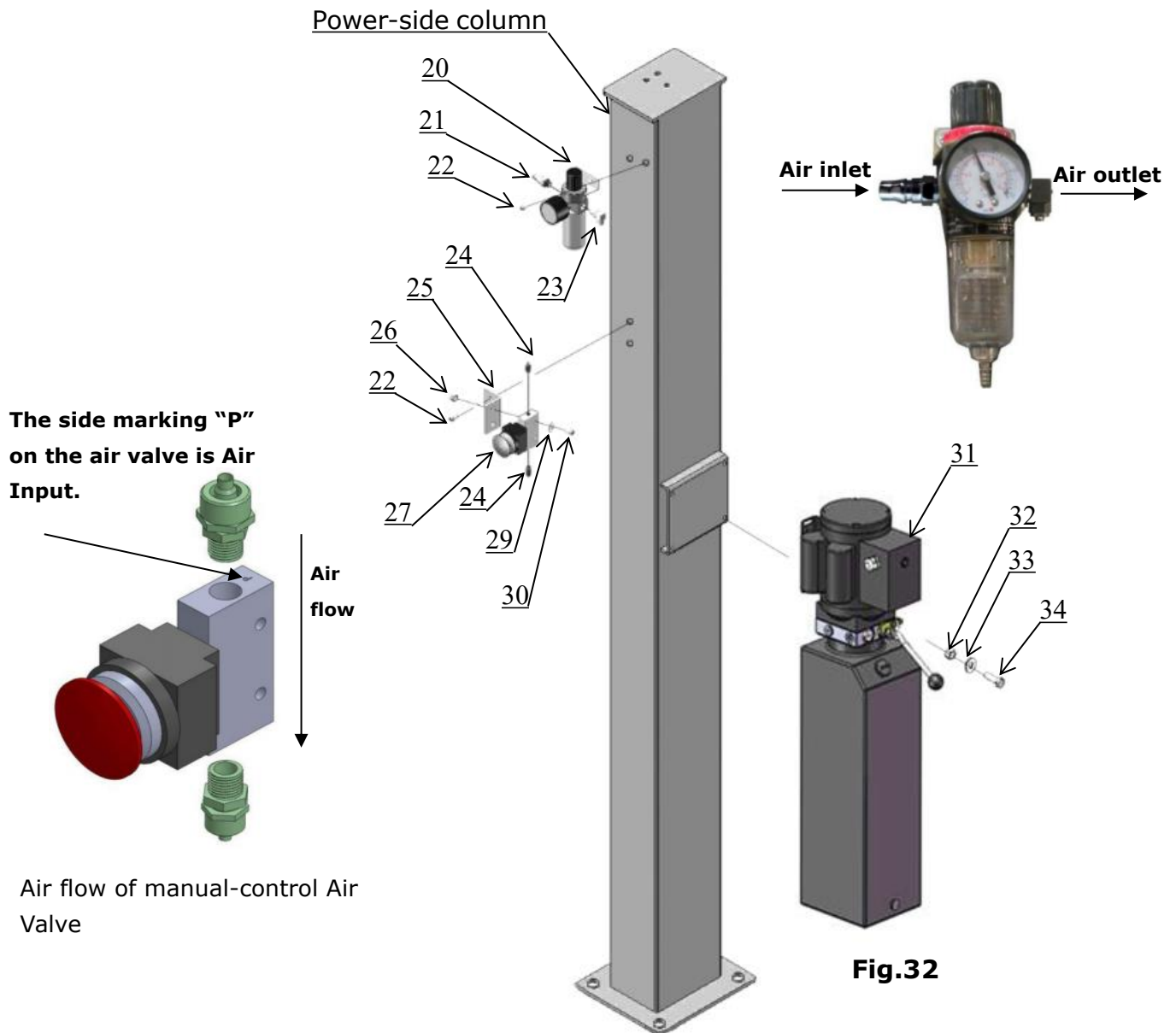

Fig.31

K. Install oil-water separator, manual control air valve and power unit

(See Fig. 32)



Item	Part No.	Description	QTY
20	10420145	Oil/water separator	1
21	1004334013	Straight fitting for air line	1
22	10209009	Round head bolt M6*8	12
23	10420076	90° fitting for air line 6*8 screw thread	1
24	10420159	Straight fitting for air line 6*8 crew thread	2
25	11420160	Fixing plate of Manual control valve	1
26	10420161	Self locking nut M4	2
27	10420162	Manual control air valve	1
29	10420148	Flat Washer φ4	4
30	10420164	Round head bolt M4*30	2
31		Manual hydraulic power unit	1
32	10209005	Self locking nut M8	4
33	10209004	Rubber ring	4
34	10209003	Hex bolt M8*25	4

L. Install hydraulic system (See Fig. 33, Fig.34, Fig.35)

Note: Oil hoses and oil return pipe connected to oil cylinder must be passed above the cable, cylinder inlet port must swing upward to avoid the oil hose and oil return pipe scratched by cable (see Fig.34)

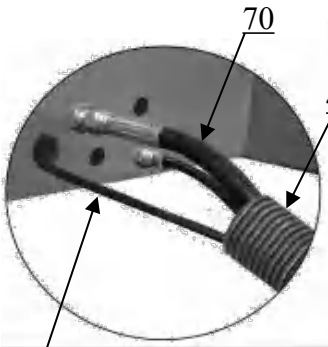
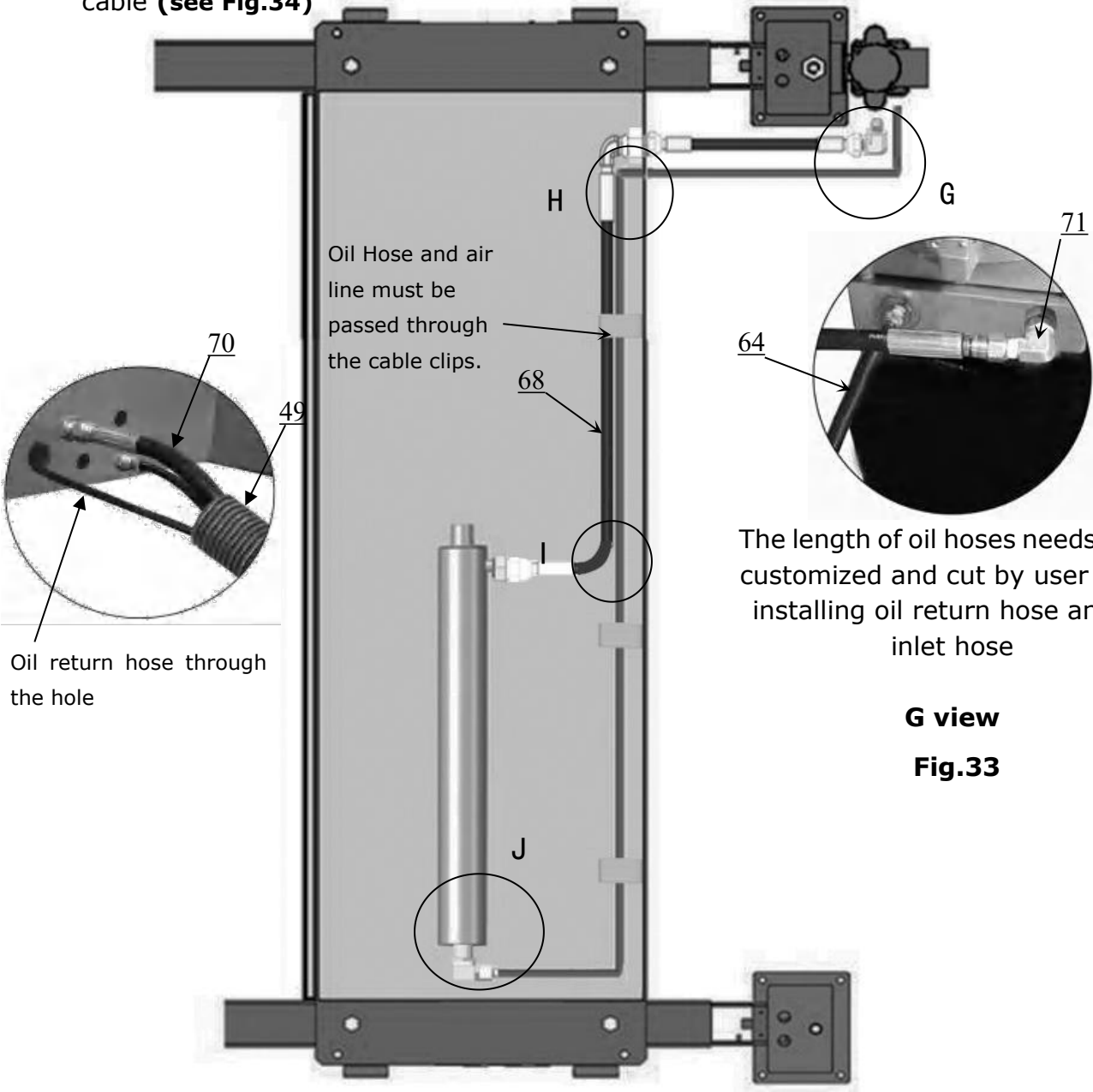

Oil return hose through the hole

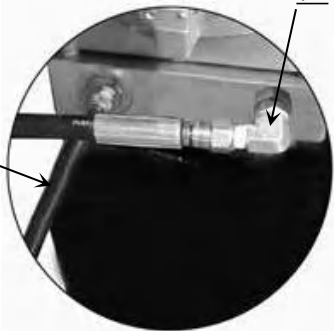

The length of oil hoses needs to be customized and cut by user when installing oil return hose and oil inlet hose

G view
Fig.33

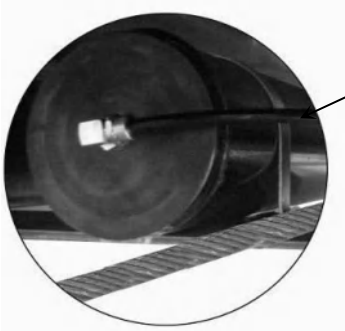

Assembly of oil return pipe
J View
Fig.35

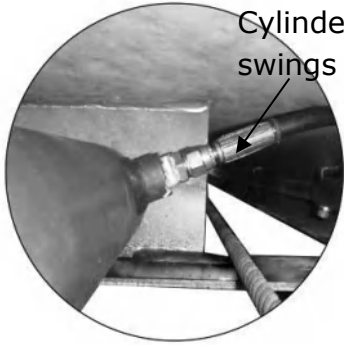

Cylinder inlet port swings upward
I View
Fig.34

M. Install air-line system

1. Cut off the $\phi 8 * \phi 6$ black air line of the front and rear cross beam at the position about 60mm from air cylinder, and then connect to the T fitting (No.65). (See Fig. 36).
2. Fix the T fitting (NO.65A) with nut (NO.69C) on the platform, and connect with the straight fitting (NO.65B). (See Fig. 37).
3. Connect two T fittings which installed in step 1 & step 2 with $\phi 8 * \phi 6$ black air line as shown. Connect the manual air valve to the straight-fitting (NO.65B).

Note: the actual length of air line can be cut by installer. (See Fig. 38, Fig. 39).

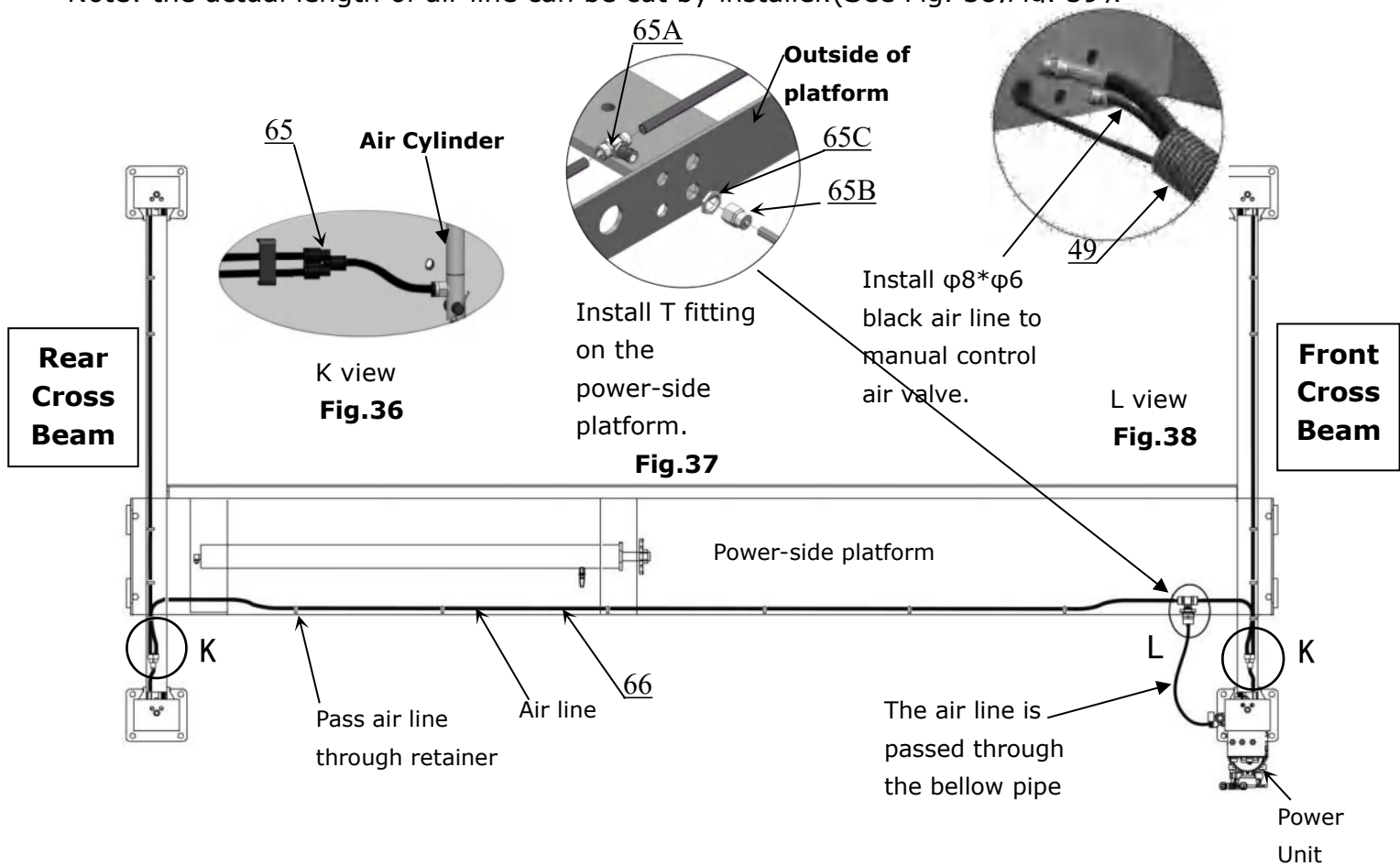

4. Connecting Oil-water separator and manual control air valve with $\phi 8 * \phi 6$ air line(No.67)
(See Fig.39)

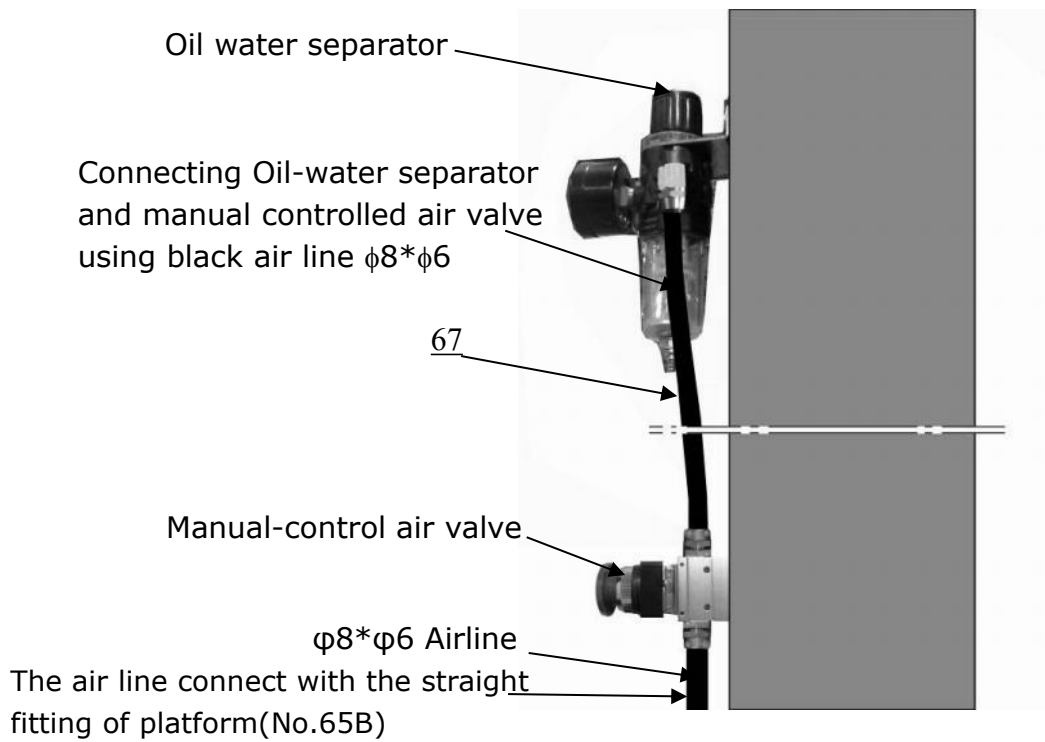

Fig.39

5. Connect to the air source , adjust the air pressure of oil-water separator to 0.8 MPa(See Fig.40)

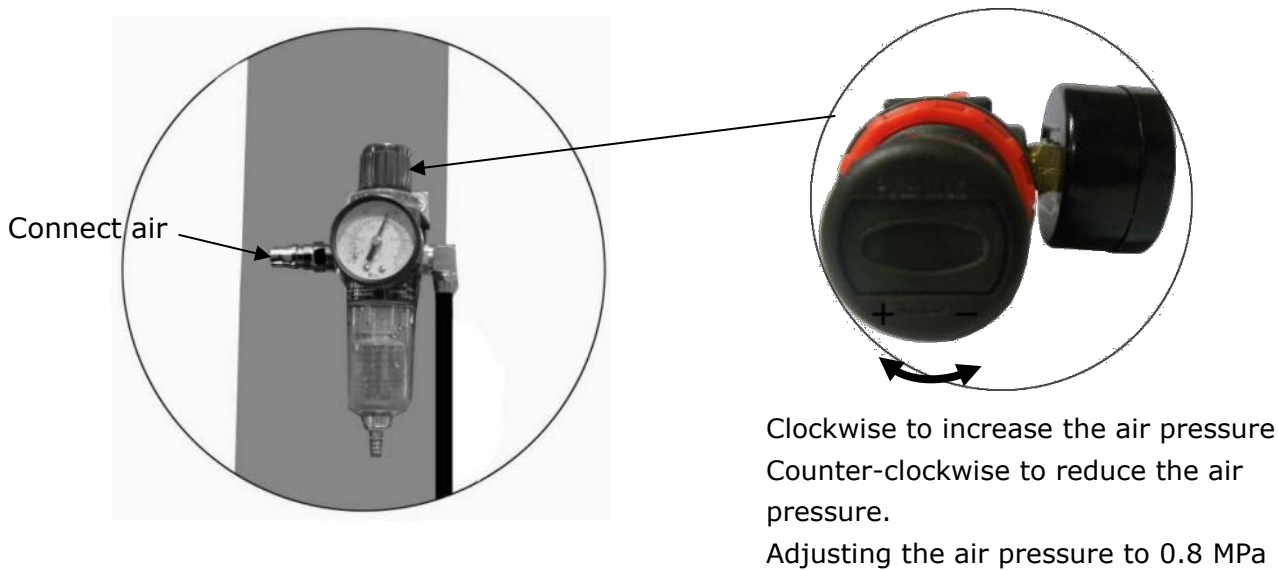

Fig.40

N. Install Electrical System

Connect the power source on the data plate of Motor.

Single phase motor (See Fig. 41)

Connecting the two power supply wires (active wire **L1** and wire **L3**) to terminals of AC contactor marked L1, L3 respectively. Earth wire(yellow and green wire) is connected with the earth wire terminal of the motor

Motor wiring diagram of single phase power unit

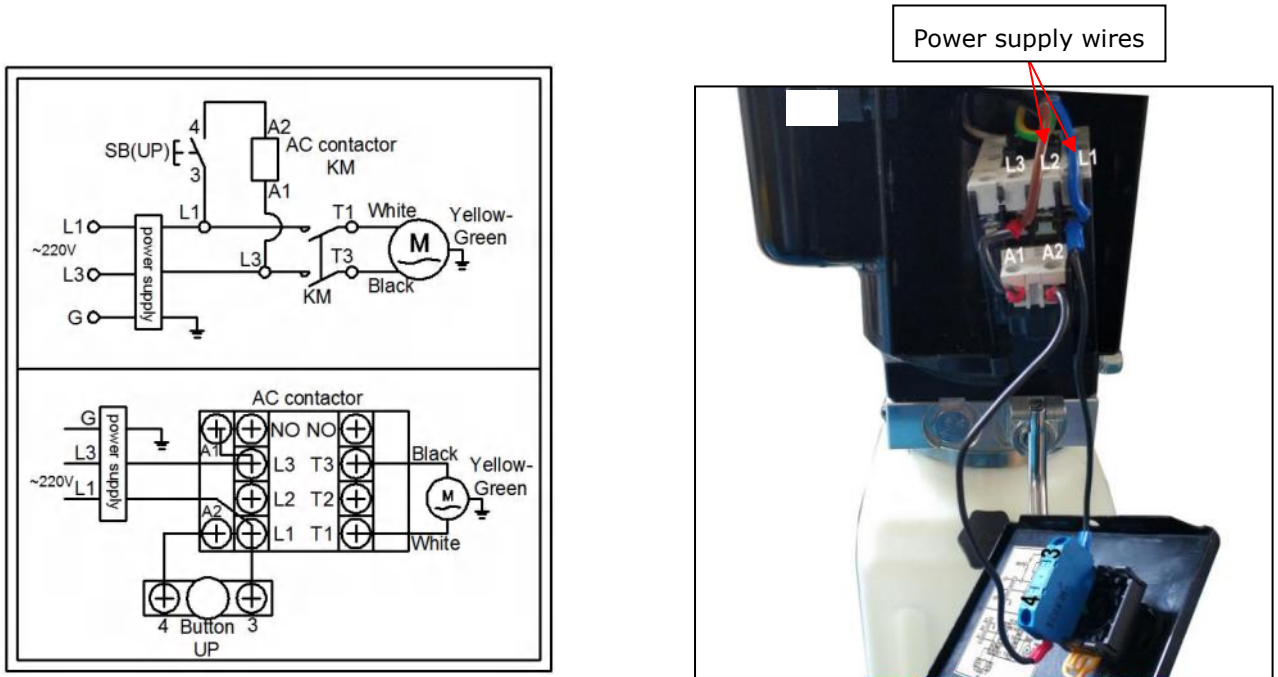

Fig. 41

⚠ DANGER All electrical wiring must be performed by a licensed and certified electrician. Before ensuring the main power has disconnected from the lift and cannot be re-applied until all procedures have been completed, don not perform any maintenance or installation to the lift.

⚠ DANGER Do not use the lift if the wires are damaged or severely worn. If the vehicle rises without noticing damage or extreme wear, carefully lower the vehicle to the ground. Once the lift is on the ground, remove it, disconnect the power, and arrange for protection.

O. Install spring and safety cover of cross beam (See Fig. 42)

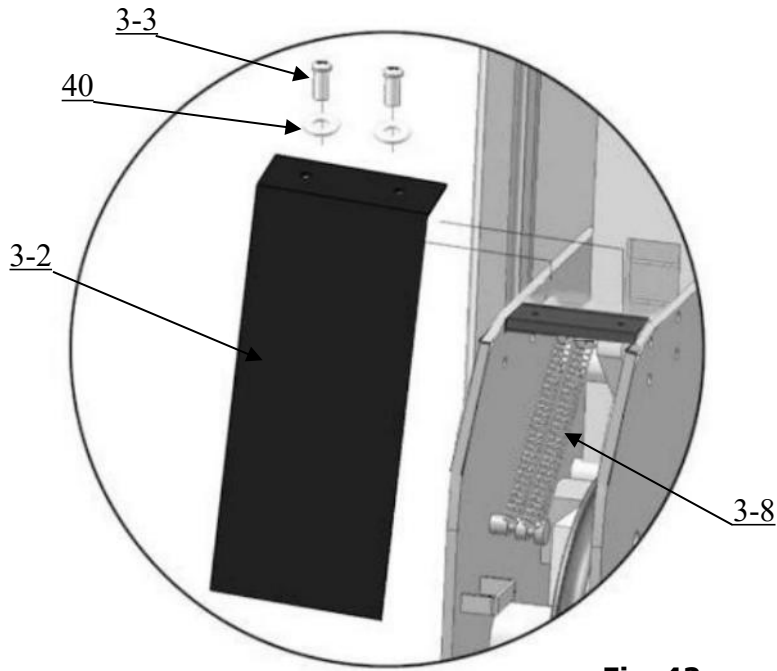

Fig. 42

P. Install Drive-in ramp, Tire stop plate. (See Fig. 43, Fig. 44)

Install Drive-in ramp

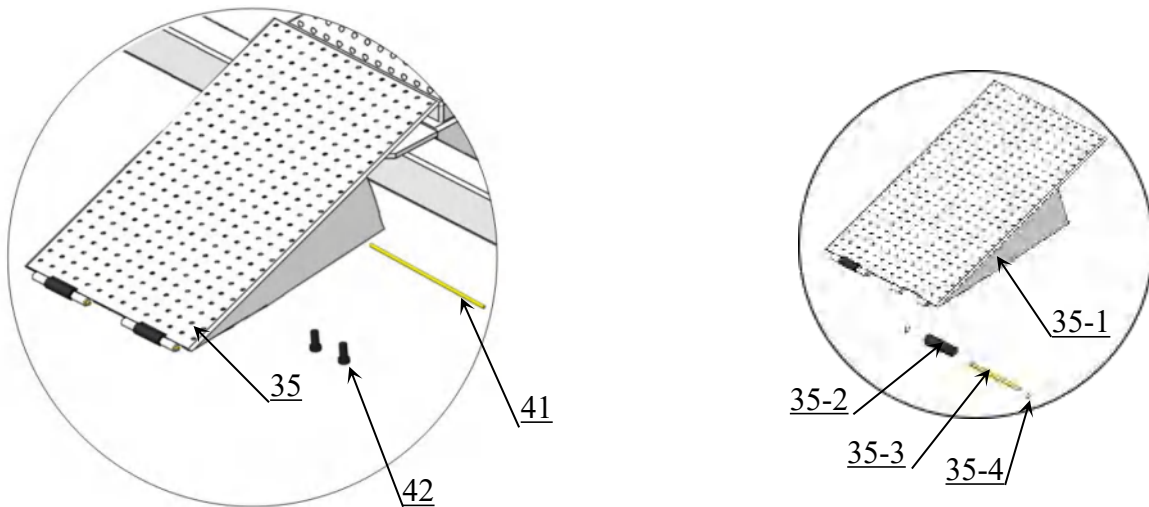

Fig.43

Install Tire stop plate

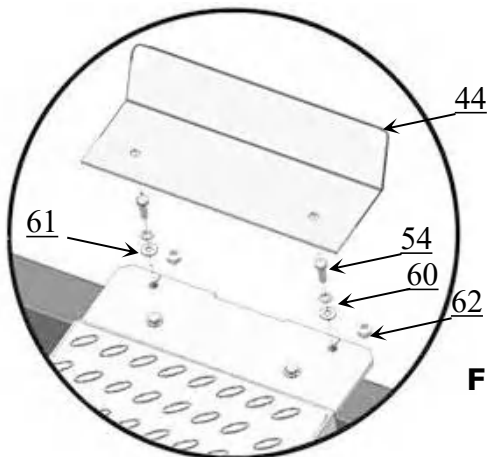

Fig. 44

Item	Part No.	Description	Qty
35-1	11400004	Drive-in ramp	2
35-2	11610667	Roller	4
35-3	11620043	Roller pin	4
35-4	10209010	φ10 clip ring	8

IV. EXPLODED VIEW

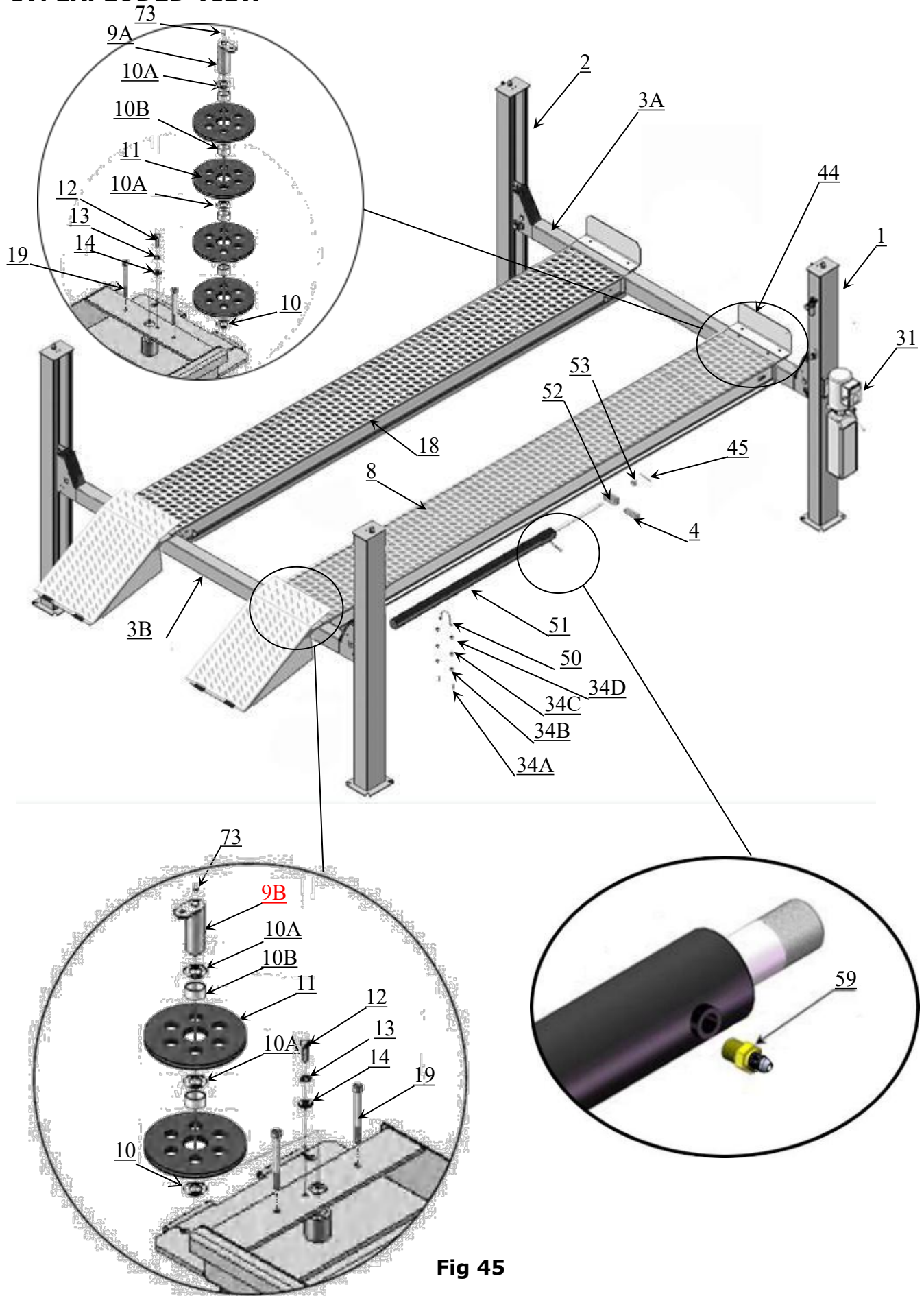

Fig 45

Parts list for PRO-40 PRO-40E

Item	Part NO.	Description	PRO-40	PRO-40E
1	1104331001A	Power side Column	1	1
2	1104331002A	Offside Column	3	3
3A	1104352002A-03	Cross Beam Assy.A	1	1
3B	1104352002B-03	Cross Beam Assy.B	1	1
4	10481023	Slider block	1	1
5	10201140	Anchor Bolt 3/4*6-1/2	16 sets	16 sets
6	11481036	Safety Ladder	4	4
7	10481018	Hex Nut M33*3.5	12	12
7A	40100013	Self lock nut M33*3.5	4	4
8	11400001-04	Power-side Platform	1	0
	11400029-04		0	1
9A	1104483001A	Pulley shaft	1	1
9B	1104483002A-01		1	1
10	10481069	Pulley washer	10	10
10A	10481021-01	Pulley washer	4	4
10B	1004484003	Bush	10	10
11	11481639-01	Pulley	6	6
12	1004514007	Hex bolt M12*25	2	2
13	10420026	Lock Washer φ12	2	2
14	10206006	Flat Washer φ12	2	2
15	10481078	Hex bolt M24*60	8	8
16	10481003	Lock Washer Φ24	8	8
17	10481002	Flat Washer Φ24	8	8
18	11400002-03	Offside platform	1	0
	11400030-03		0	1
19	10481017	Hex bolt M12*200	4	4
20	10420145	Oil-water separator	1	1
21	1004334013	Straight fitting for air line	1	1
22	10209009	Round head bolt M6*8	12	12
23	10420076	90° fitting for air line 6*8	1	1
24	10420159	Straight fitting for air line 6*8	2	2
25	11420160	Fixing plate of Manual control air valve	1	1
26	10420161	Self locking nut M4	2	2
27	10420162	Manual control air valve	1	1
28	11481617-01	Pulley	4	4
29	10420148	Flat Washer φ4	4	4
30	10420164	Round head bolt M4*30	2	2
31	071107	Manual hydraulic power unit	1	1
32	10209005	Self locking nut M8	6	6
33	10209004	Rubber ring	4	4
34	1061K050	Hex Bolt M8*30	6	6
34A	10209003	Hex Bolt M8*25	2	2
34B	10209033	Flat Washer Φ8	2	2

Item	Part NO.	Description	PRO-40	PRO-40E
34C	10209034	Lock Washer $\Phi 8$	2	2
34D	10217002	Hex nut M8	2	2
35	11400004	Drive-in ramp Assy.	2	2
39	10420156	Protecting ring	1	1
40	10420045	Flat Washer $\phi 6$	20	20
41	11481016	Pin for Drive-in ramp	2	2
42	10420005	Fixing bolt M5*8	4	4
43	10481500	Parts box	1	1
44	11481638	Tire stop plate	2	2
45	10481020	Cotter pin	1	1
46	10620065	Shim (2mm)	20	20
	10201090	Shim (1mm)	20	20
47	10217069	Hex bolt M12*30	4	4
48	11481046-01	Cable limit pin	4	4
49	1004354004	Platform lock plate L=56 1/2"	1	1
50	11400011	Fixed ring for cylinder	1	1
51	C804412	Cylinder	1	1
52	11400611	Cylinder connecting plate	1	1
53	1004356001	Hex nut M42*4.5	1	1
54	10481001	Hex screw M24	4	4
55	10400005-03	① Cable L=190 15/16"	1	0
	10400022-03	① Cable L=249 13/16"	0	1
56	10400008-03	② Cable L=576 3/4"	1	0
	10400025-03	② Cable L=694 7/16"	0	1
57	10400006-03	③ Cable L=272 13/16"	1	0
	10400023-03	③ Cable L=331 13/16"	0	1
58	10400007-03	④ Cable L=494 15/16"	1	0
	10400024-03	④ Cable L=612 11/16"	0	1
59	10420119	Fitting 1/4JIC(M)*3/8NPT(M)	1	1
60	10201114	Lock Washer $\phi 20$	1	1
61	10209128	Flat Washer $\phi 20$	1	1
62	10420175A	Hex screw M20	1	1
63	10420166	90° Fitting screw thread	1	1
64	1004354002-01	Oil Return pipe (black) L=277 3/4"	1	0
	10400028-01	Oil Return pipe (black) L=336 13/16"	0	1
65	85090120	Y fitting for air hose	3	3
65A	1004094003	T Fitting 6*8	1	1
65B	1061K110	Straight Fitting 6*8	1	1
65C	1004014008	Thin nut G1/4	1	1
66	10481065	Air hose L=456 11/16"(black)	1	0
	10400027	Air hose L=515 3/4" (black)	0	1
67	10420167A	Air hose L=18 1/8"(black)	1	1
68	10481083-03	Oil hose L=135 1/4"	1	0
	10400026-02	Oil hose L=193 7/8"	0	1

Item	Part NO.	Description	PRO-40	PRO-40E
69	10420120	Extended straight fitting with nut	1	1
70	10481011-01	Oil Hose L=56 1/2"	1	1
71	10209060	90° Fitting for power unit	1	1
72	1104354001	Backing plate	4	4
73	10620064	Grease Fitting	6	6

4.1 Cross beam exploded view

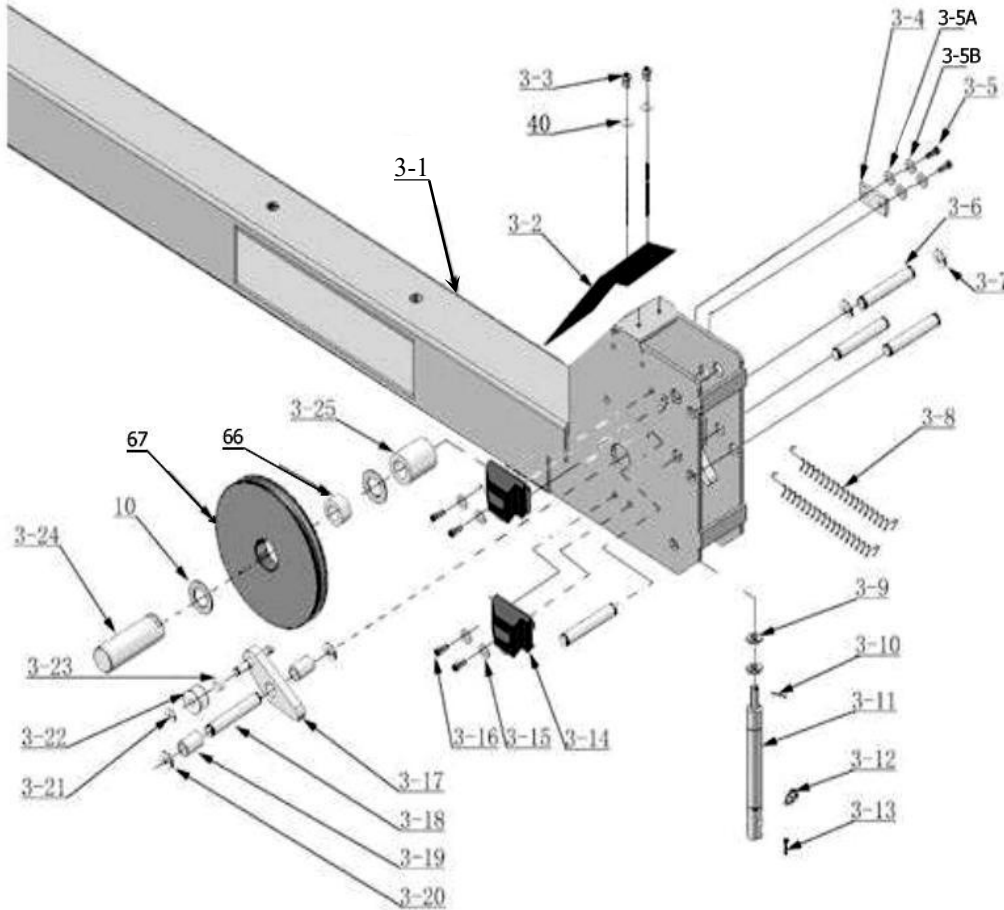

Fig 46

Item	Part No.	Description	QTY.
3-1	11400003A-03	Cross Beam Assy.A	1
	11400003B-03	Cross Beam Assy.B	1
3-2	11481618	Cross Beam Cover	4
3-3	10209009	Round Head Bolt M6*8	8
3-4	1104332001-01	Limit Plate	4
3-5	10101029	Socket Bolt M12*20	8
3-5A	10420026	Lock Washer φ12	8
3-5B	10206006	Flat Washer φ12	8
3-6	11481029	Pin	12
3-7	10420037	Clip Ring	24
3-8	10420033	Spring	8
3-9	10209021	Hex Nut M10	8
3-10	10420049	Cotter Pin	4
3-11	10400020	Air Cylinder	4

Item	Part No.	Description	QTY.
3-12	10481073	Fitting for Air Cylinder	4
3-13	10420046	Cotter Pin	4
3-14	10481070	Slider Block (HK020)	16
3-15	10209033	φ8 Flat Washer	40
3-16	10420043	Socket Bolt M8*20	32
3-17	11481642	Slack-cable safety lock (Left)	2
	11481643	Slack-cable safety lock (Right)	2
3-18	11481028	Pin	8
3-19	11481032	Pin Bush For Slack-cable Safety Lock	8
3-20	10610008	Clip Ring	16
3-21	10209010	Clip Ring	4
3-22	10481027	Tension Pulley	4
3-23	1104483003	Spacer	4
3-24	11481030-01	Pulley shaft	4
3-25	11481031	Pulley Bush	4

4.2 Cylinder C804412 (Old code 10400017) Exploded View

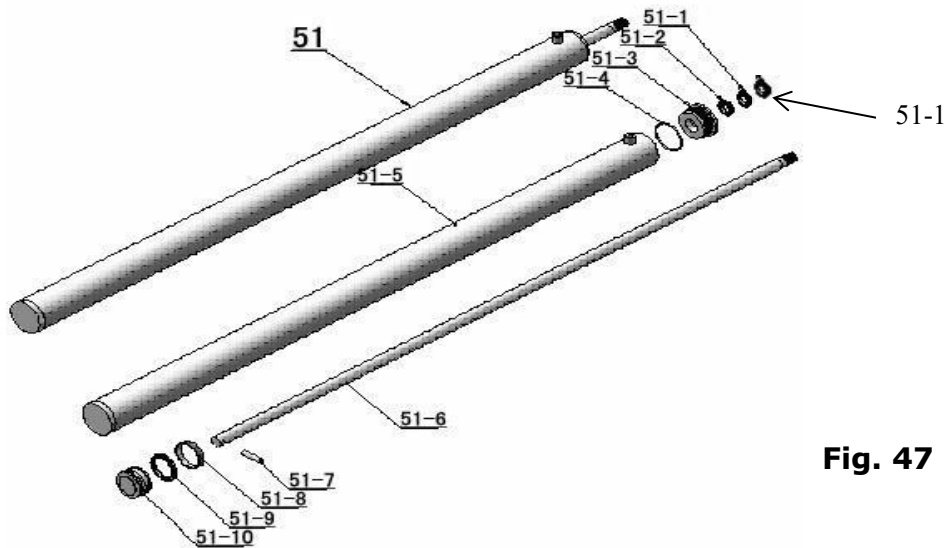

Fig. 47

Item	Part No.	Description	QTY.
51-1	10217078	Dust Ring	1
51-2	1004356003	Y- Ring IDI	1
51-3	11400035	Head Cap	1
51-4	1004356002	O- Ring	1
51-5	11400033	Bore Weldment	1
51-6	11400031	Piston Rod	1
51-7	10400015	Pin	1
51-8	10400014	Support Ring	1
51-9	10400012	Y- Ring OSI	1
51-10	11400036	Piston	1
51-11	1004356004	Support Ring	1

4.3 Part lift for 220V/60Hz Single Phase Manual Power Unit

Illustration of Hydraulic Valve for power unit (See Fig.48)

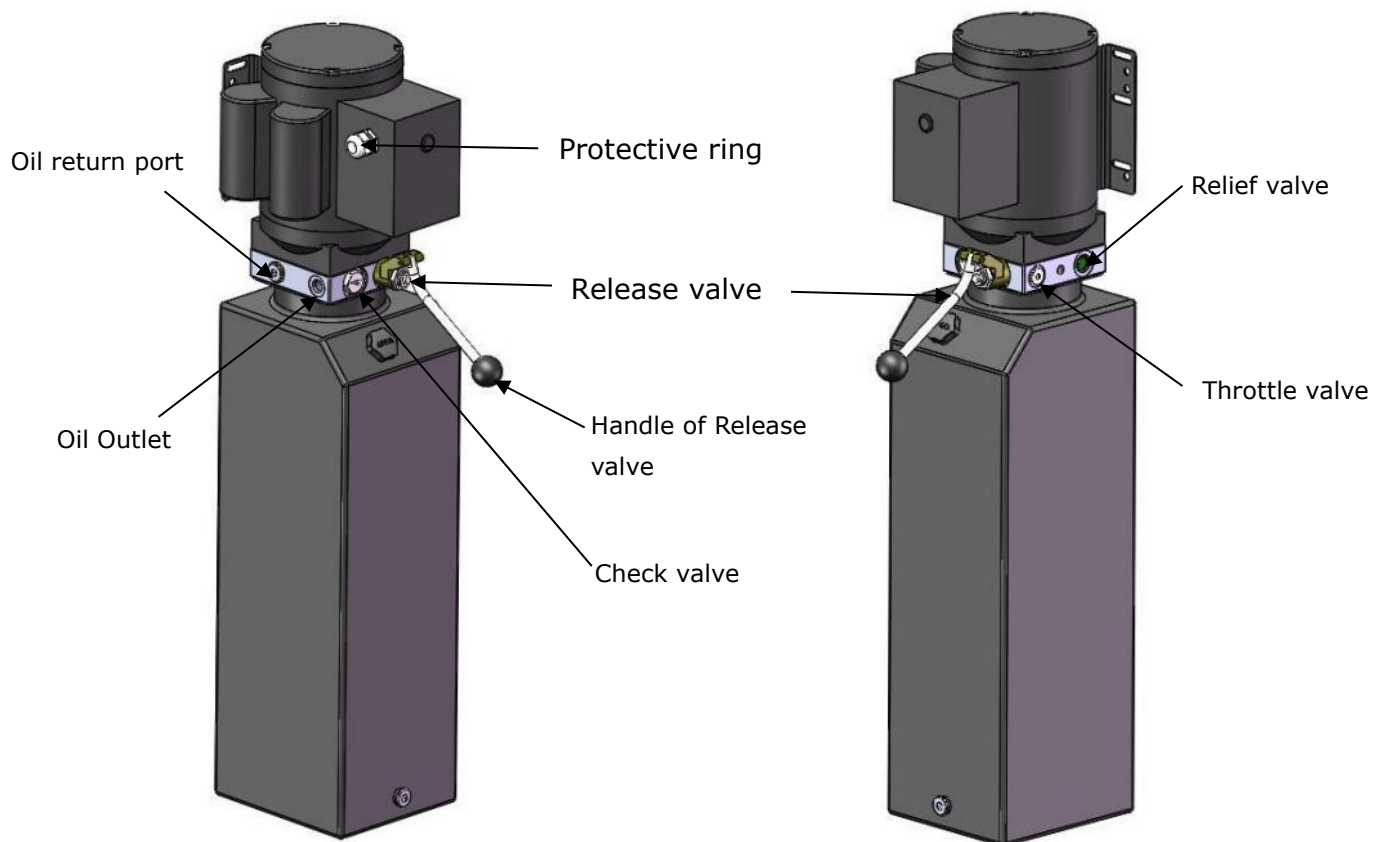

Fig.48

4.3.1 Adjust the lower speed

You can adjust the lower speed of the lift if needing: Turn the Throttle Valve in clockwise direction to decrease the lower speed, or increase the speed in counterclockwise direction.

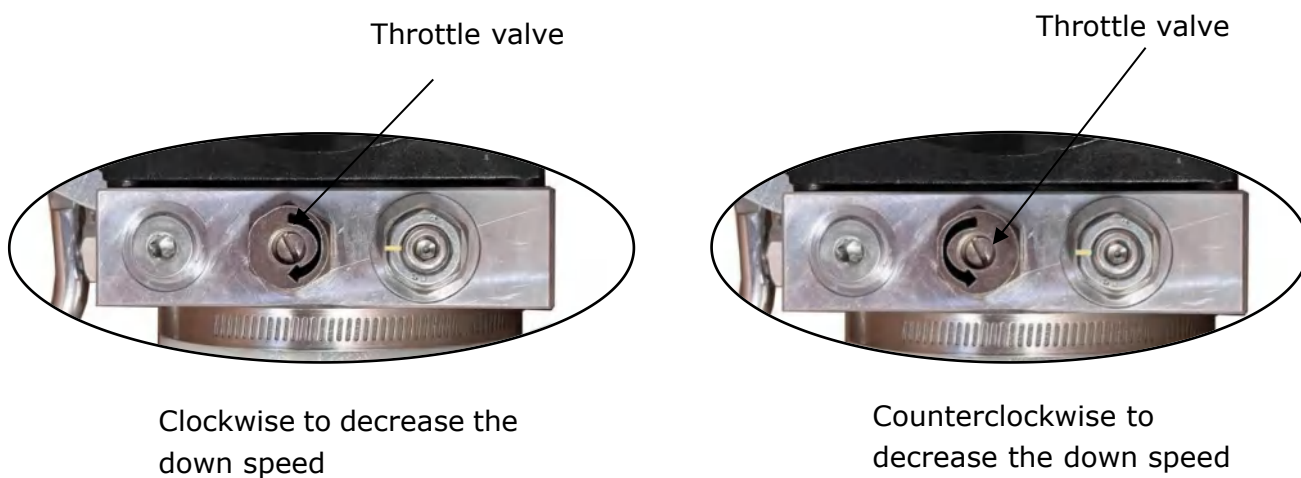

Fig.49

V. TEST RUN

1. Fill the reservoir with approximately 26L Hydraulic Oil (**Note:** In consideration of Power Unit's durability, please use **Hydraulic Oil 46#**).
2. Press the button on the power unit, the Cables will be strained. Check whether the Cables match the Pulley. Make sure the Cables are not across.
3. Press the release handle of the power unit to lock the Cross-beam to the safety ladders, and then adjust the platforms to be level by adjusting the nuts of Safety Ladders.
4. Adjust the cable fitting Hex nuts to make platforms and four safety locks work synchronously. Lift up and down for several times, meanwhile do the synchronous adjustment till the four Safety Devices can be locked and released at the same time.
5. Adjust the clearance between the post and the plastic slider of Cross-beam to about 2mm, and then tighten the fixing nut of slider.
6. After finishing the above adjustment, testing the lift with load. Lift the Platforms in low position first, make sure the Platforms can be up and down synchronously and the Safety Device can be locked and released synchronously. And then raise the lift to the top completely. If there are anything improper, repeat the above adjustment.

Circuit Diagram of Hydraulic System

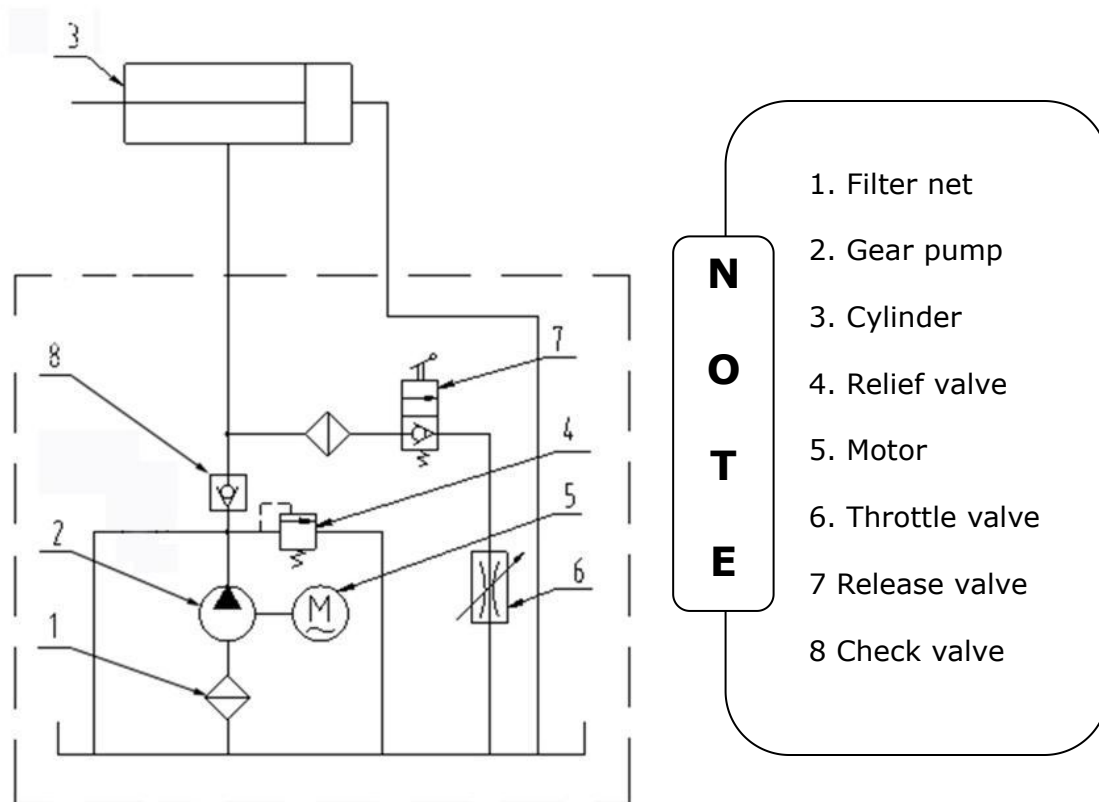

Fig.50

VI. OPERATION INSTRUCTIONS

To lift vehicle

1. Keep clean of environment near the lift;
2. Drive vehicle to the Platform and put on the brake;
3. Turn on the power and press the button, raise the lift to the working position;

Note: make sure the vehicle is steady when the lift is raised.

4. Press the Handle of release valve to lock the lift in the safety position. Make sure the Safety device is locked at the same height.

⚠️ WARNING It is unsafe to work under a lift without locked at the safety device after it has been lifted up, which may causes vehicle fall, damage, lift damage, human injury or even death.

To lower vehicle

1. Be sure the clearance of around and under the lift, only leaving operator in lift area;
2. Press the button, the lift will be raised for 3-5 seconds, and then press the button of Manual-controlled air valve by hand to make sure the safety device released, press the handle of release valve by the other hand then the lift starts being lowered automatically;
3. Drive away the vehicle when the lift is lowered to the lowest position.
4. Turn off the power.

VII. MAINTENANCE SCHEDULE

Monthly:

1. Re-torque the anchor bolts to 150 N·m;
2. Lubricate cable with lubricant;
3. Check all cable connection, bolts and pins to insure proper mounting;
4. Make a visual inspection of all hydraulic hoses/lines for possible wear or leakage;
5. Lubricate all Rollers, Safety devices with 90wt. gear oil or equivalent.

Note: All anchor bolts should take full torque. If any of the bolts does not function for any reason, DO NOT use the lift until the bolt has been replaced.

Every six months:

1. Make a visual inspection of all moving parts for possible wear, interference or damage.
2. Check and adjust as necessary, equalizer tension to insure level lifting.
3. Check the vertical of columns.

Oil cylinder maintenance:

In order to extend the service life of the oil cylinder, please operate according to the following requirements.

1. Recommend to use N46 anti-wear hydraulic oil.
2. The hydraulic oil of the lifts should be replaced regularly during using. Replace the hydraulic oil 3 months after the first installation, Replace the hydraulic oil once a year afterwards.
3. Make at least one full trip raising and lowering per day. For exhausting the air from the system, which could effectively avoid the corrosion of the cylinder and damage to the seals caused by presence of air or water in the system.
4. Protect the outer surface of the oil cylinder's piston rod from bumping and scratching, and timely clean up the debris on the oil cylinder dust-ring and the piston rod.

 **DANGER** Make sure the lift is completed disconnected from the power source before maintenance. If there is any external electrical lock/shutdown device, make sure to implement them before maintenance. The contact with high voltage/current, may cause injury or even death.

VIII. TROUBLE SHOOTING

TROUBLE	CAUSE	REMEDY
Motor does not run	<ol style="list-style-type: none"> 1. Start Button does not work 2. Wiring connections are not in good condition 3. Motor burned out 4. AC contactor burned out 5. Height limit switch is damaged 	<ol style="list-style-type: none"> 1. Press start button. 2. Repair all wiring connections 3. Repair or replace motor 4. Replace AC contactor 5. Replace
Motor runs but the lift is not raised	<ol style="list-style-type: none"> 1. Motor runs in reverse rotation 2. Release valve in damage 3. Gear pump in damage 4. Relief valve or check valve in damage 5. Low oil level 	<ol style="list-style-type: none"> 1. Reverse two power wire 2. Repair or replace 3. Repair or replace 4. Repair or replace 5. Fill tank
Lift does not stay up	<ol style="list-style-type: none"> 1. Release valve out of work 2. Relief valve or check valve leakage. 3. Cylinder or fittings leaks 	Repair or replace
Lift raises too slow	<ol style="list-style-type: none"> 1. Oil line is jammed 2. Motor running on low voltage 3. Oil mixed with Air 4. Pump leaks 5. Overload lifting 	<ol style="list-style-type: none"> 1. Clean the oil line 2. Check electrical system 3. Fill tank 4. Replace Pump 5. Check load
Lift cannot lower	<ol style="list-style-type: none"> 1. Safety device are in activated 2. Release valve damaged 3. Air Cylinder damaged 4. Air line leaks 	<ol style="list-style-type: none"> 1. Release the safeties 2. Replace or repair 3. Replace the cylinder 4. Check the air line

⚠️ WARNING A lift would be dangerous if operated by inexperienced or distracted operators. Operators should be fully aware that lifting a vehicle is a potentially life-threatening operation, especially if ignoring the mandatory safety precautions.

IX. CAR LIFT SAFETY TIPS

Put this safety tips in a place where you can always alert the operator. Please reference to the lift manufacturer's manual for specific information about the lift.

1. Check the lift daily. If the machine breaks down or has damaged parts, do not operate, and use original equipment parts to repair.
2. **Do not** overload . The rated weight of the manufacturer design is indicated on the label of the lift.
3. Position control of the vehicle and operation of the lift can only be done by a trained and authorized person.
4. **Do not** lift a car with occupants inside. Keep the customers or bystanders away from the lift.
5. Keep the area around the lift free of obstacles, lubricating oil, grease, garbage and other debris for a long time.
6. Carefully drive the vehicle onto the lift and lifting up to the required height for operation. **Noted:** lift it high enough if you are working underneath, and make sure the safety devices are locked.
7. **Noted:** removing(install) parts from(to) a vehicle would cause a sudden shift of gravity which may result in instability of the vehicle. Please refer to the vehicle manufacturer's service manual as a recommended procedure if you need remove/install parts from(to) the vehicle
8. Before lowering the lift , make sure all obstacles underneath, include tool tray, tool rack etc., are all removed.

X. LIFT DISPOSAL

When the car lift cannot meet the requirements for normal use and needs to be disposed, it should follow local laws and regulations.



Address:

SC Division: 1931 Joe Rogers Jr Blvd, Manning, SC 29102, USA

TX Division: 4310 Adler Dr., Suite #200, Dallas, TX 75211, USA

<http://www.amgohyd.com>

Manual No.: 72240204
Revision Date: 2026/02