

## SPECIFICATIONS

Model		PRO-18	PRO-18A
Lifting Capacity		18,000lbs	18,000lbs
Lifting Time		81S	81S
Overall Length(Inc Ramps)	A	294 1/4"	293 1/4"
Overall Length(No Inc. Ramps)	B	246 1/16"	236 1/4"
Overall Width	C	137 1/16"	137 1/16"
Width Between Posts	D	122 3/8"	122 3/8"
Max. Lifting Height	E	75 9/16"	77 9/16"
Max. Lock Height to top of runway		72 7/16"	74 7/16"
Overall Height	F	86 3/16"	86 13/16"
Minimum Height	G	7 7/8"	9 13/16"
Max. Underneath runway	H	68 7/8"	68 7/8"
Max. Lock Underneath runway		65 3/4"	65 3/4"
Drive-Thru Clearance	I	108 1/4"	108 1/4"
Width Between Runways	J	46"	46"
Outside Edge of Runways	K	89 15/16"	89 15/16"
Min. Four Wheel Align	L	/	99 13/16"
Max. Four Wheel Align	M	/	190 3/4"
Max. Two Wheel Align	N	/	191 3/4"
Gross Weight		3,474lbs	4,367lbs
Motor		2.0HP,220V/60Hz,single phase	

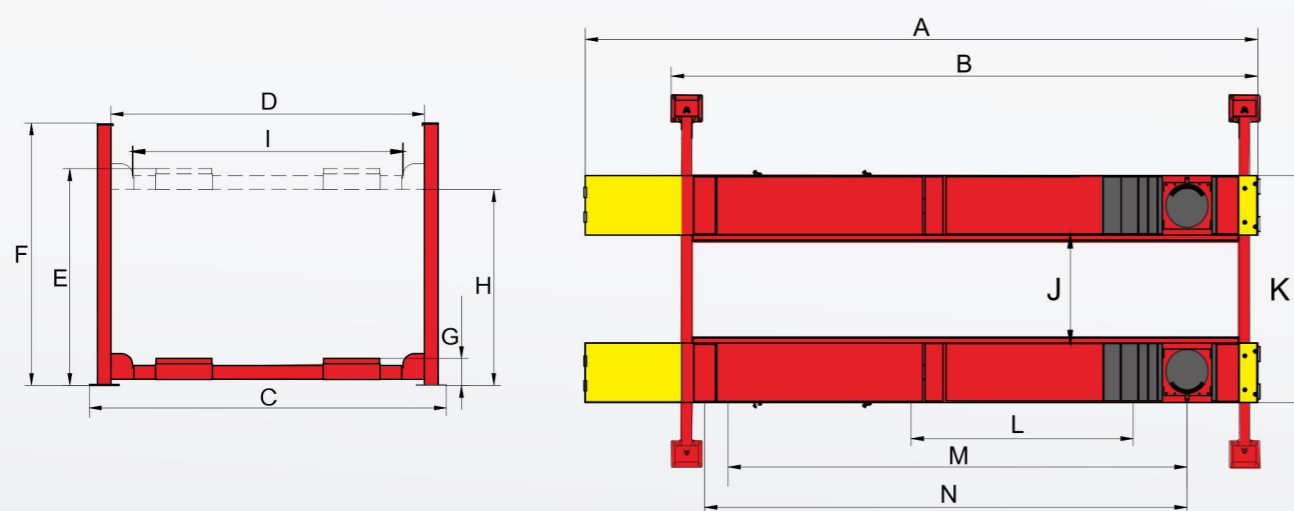

**AMGO**  **Hydraulics**  
The Manufacturing Powerhouse

## FOUR POST TRUCK LIFT

*AMGO's truck lift models are built with latest manufacturing technology and featured extra wide runways to accommodate a wide variety of vehicle types, from SUVs, Vans, mid-size trucks up to heavy-duty application with a 18,000lbs lifting capacity. Increased safety, durability and productivity have set up these models more superior in the competitive lift market.*



**Optional Rolling Jack**  
RJ-10A: pneumatic hydraulic type 10,000lbs

### AMGO HYDRAULIC CORPORATION

SC Division: 1931 Joe Rogers Jr Blvd, Manning, SC 29102, USA  
Tel:(803)505-6410

TX Division: 4310 Adler, Suite #200, Dallas, TX 75211, USA  
Tel:(214)377-8091

**AMGO**  **Hydraulics**  
We're More Than a Manufacturer. We Are the  
Leader in Innovation, Technology and Service  
[www.amgohyd.com](http://www.amgohyd.com)

**PRO-18**  
**PRO-18A**

**PRO-18**

18,000lbs

General service

**PRO-18A**

18,000lbs

Alignment service

- ✓ 18,000 lbs capacity;
- ✓ AMGO ETL certified power unit comes standard;
- ✓ Mechanical self-locking safety device with air-driven lock release;
- ✓ Primary multiple safety locks and cable-slack protection system come standard;
- ✓ Cable-driven, utilizing aircraft standard high quality cables;
- ✓ Hydraulic cylinder is designed and made to high standard, utilizing high quality oil seals and compensation valve;
- ✓ Non-skid diamond platforms;
- ✓ Integrated slip plates and adjustable turnplate pockets; for PRO-18A .
- ✓ Optional Rolling Jacks:
  - RJ-10A 10,000lbs capacity with pneumatic pump.



Double-safety locks

**FEATURES**

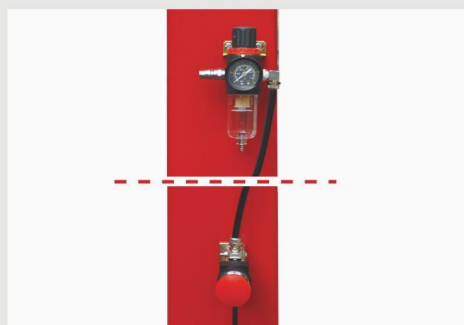

• Oil-water separator and solenoid air valve are installed on the power side column.

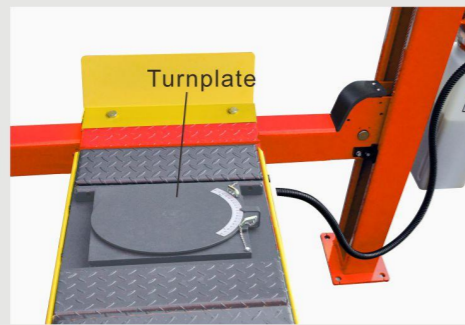

• Adjustable turnplates blocks for the PRO-18A, Optional turnplate. Kits No.: 40101

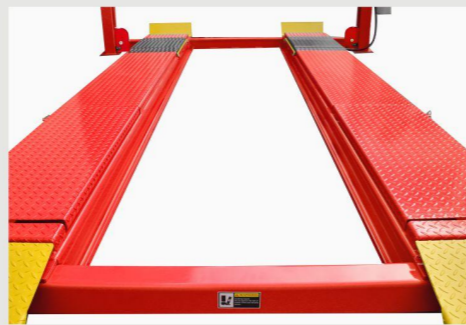

• Non-slip diamond platforms come as standard.



• Optional Air line kits. Kits No.:40102A



• Optional extension platform kit. Kits No.:41801-01



• Optional adjustable blocks used with extension platform , Kits No. 41803