

Installation And Service Manual

FOUR POST LIFT

Model:PRO-14, PRO-14A, PRO-14E,PRO-14AE

Cargo Claims

If there is any missing or damaged product during transportation, the buyer must notate on the shipping paperwork or refuse the shipment. NOTATE ALL DAMAGE OR REFUSE DAMAGED SHIPMENT!




DANGER

Read the entire contents of this manual before using this product. Failure to follow instructions and safety precautions could result in serious injury or even death. Make sure all other operators also read this manual. Keep this manual near the machine so that it can be seen by all users. By proceeding with installation and operation, you agree that you are fully understand the contents of this manual and take full responsibility for the use of the product.

CONTENTS

Profile	1
Important Safety Instructions.....	3
I.Product Features And Specifications	5
II.Installation Requirement	6
III.Installation Steps.....	8
IV.Exploded View	28
V.Test Run	36
VI.Operation Instructions.....	37
VII.Maintenance Schedule	37
VIII.Trouble Shooting	39
IX.Car Lift Safety Tips.....	40
X.Lift Disposal.....	40

Explanation of the safety warning symbols used in this manual

-  DANGER Risk of death or injury
-  WARNING Dangerous or unsafe practices that may result in death or injury
-  CAUTION Dangerous or unsafe practices that may result in personal injury, product damage or property damage
- ATTENTION Conditions that may result in damage to products or property

PROFILE

The four post lift is a commonly used vehicle repair and maintenance tool that uses a hydraulic or electric system that can lift the car up to a certain height so that the vehicle can be placed in a suitable position for inspection and repair. Car lifts can be divided into pneumatic and electric, which have the characteristics of safe and reliable, simple structure and quick installation.

This instruction manual is specially prepared for you. Your new lift is the product of over a decade of continuous research, testing and development and is the most technologically advanced lift on the market today.

Please make sure to read through this manual before operating the lift.

Record the information on the nameplate label here:

Model No.: _____

Serial No.: _____

Manufacturer date: _____

WARRANTY

The warranty period for the steel structure part of new car lift is 5 years; hydraulic components, bronze bushings, slider blocks and plastic parts are warranty for 3 years; electrical components and cables are warranty for 2 years. Rubber pads are without warranty. During the warranty period, the manufacturer will repair or replace the defective parts free of charge including shipping costs.

This warranty does not cover damage caused by normal wear and tear, improper use, damage in transit, or damage caused by lack of maintenance.

This warranty is unique and supersedes what is expressed and implied in all other warranties.

The manufacturer shall not be liable for any particular, indirect or accidental damage resulting in breach of or delay in the execution of the warranty. The manufacturer reserves the right to design and improve the product and has no obligation to make notice of the changes in advance.

The product warranty based on the above clause is based on the model number and serial number of the equipment. This information must be provided in conjunction with all warranty information at the time of service and warranty.

SAFETY WARNING LABEL

⚠ WARNING ⚠



Please read the user manual before operation.



Never allow unauthorized personnel near the equipment



Always wear protective shoes and mind your feet during lowering



Please mind your hands during operation.



Keep away from the equipment during operation



Use wheel chock to avoid vehicle moving.



Please lock the safety device before repairing the vehicle.



Please run away quickly from any falling objects.

PLEASE READ THE PRECAUTIONS CAREFULLY


No.71030135

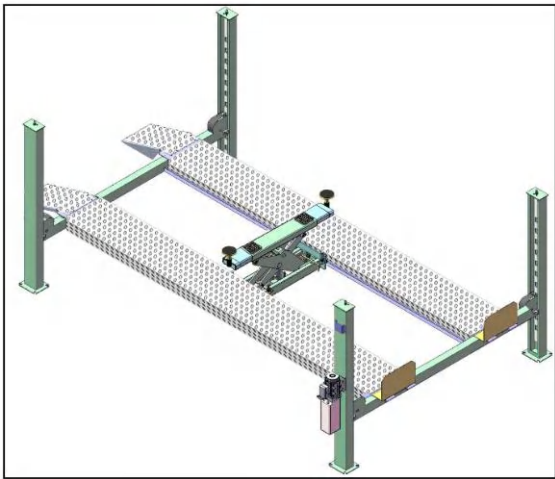
IMPORTANT SAFETY INSTRUCTIONS

In order to properly maintain your product and ensure operator safety, it is the responsibility of the product owner to read and follow these instructions!

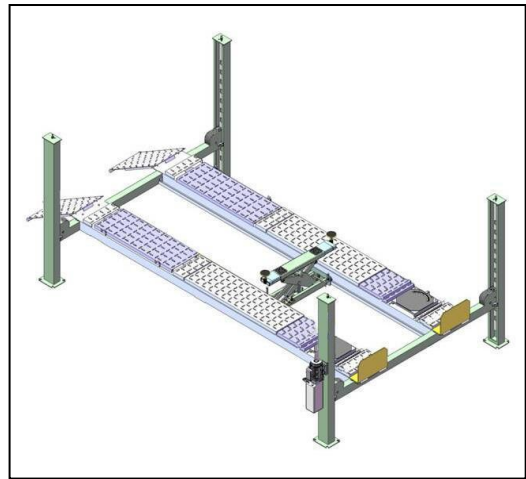
1. Ensure product installation full complies with all applicable local and national rules, ordinances and regulations;
2. Ensure that all operators are properly trained, know how to operate the unit safely, and are properly supervised;
3. Do not operate the lift until you are sure all parts are in place and operating correctly;
4. Keep your hands and feet away from the machine. Keep hands and feet away from any moving parts. Keep your feet away from the lift as it descends and avoid pressing on pointed objects;
5. Keep the work area clean. A cluttered workspace can lead to injuries;
6. The machine is only approved for indoor installation and use. Outdoor installation is prohibited;
7. Only trained operators are allowed to handle the lift machine. All untrained persons must stay away from the workplace. Never allow untrained persons to handle or operate the machine;
8. Use the lift properly. Use the lift in the correct way;
9. Warning! Keep persons and objects from the lift when lifting the a vehicle;
10. If the vehicle is at risk of falling, make sure no one is around the lift;
11. Before preparing to approach or service the vehicle, ensure that the safety device is in effect;
12. Dress appropriately when operating machines, and consider wearing non-slip steel-toe shoes for safety;
13. Beware of electric shock. In order to protect the operator from electric shock, the lift in use must be grounded. Do not connect the green wire to the terminal. This is the ground wire;
14. Danger! The power supply used in this type of lift has high voltage. Please disconnect the power supply before any circuit repair. Unplug in case the power supply is accidentally switched on during maintenance;
15. Warning! There is a risk of explosion. There are parts in the equipment that produce arc light and spark. Do not operate near flammable gas. This machine should not be placed in the lounge or basement;
16. Maintain with care. Keep the machine clean for better and safer operation. Perform proper lubrication and maintenance procedures according to the manual. Keep handles or buttons clean, dry, and free of oil;
17. Stay alert. Use common sense to observe what you are doing and stay alert;

18. Check for damaged parts. Check for adjustments to moving parts, damage to parts, or anything that may affect their operation. Do not use the machine if the parts are damaged;
19. Do not remove relevant safety parts from the machine. Do not use a lift if it is damaged or missing;
20. Operate the lift only at temperature between 5°C to 40°C (41°F to 104°F).

 **DANGER** Be very careful when installing, operating, maintaining or repairing this equipment. Failure to comply may result in property damage, product damage, injury or (in very rare cases) death. Ensure that only authorized personnel operate the equipment. All repairs must be carried out by an authorized technician. Do not modify the machine, this voids the warranty and increases the probability of personal injury or property damage. Ensure to read and follow this instructions on the label.



PRO-14/PRO-14E
Fig.1



PRO-14A/PRO-14AE
Fig.2

I. PRODUCT FEATURES AND SPECIFICATIONS

FEATURES

- Manual control system.
- Mechanical self-lock and air-drive safety release.
- Electric hydraulic power system, cable-drive.
- Strengthen and non-skid diamond platforms.
- Multiple turnplate pockets fit with different wheel base (only for PRO-14A,PRO-14AE).
- Adjustable platform and adjustable safety lock ladders.
- Optional Jack: With pneumatic pump.
- Optional turnplate: only for PRO-14A, PRO-14AE.

MODEL SPECIFICATIONS

Model	Lifting capacity	Lifting time	Overall length (incl. ramps)	Overall width	With between Columns	Max. Lifting height	Max. Locking height
PRO-14	14,000lbs	81S	258 9/16"	130 7/8"	116"	75 9/16"	72 7/16"
PRO-414E	14,000lbs	81S	287 1/16"	130 7/8"	116"	75 9/16"	72 7/16"
PRO-14A	14,000lbs	81S	257 1/2"	130 7/8"	116"	77 9/16"	74 7/16"
PRO-14AE	14,000lbs	81S	286"	130 7/8"	116"	77 9/16"	74 7/16"

Model	Overall height	Min. height	Max. Underneath height	Max Locking underneath height	Drive-thru dimension	Width between runways	Outside edge of runways	Motor
PRO-14	86 3/16"	7 7/8"	68 7/8"	65 3/4"	102 1/16"	46"	86"	2.0HP
PRO-414E	86 3/16"	7 7/8"	68 7/8"	65 3/4"	102 1/16"	46"	86"	2.0HP
PRO-14A	86 3/16"	9 13/16"	68 7/8"	65 3/4"	102 1/16"	46"	86"	2.0HP
PRO-14AE	86 3/16"	9 13/16"	68 7/8"	65 3/4"	102 1/16"	46"	86"	2.0HP

⚠ CAUTION When driving the vehicle into the lift, make sure it is positioned in middle of either group of runways. Any hit of the lift could result in damage to either the vehicle or lift.

II. INSTALLATION REQUIREMENT

A. TOOLS REQUIRED

↳ Rotary Hammer Drill ($\Phi 3/4''$)



↳ Hammer



↳ Level Bar



↳ English Spanner (12")



↳ Wrench Set

(10#, 12#, 13#, 14#, 17#, 19#, 24#, 30#)



↳ Ratchet Spanner With Socket
(28")



↳ Carpenter's Chalk



↳ Screw Sets



↳ Tape Measure (295")



↳ Pliers



↳ Lock Wrench



↳ Socket Head Wrench
(3#, 5#, 6#)



Fig. 3

B. Equipment storage and installation requirements.
The equipment should be stored or installed in a shady, normal temperature, ventilated and dry place.

C. SPECIFICATIONS OF CONCRETE (See Fig. 4)

Specifications of concrete must be adhered to the specification as following.
Failure to do so may result in lift and/or vehicle falling.

1. Concrete must be thickness 4" minimum and without reinforcing steel bars, and must be dried completely before the installation.
2. Concrete must be in good condition and must be of test strength 3,000psi minimum.
3. Floors must be level and no cracks.

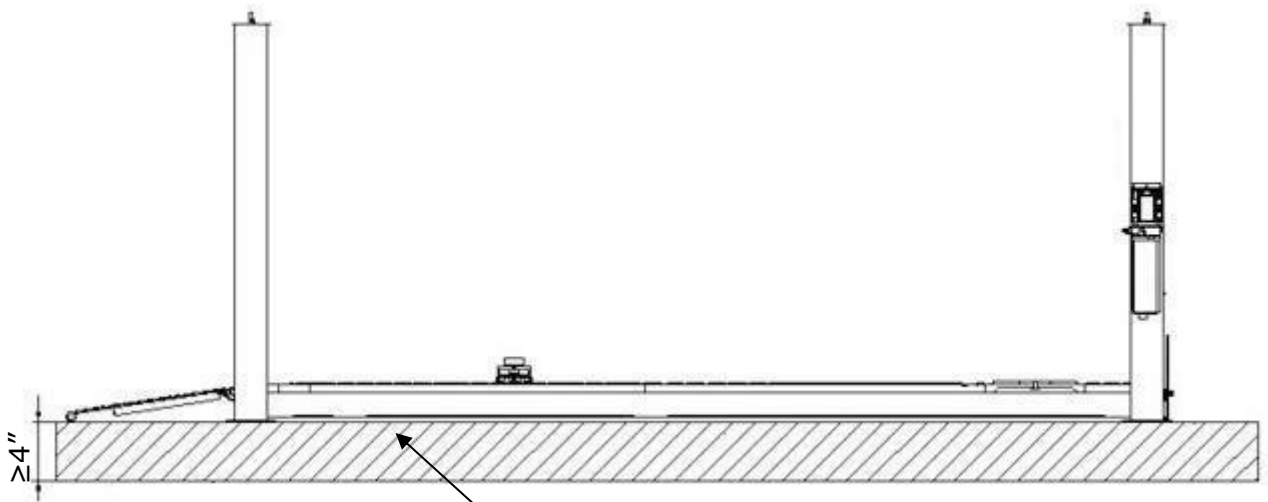


Fig. 4

Concrete intensity must be 3000PSI minimum

D. AIR SUPPLY

Air pressure requirement: 0.8Mpa, Air line size $\Phi 8 * \Phi 6$ and $\Phi 6 * \Phi 4$.

E. POWER SUPPLY

You are required to use a licensed and qualified electrician for the installation process. The power supply capacity must be more than 3.0HP, with a cord larger than 12AWG, and must be properly grounded.

⚠ DANGER All electrical wiring must be performed by a licensed and certified electrician. Attempting to connect the circuit without proper certification may result in damage to the lift or electrocution, resulting in serious injury or death.

III. STEPS OF INSTALLATION

A. Location of Installation

Check and insure the installation location (concrete, layout, space size etc.) is suitable for lift installation.

B. Check the Parts Before Assembly

1, The equipment should be unload and transfer by forklift. **(See Fig.5)**

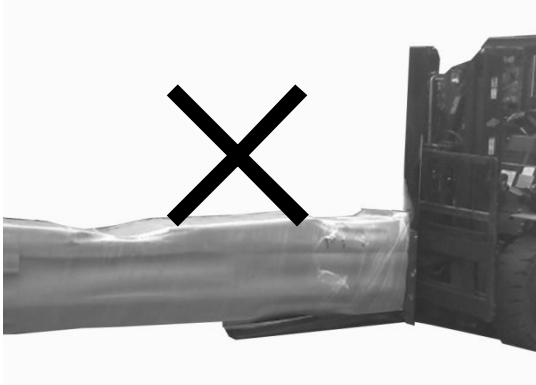
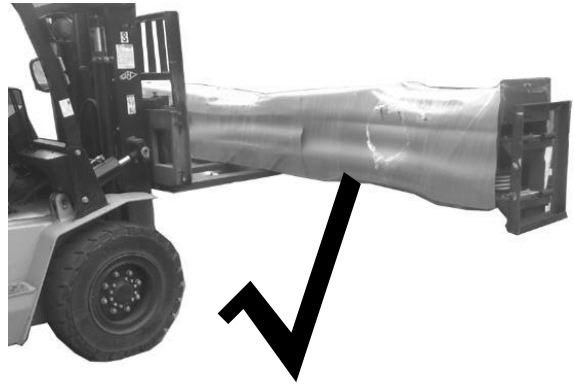


Fig. 5



2. Packaged lift and power unit **(See Fig. 6).**



Fig. 6

3. Open the outer packing carefully **(See Fig. 7).**

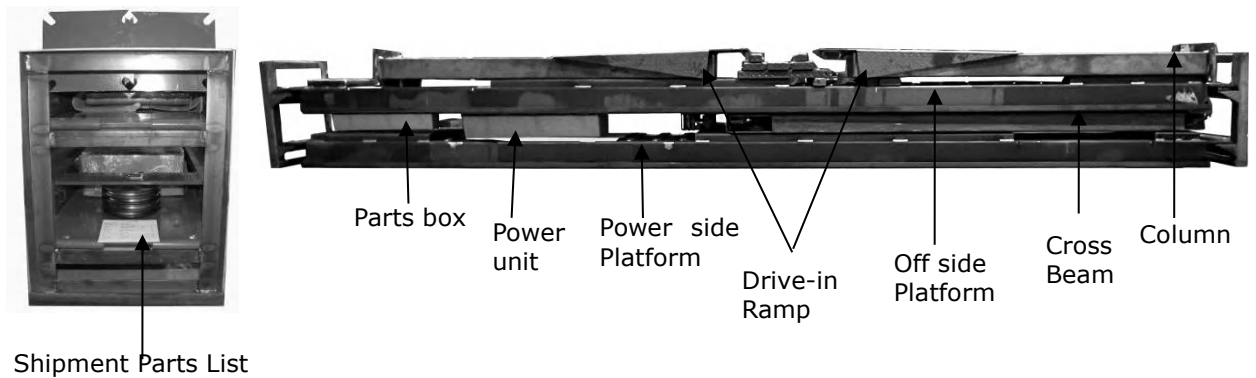


Fig.7

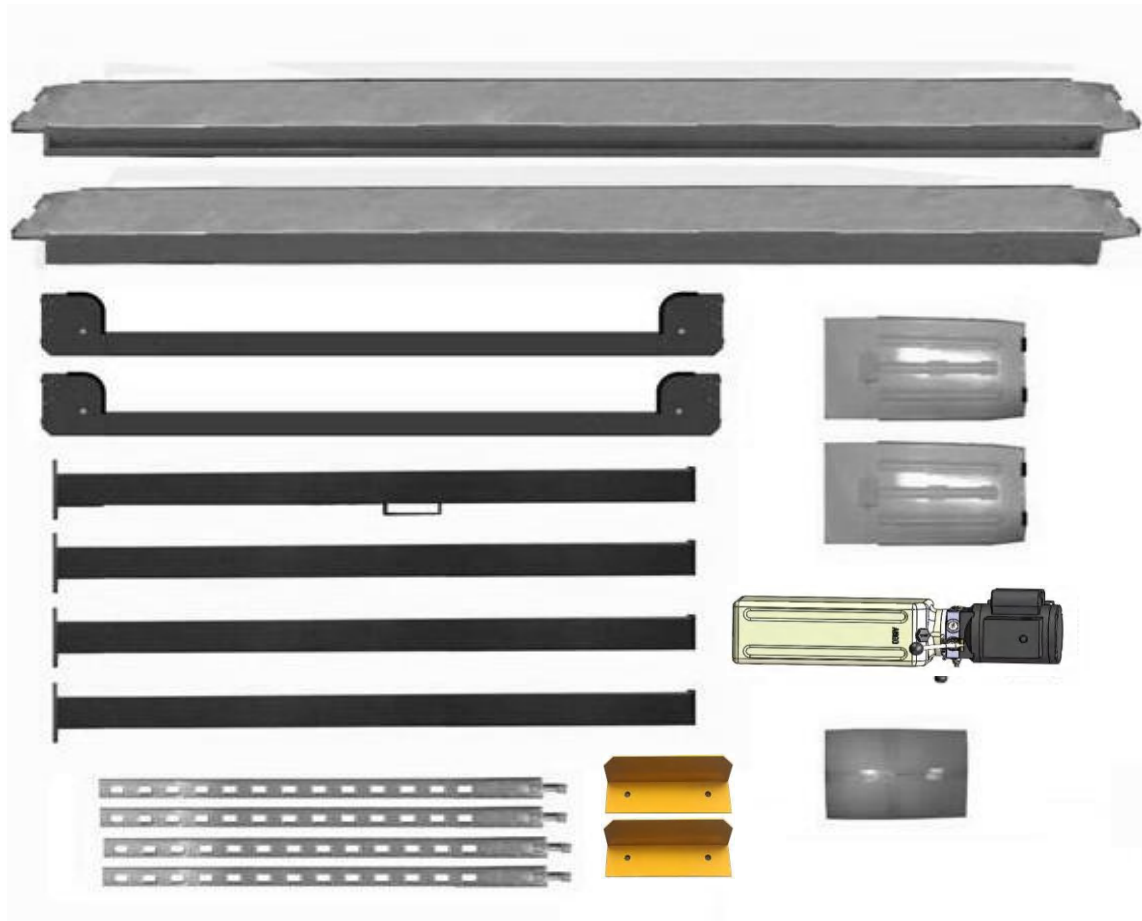
4. Take off the drive-in ramps and columns **(See Fig. 8)**



Fig. 8

5. Loose the screws of the upper package stand, take off the off side platform, take out the parts inside the power side platform, than remove the package stand.
6. Move aside the parts and check the parts according to the shipment parts list
(See Fig. 9, Fig.10).

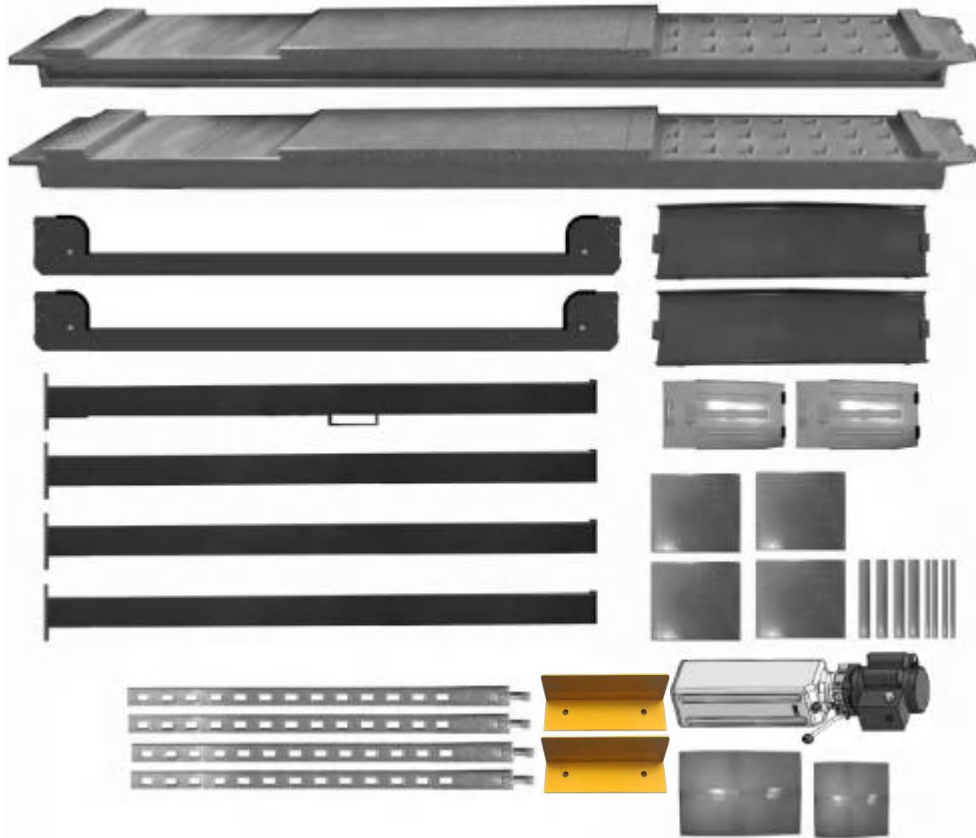
6.1 PRO-14, PRO-14E



PRO-14, PRO-14E

Fig.9

6.2 PRO-14A,PRO-14AE



PRO-14A,PRO-14AE

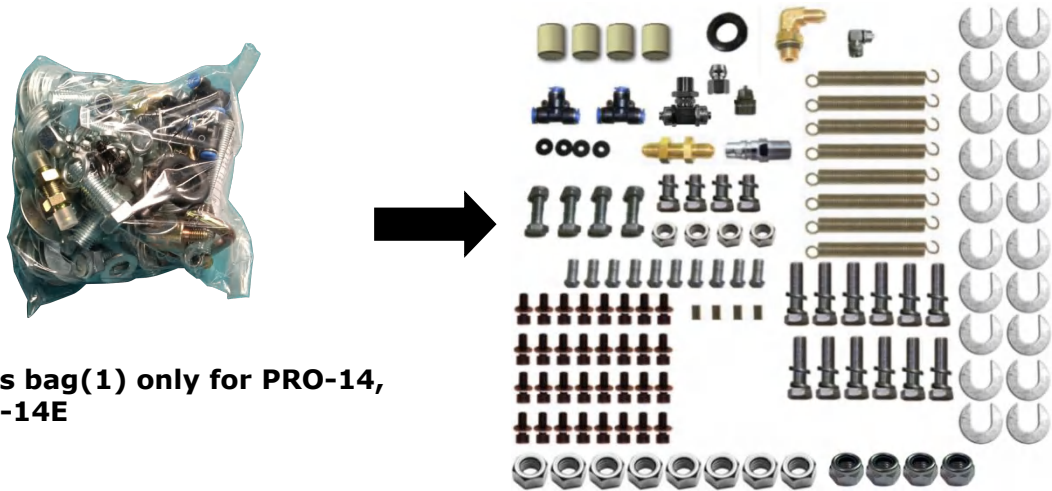
Fig.10

7. Open the carton of parts and check the parts according to the parts box list (See Fig. 11).

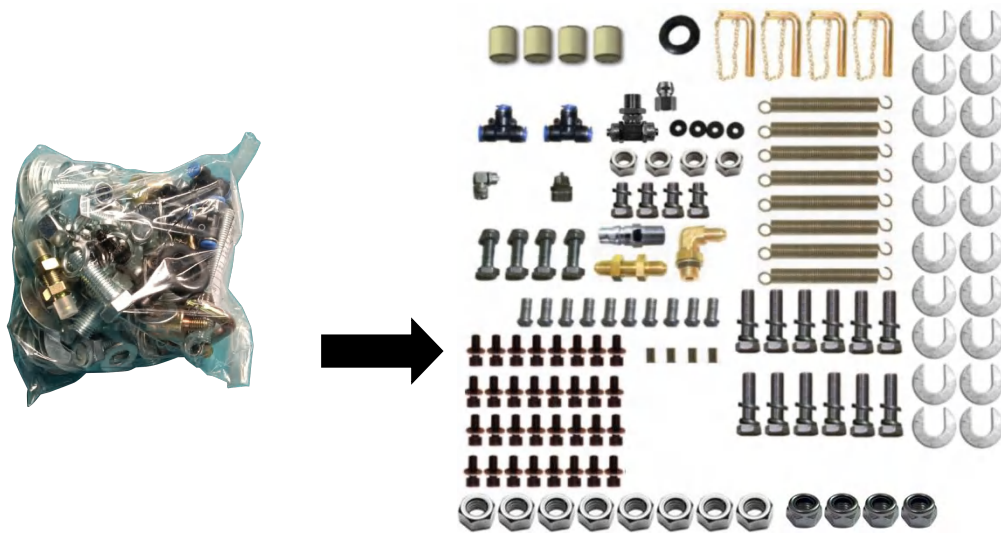


Fig. 11

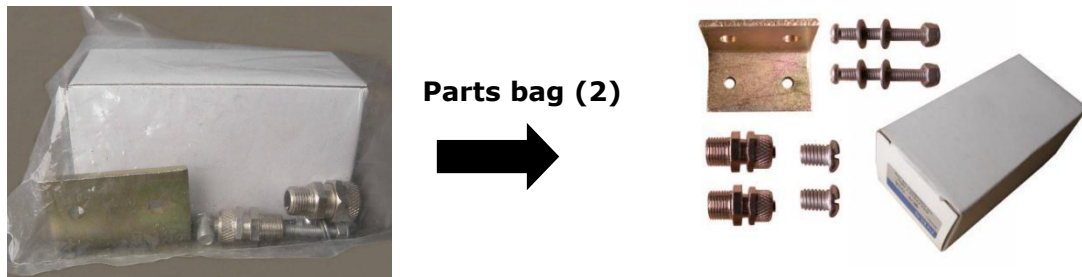
8. Check the parts of the parts bag according to the parts bag list (See Fig. 12).



**Parts bag(1) only for PRO-14,
PRO-14E**



**Parts bag (1) only for PRO-14A,
PRO-14AE**



Parts bag (2)

Fig.12

C. Use a carpenter's chalk line to establish installation layout as per Table 1. Make sure the size is right and base is flat (see Fig. 13).

Note: Reserve space front and behind the installation site.

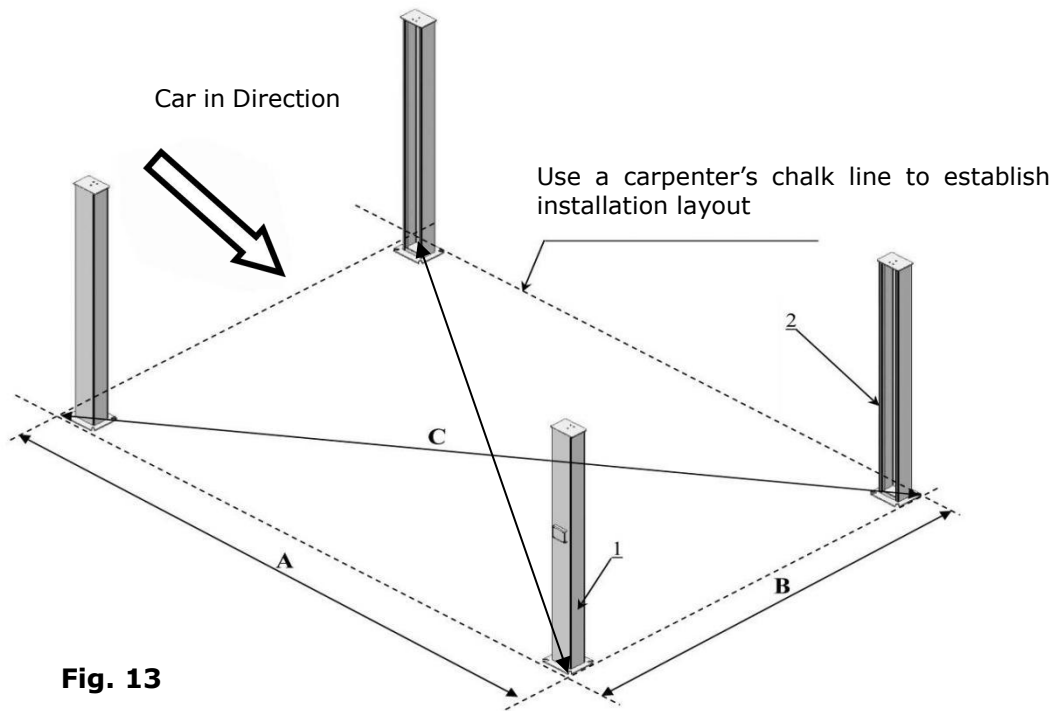


Fig. 13

Model	A	B	C
PRO-14, PRO-14A	217 1/2"	130 7/8"	253 7/8"
PRO-14E, PRO-14AE	246"	130 7/8"	278 11/16"

D. Install Cross Beams (See Fig. 14, Fig. 15).

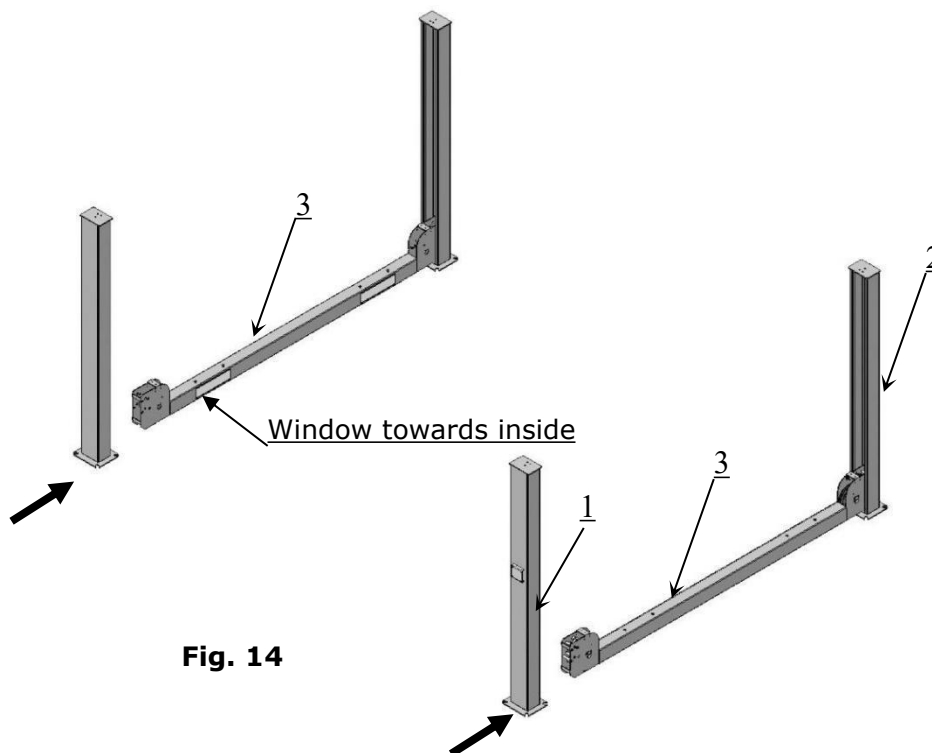


Fig. 14

E. Fix the Anchor Bolts

1. Prepare the Anchor Bolts (See Fig. 15).

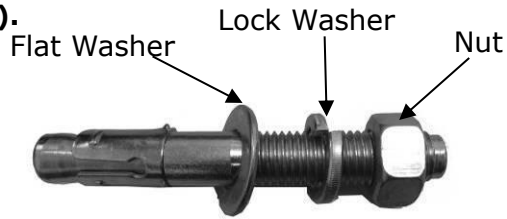


Fig 15

2. Using the prescribed rotary hammer drill, and drill all the anchor holes and install the anchor bolts, do not tighten the anchor bolts first (See Fig. 16).

Note: Anchor bolts driven into the ground at least 3 1/2"

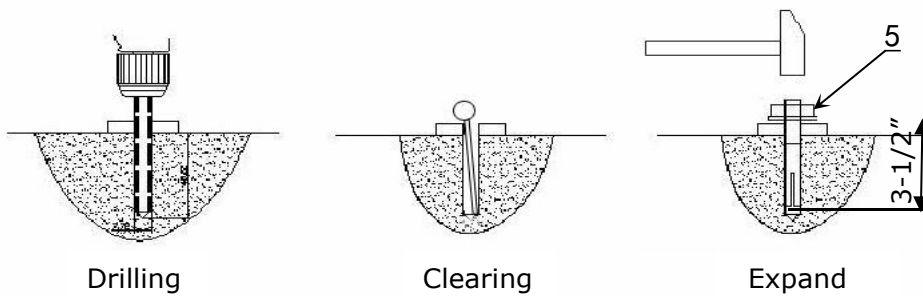


Fig. 16

F. Install the Safety Ladders

1. Adjust the nuts of the four safety ladders to the same position, and then install the safety ladders (See Fig. 17.)

Adjust the nuts on the four safety ladders to the same position, approximately 34mm (1 5/16") from the top.

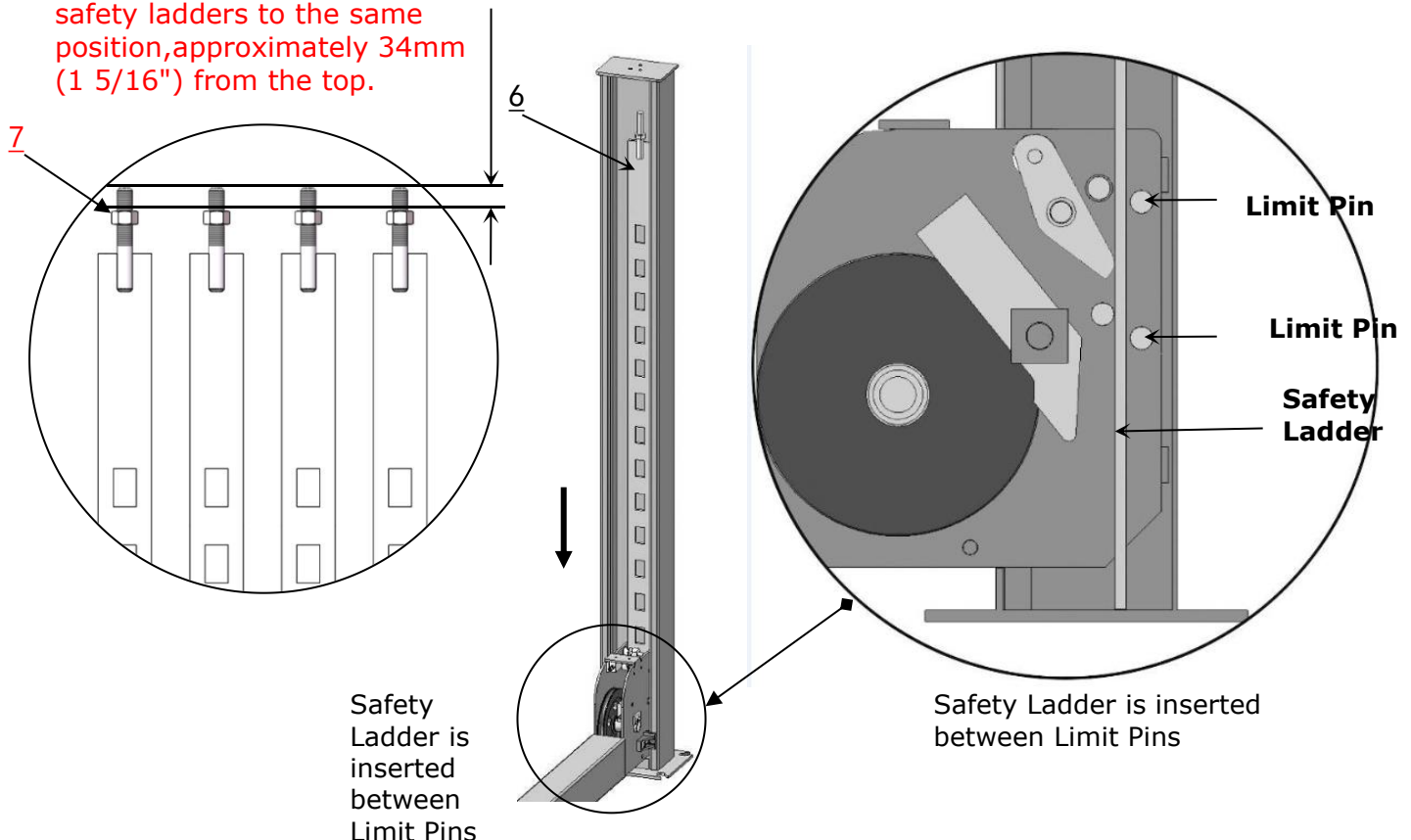
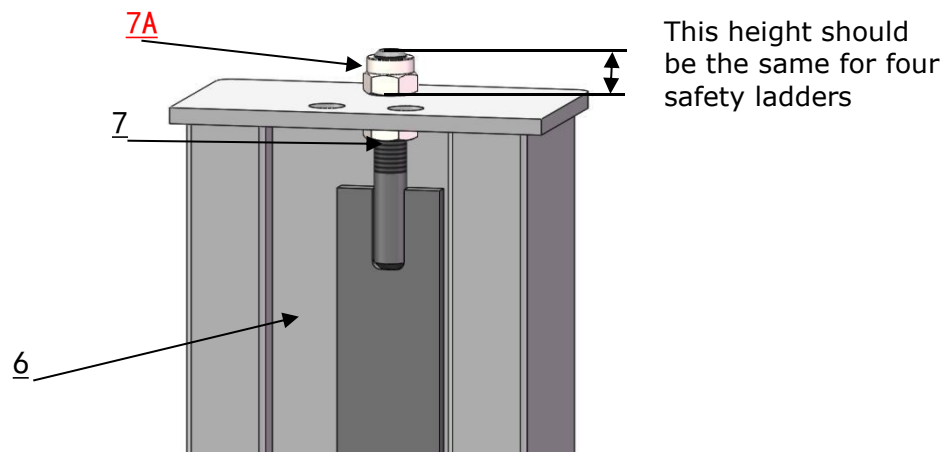


Fig. 17

2. Install safety ladders (See Fig. 18).



Safety ladder pass through the hole of the top plate and the self-locking nut is screwed on. The upper and lower nuts do not need to be tightened.

Fig. 18

G. Raise the cross beams at the same height (See Fig. 19).

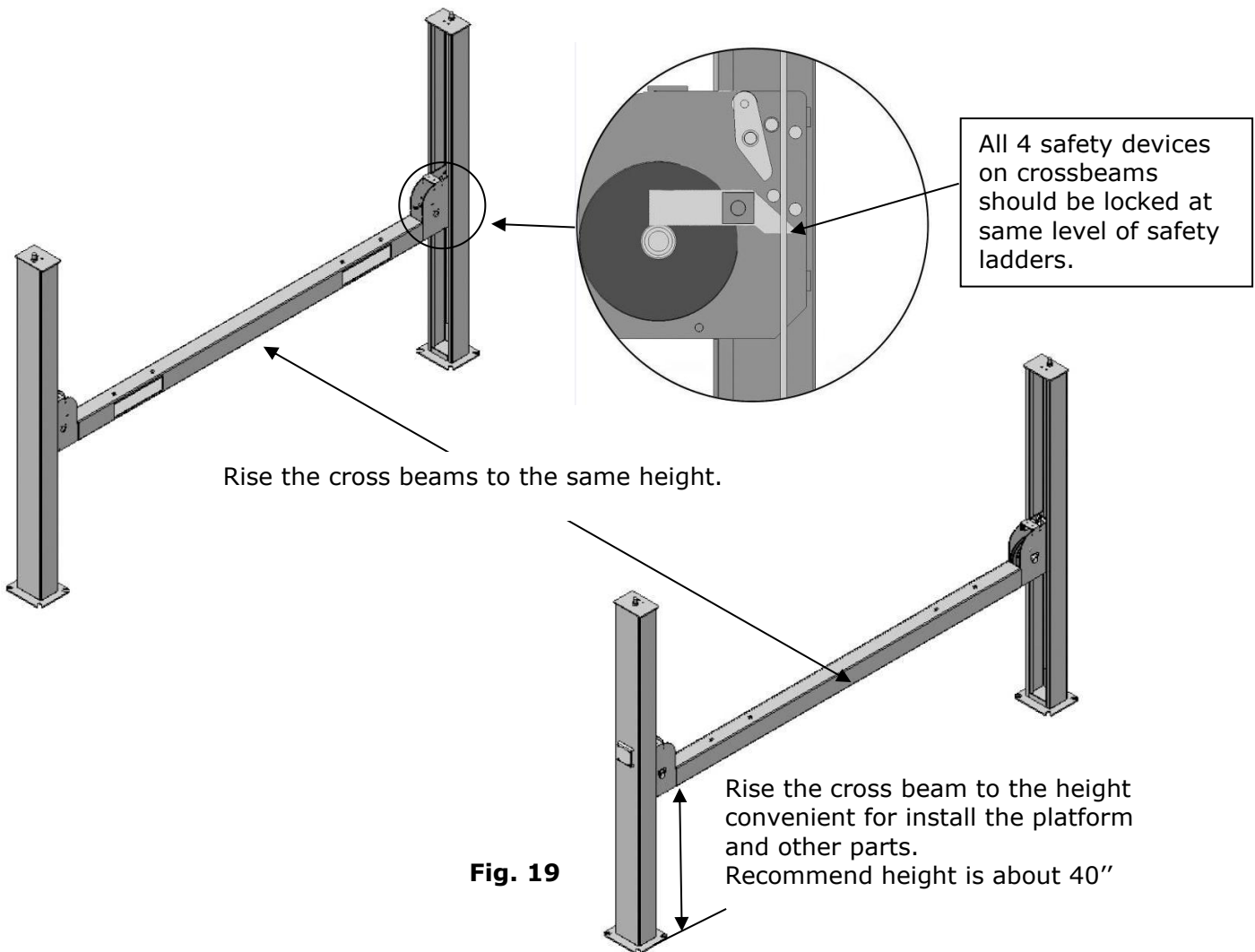


Fig. 19

H. Install platform.

1. Put the power side platform upon the cross beams by fork lift or manual, offset the cross beams to the outside till the pulleys of both platforms can set up into the cross beam (See Fig.20), Install the power side platform and screw up the bolts. (See Fig.21)

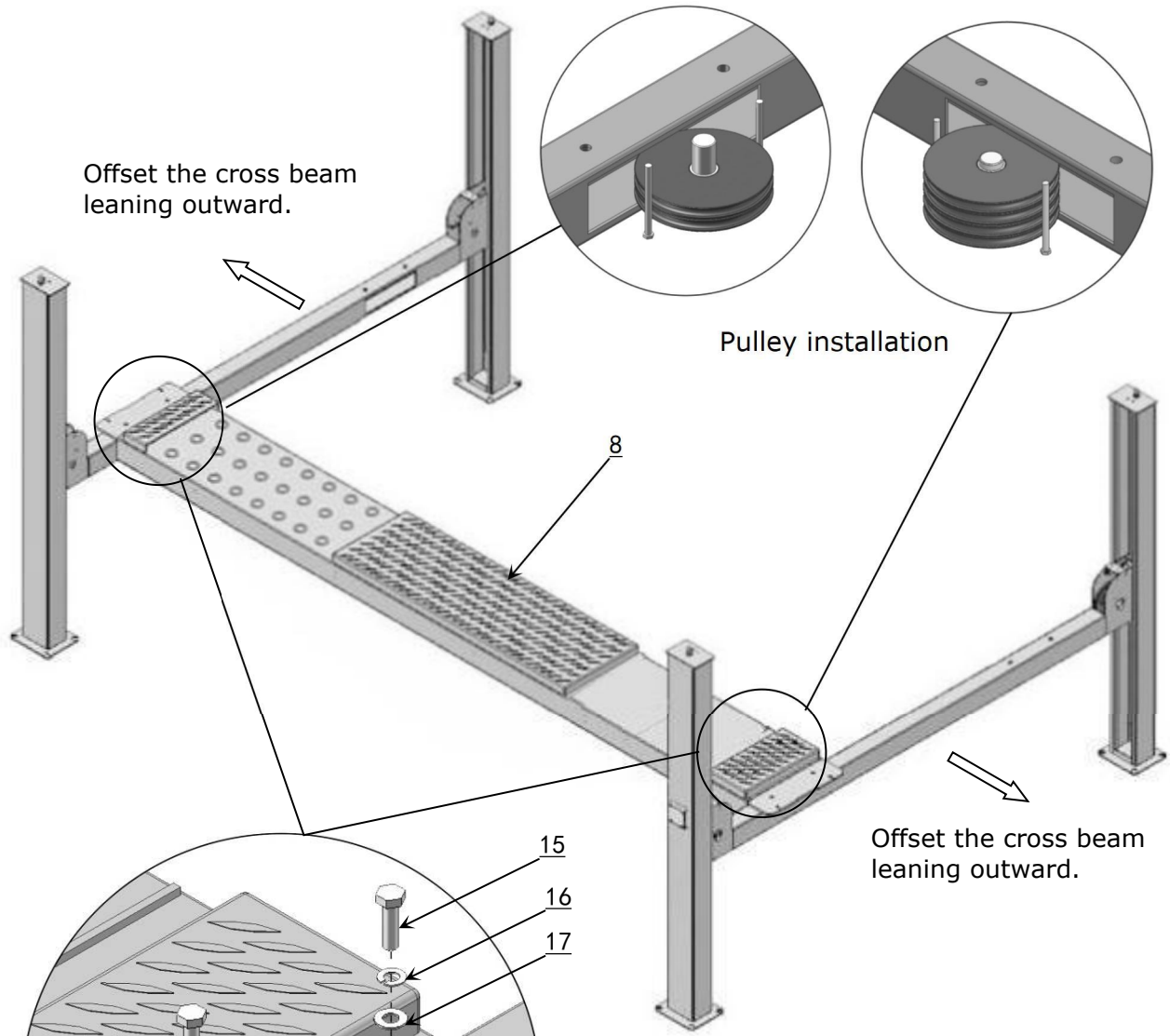


Fig. 20

Tighten the platform and cross beam with bolts M16 * 40

Fig. 21

2. In the same way, place the off side platform on cross beams, align the holes and tighten with bolts (See Fig. 22).

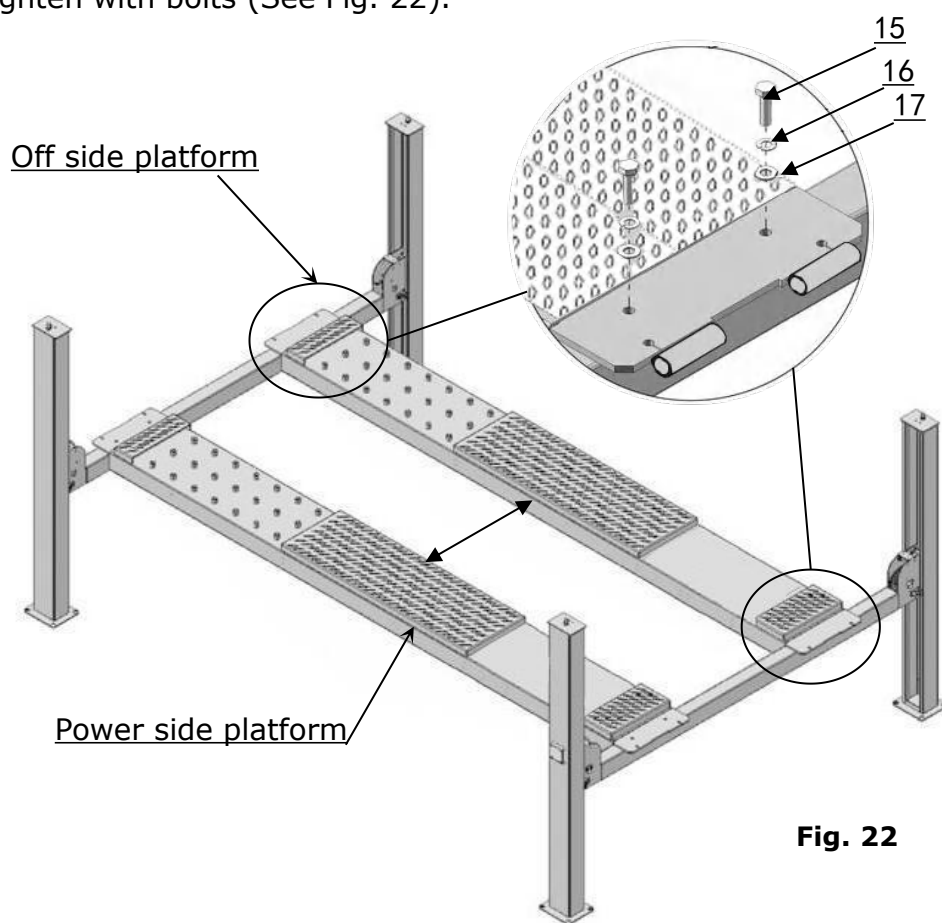


Fig. 22

I. Assembl slider block. check the vertical of columns with level bar, adjust with the shims if not , and then tighten the anchor bolts (See Fig. 23).

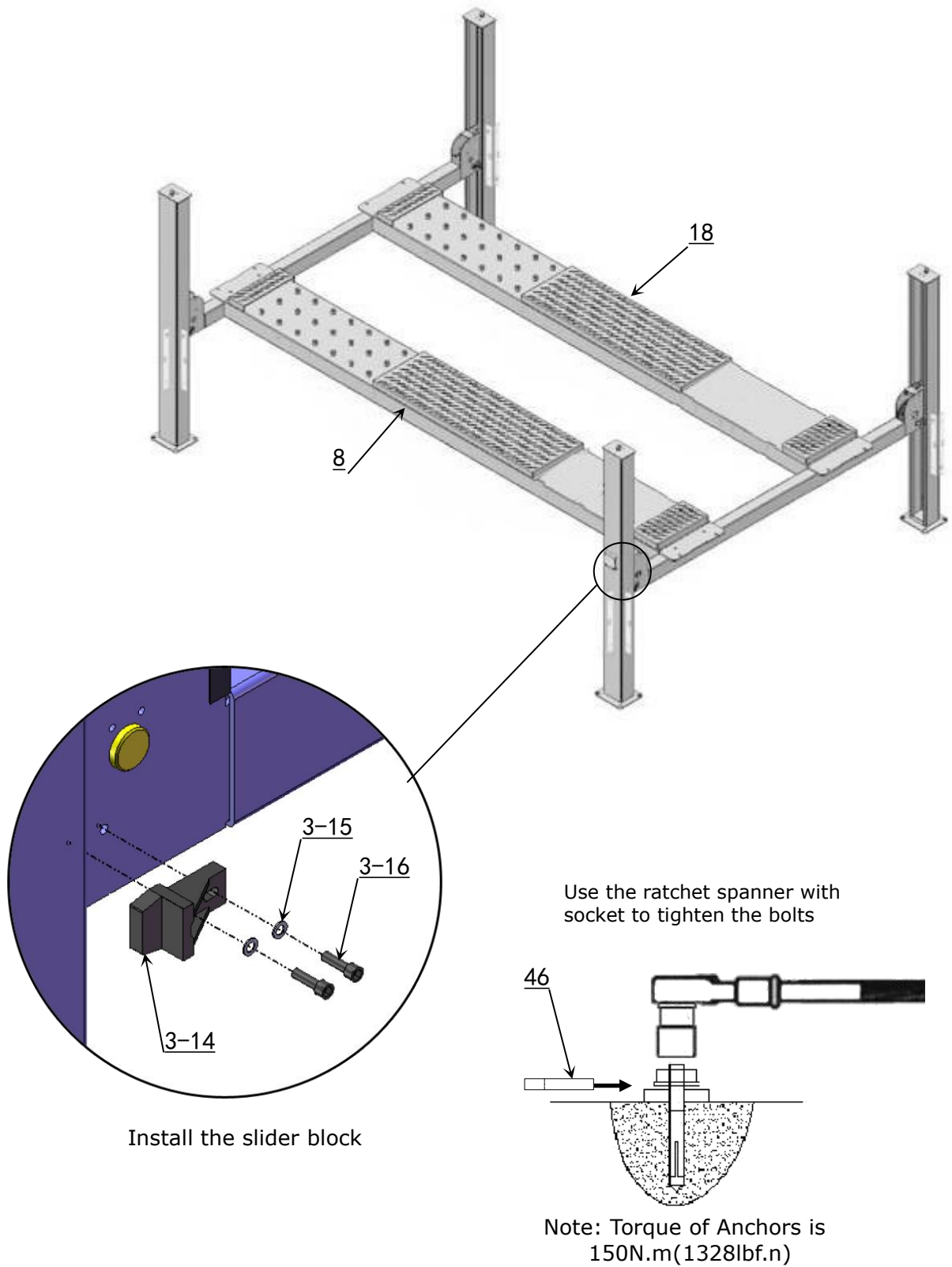
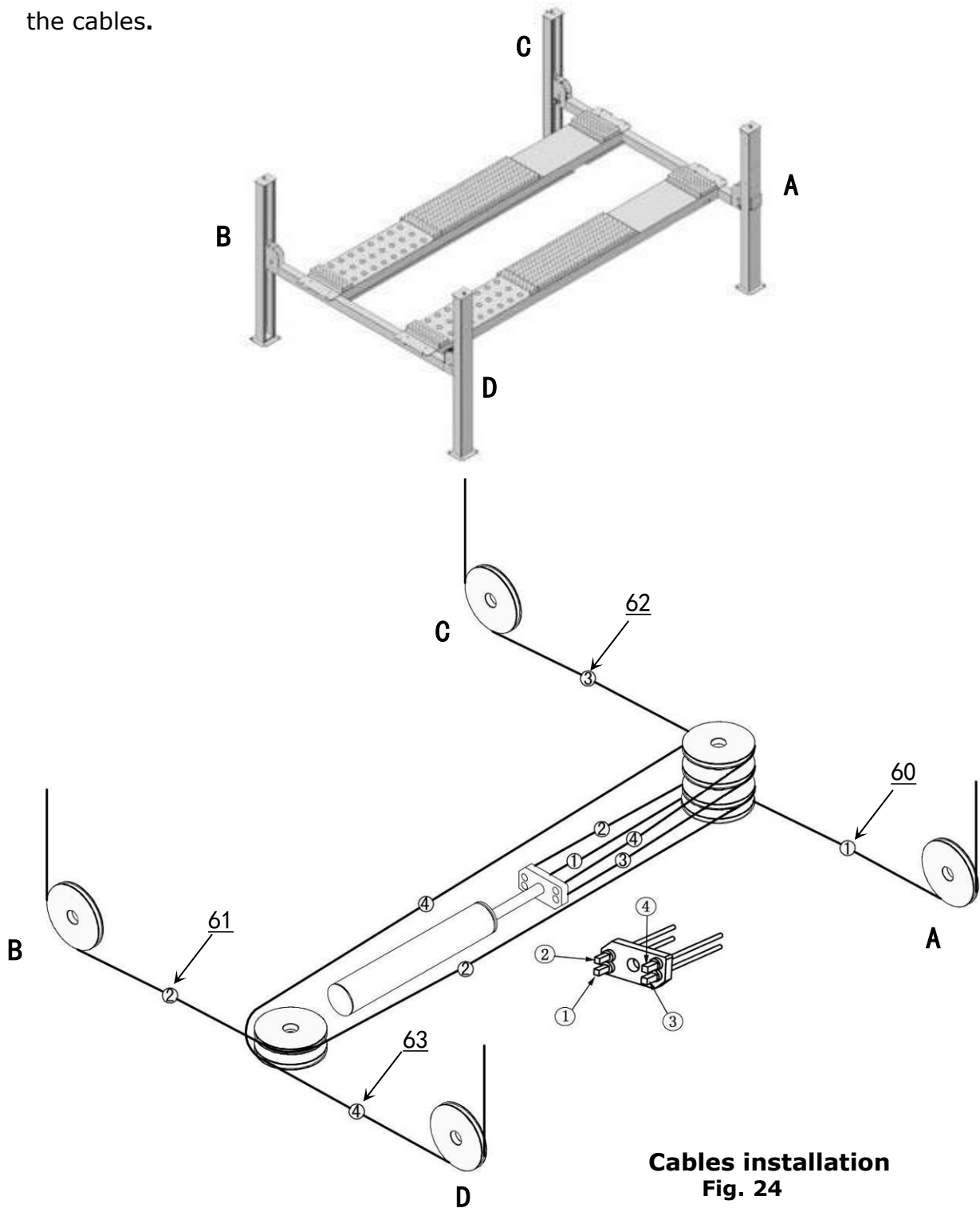


Fig. 23

J. Install cables (See Fig. 24).

1. Pass through the cables from the platform to the columns according to the number of the cables.



**Cables installation
Fig. 24**

Cable \ No.	①	②	③	④
Length PRO-14,PRO-14A (inc. connecting fitting)	163 5/16"	437 3/8"	230"	371 9/16"
Length PRO-14E,PRO-14AE (inc. connecting fitting)	192 1/4"	494 3/16"	257 3/4"	428 7/8"

2. The cable pass through the cross beam to top plate of columns and be screwed with cable nuts, then install cable limit pin (See Fig. 25).

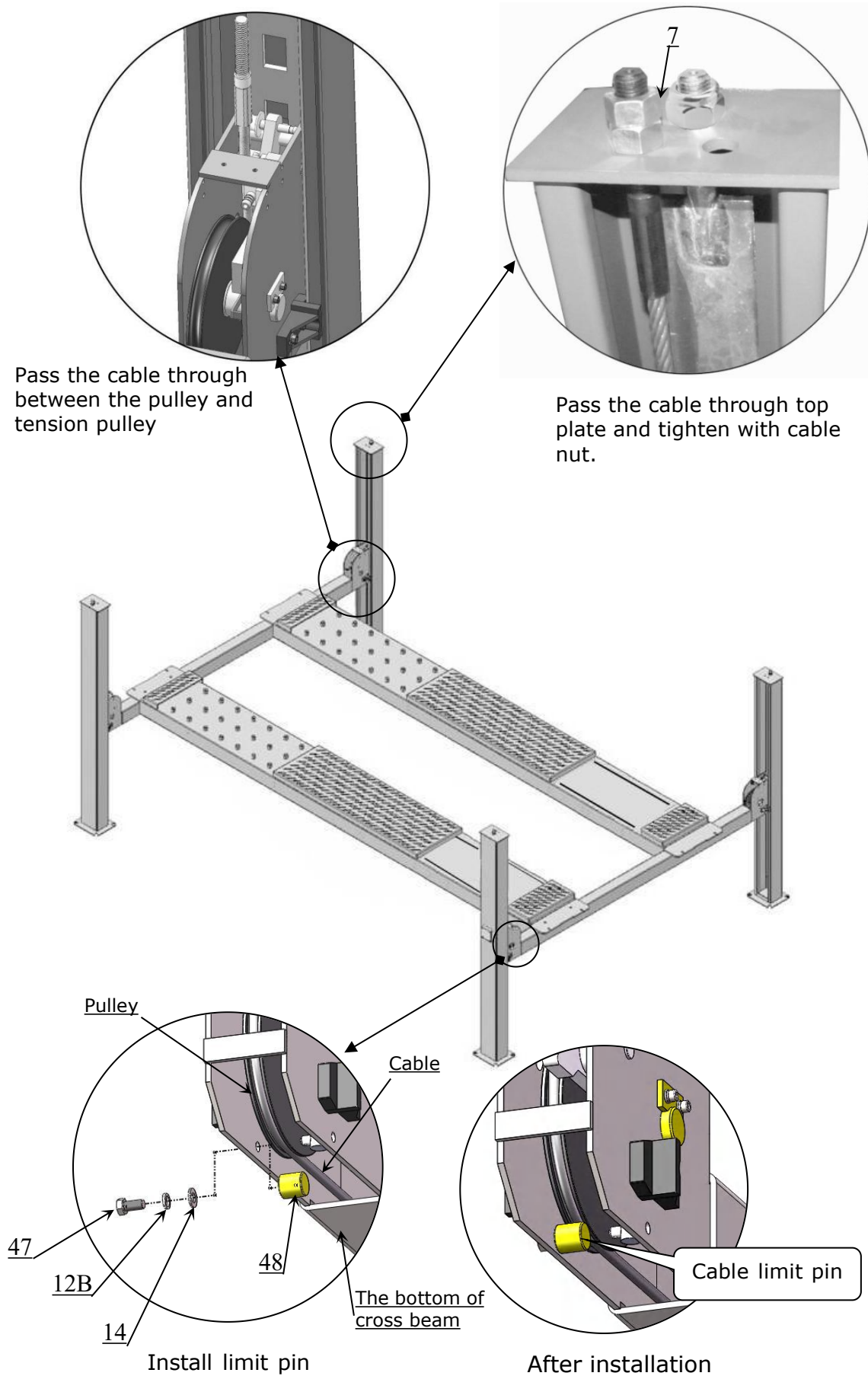


Fig. 25

3. Illustration for platform cables (See Fig. 26).

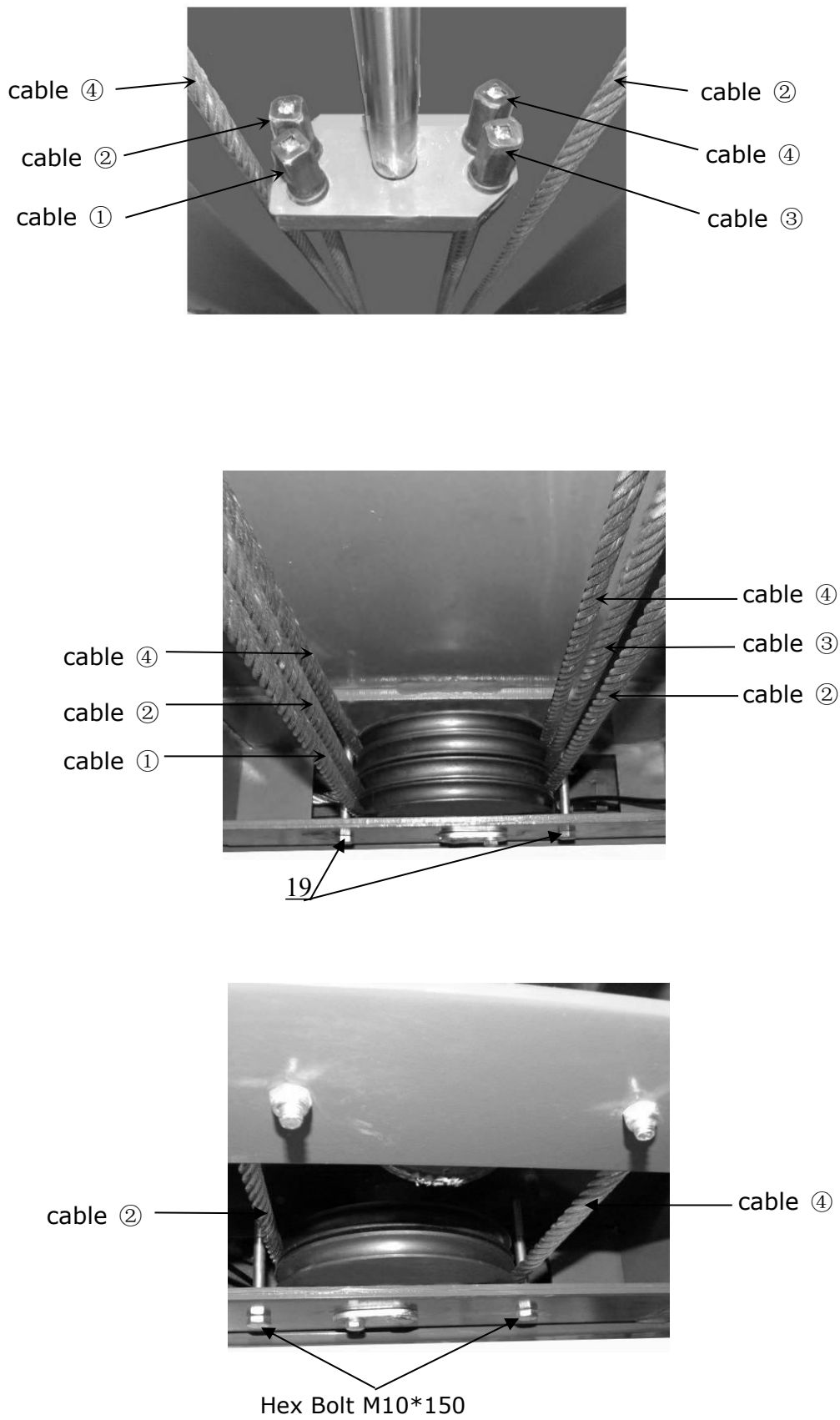


Fig. 26

K. Install Oil-water separator, Manual control air valve and Power unit

(See Fig. 27).

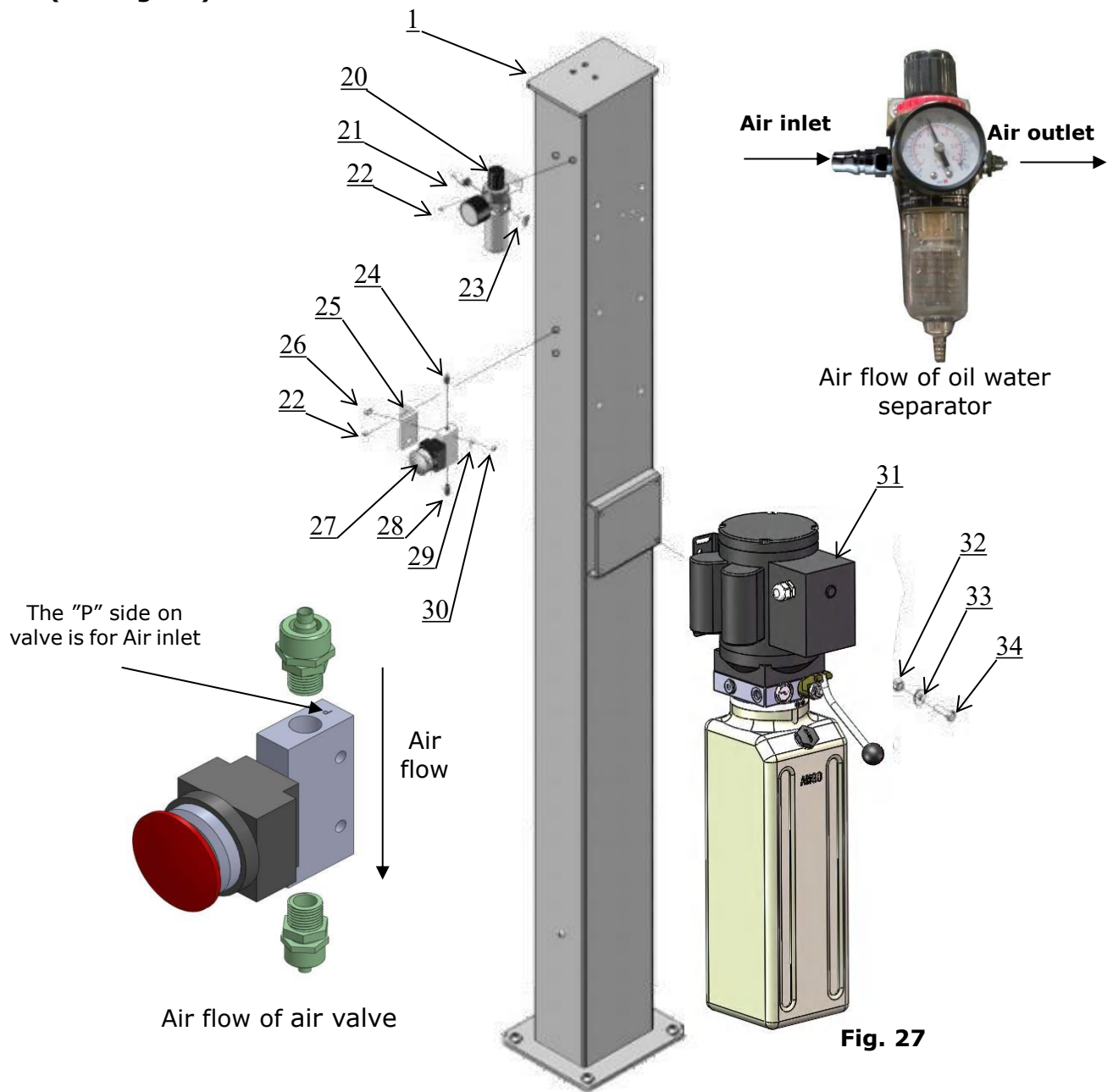


Fig. 27

Item	Part No.	Description	QTY.
20	10420145	Oil-water separator AFR-2000	1
21	1004334013	Straight Fitting for air line	1
22	10209009	Round Head Bolt M6*8	8
23	10420076	Fitting 6*8 screw thread	1
24	10420159	Straight Fitting 6*8 screw thread	1
25	11420160	Fixing plate of Manual Control Valve	1
26	10420161	Self locking nut M4	2
27	10420162	Manual Control Air Valve	1
28	10420163	Straight Fitting for Air Line 6*4 screw thread	1
29	10420148	Flat Washer $\phi 4$	4
30	10420164	Round Head Bolt M4*30	2
31		Manual power unit	1
32	10209005	Nylok Nut M8	4
33	10209004	Rubber Ring	4
34	10209003	Hex Bolt M8*25	4

L. Install Hydraulic System (See Fig. 28).

Note: Oil hoses connected to cylinder must be passed above the cable, cylinder inlet port must swing upward to avoid the oil hose and oil return pipe scratched by cable.

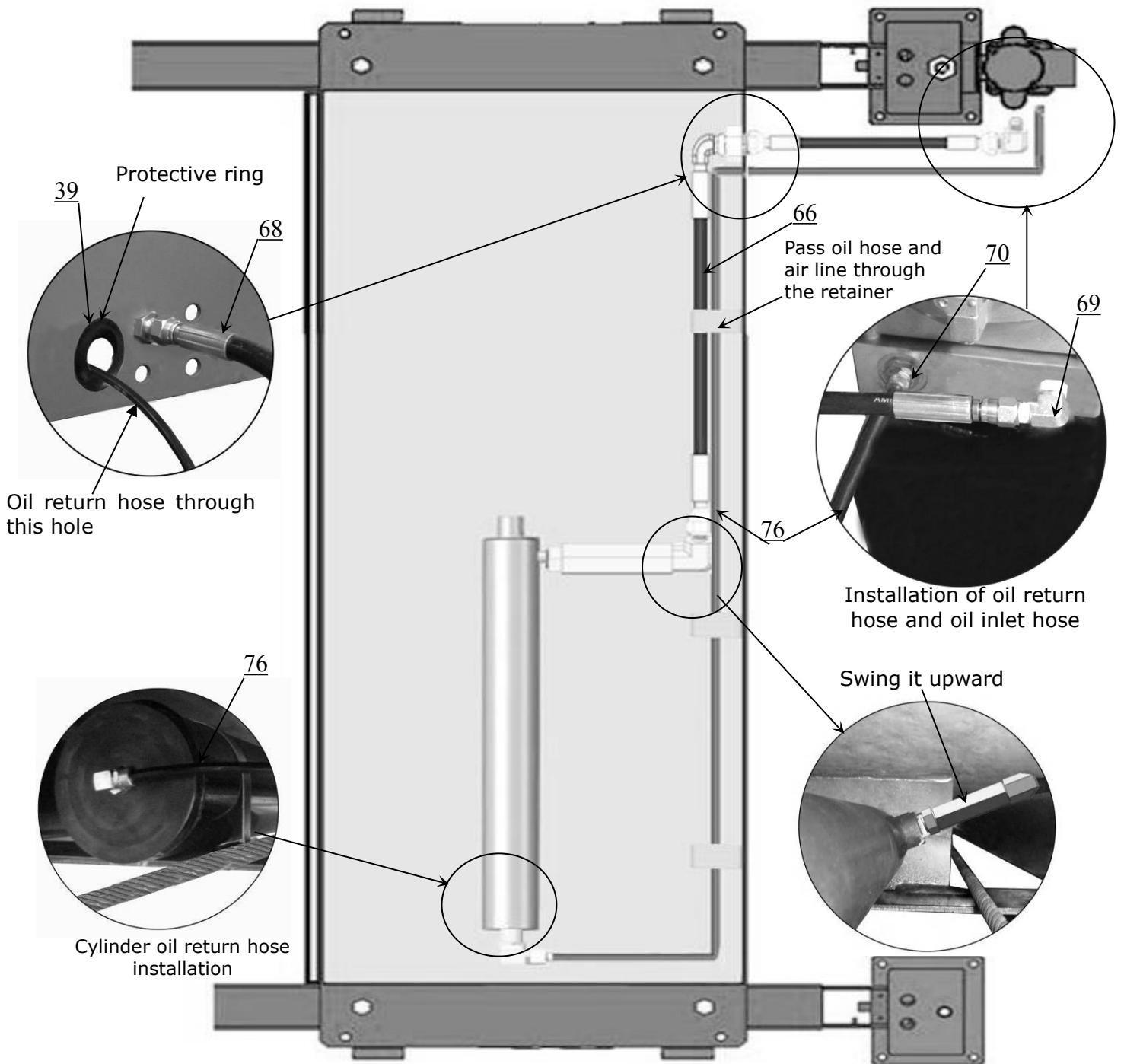
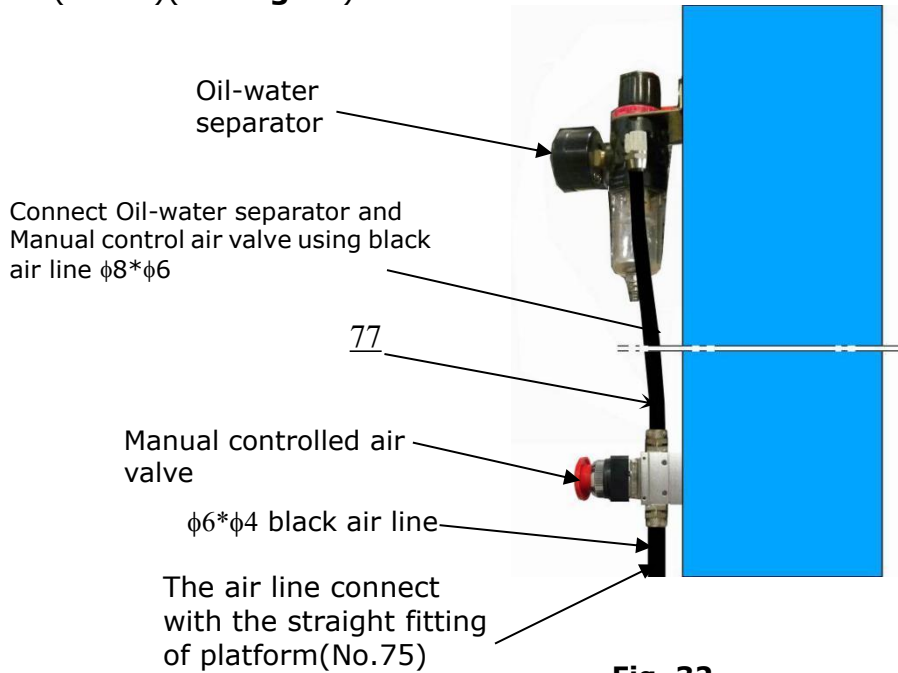
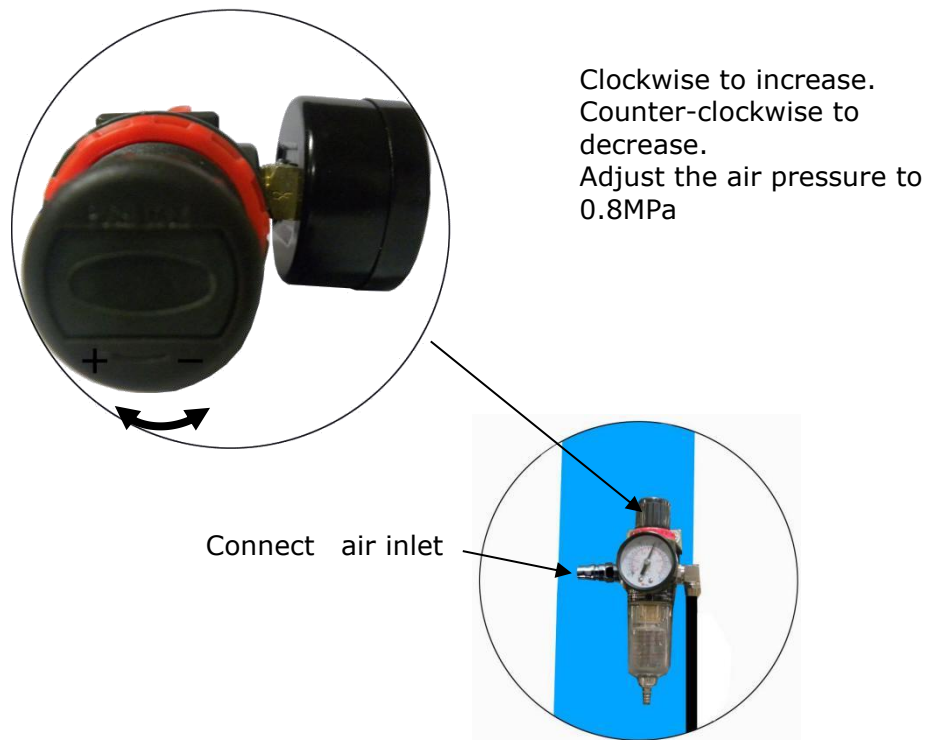


Fig.28

5. Connecting Oil-water separator and manual control air valve with $\phi 8 * \phi 6$ air line(No.77)(see **Fig.32**)



6. Connect air inlet , adjust the air pressure of Oil-water separator to 0.8MPa (**See Fig. 33**).



N. Install Electrical System

Connect the power source on the data plate of Motor.

Note: For the safety of operators, the power wiring must contact the floor well.

Single phase motor (See Fig. 34)

1. Connecting the two power supply wires (hot wire **L1** and hot wire **L3**) to terminals of AC contactor marked L1, L3 respectively.
2. Earth wire(yellow and green wire) is connected with the earth wire terminal of the motor.

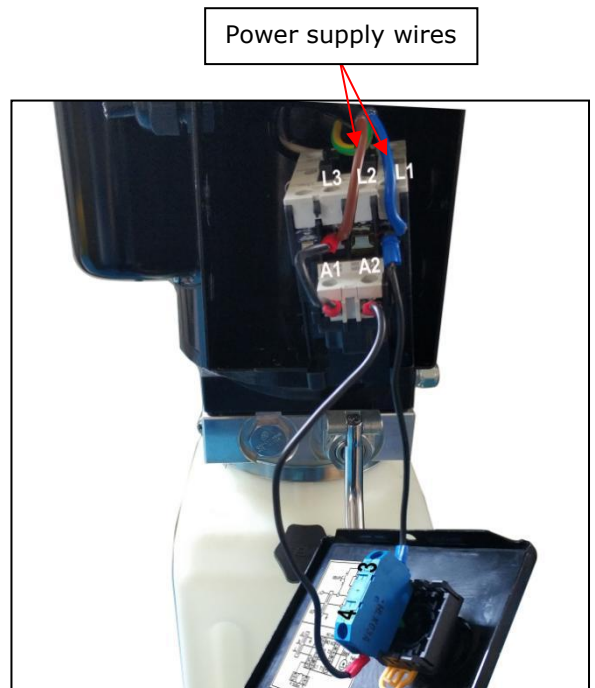
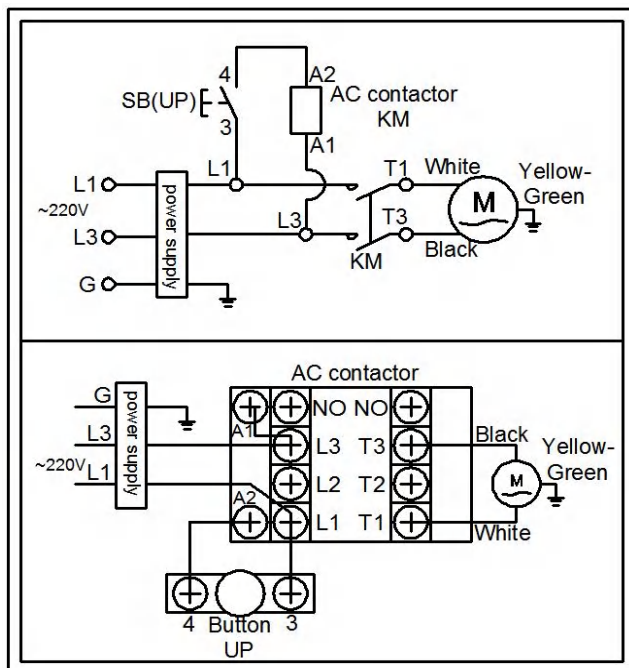


Fig. 34

⚠ DANGER All electrical wiring must be performed by a licensed and certified electrician. Before ensuring the main power has disconnected from the lift and cannot be re-applied until all procedures have been completed, don not perform any maintenance or installation to the lift.

⚠ DANGER Do not use the lift if the wires are damaged or severely worn. If the vehicle rises without noticing damage or extreme wear, carefully lower the vehicle to the ground. Once the lift is on the ground, remove it, disconnect the power, and arrange for protection.

O. Install Spring and Safety Cover of Cross Beam (See Fig. 35).

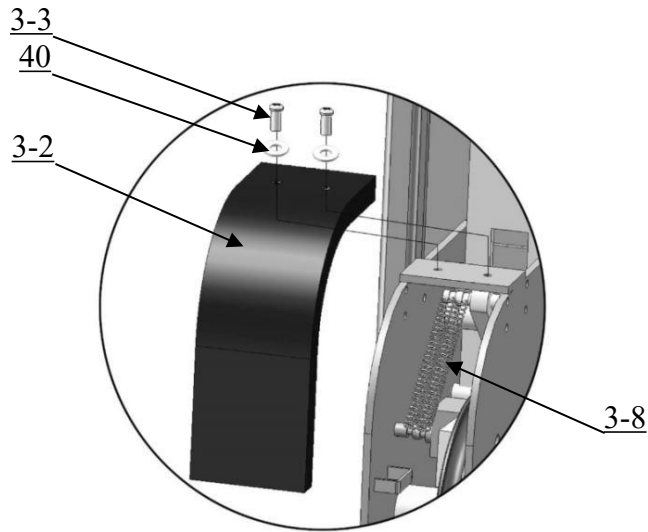
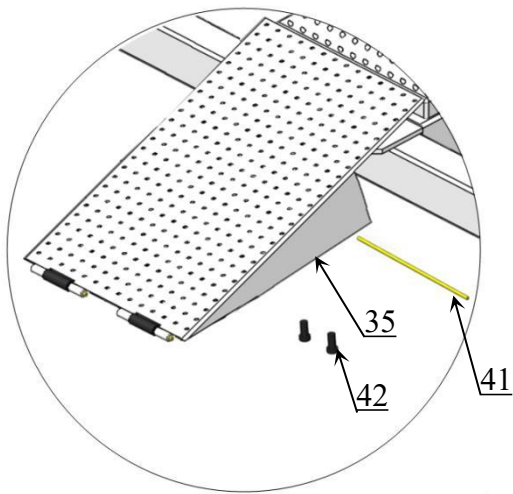


Fig. 35

P. Install Drive-in ramp (See Fig. 36).

Install Drive-in ramp



Drive in ramp assy

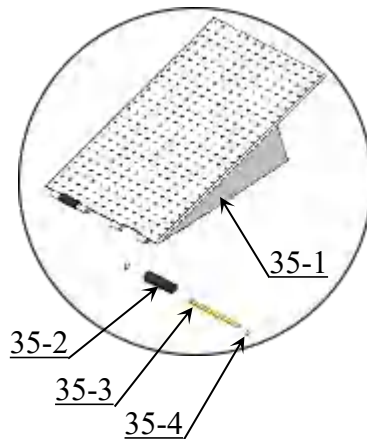
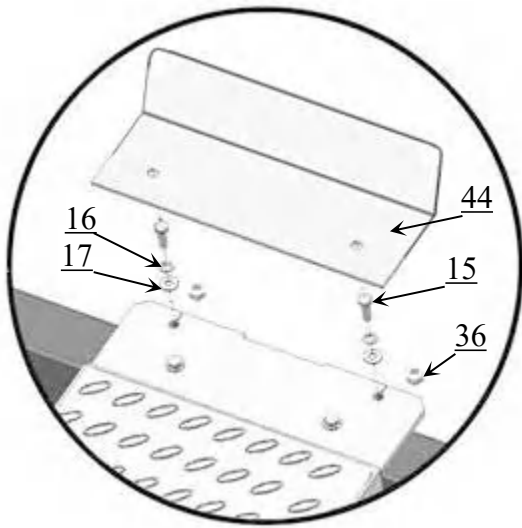


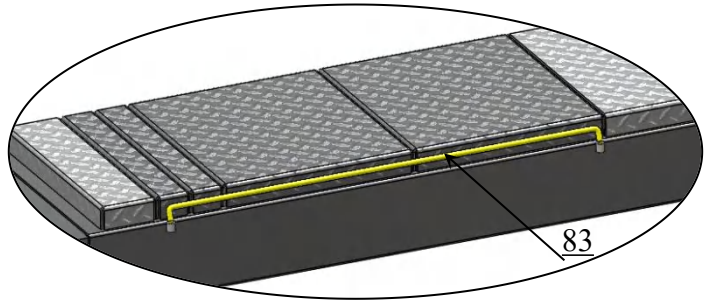
Fig. 36

Item	Part No.	Description	QTY.
35-1	11460028-01	Drive in ramp assy (PRO-14,PRO-14E)	2
	11470003-01	Drive in ramp assy (PRO-14A、PRO-14AE)	2
35-2	11610667	Roller	4
35-3	11620043	Roller pin	4
35-4	10209010	Clip ring	8

Q. Install tire stop plate, turnplate adjustable block, limit rod (See Fig. 37)



Install tire stop plate



After install the turnplate cover and adjustable blocks, install the limit rod.

Fig.37

IV. EXPLODED VIEW

Model PRO-14, PRO-14E

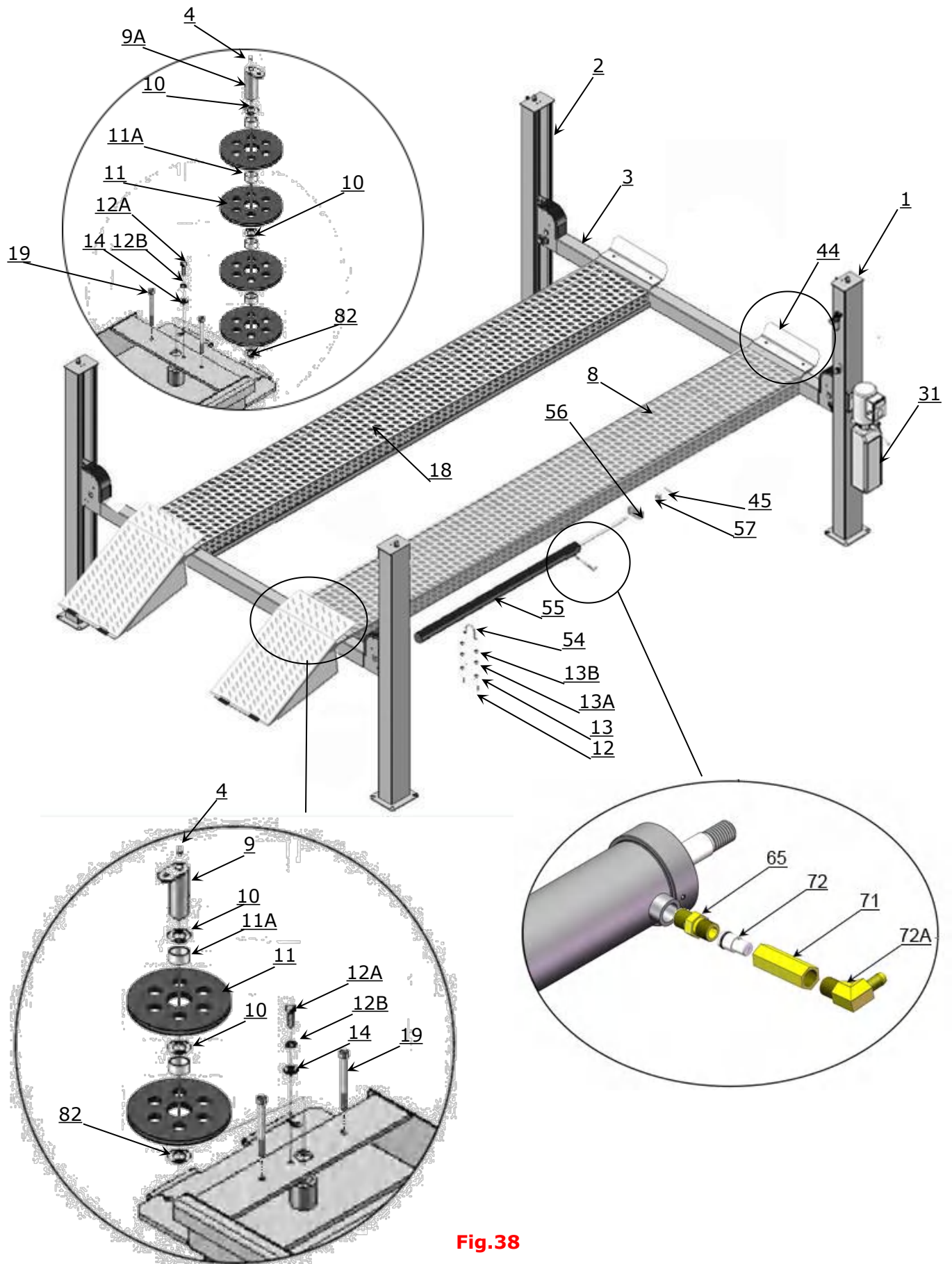
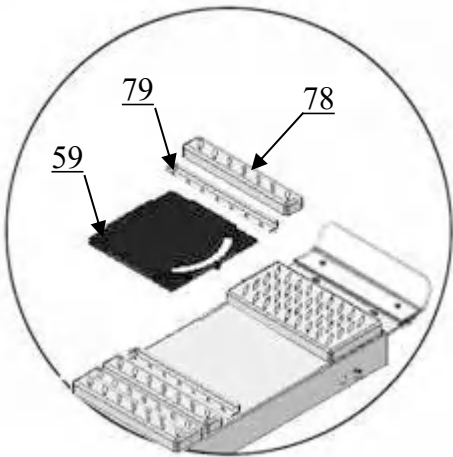


Fig.38

Model: PRO-14A ,PRO-14AE



When installing the turntable both sides are required a 35mm-high turntable block

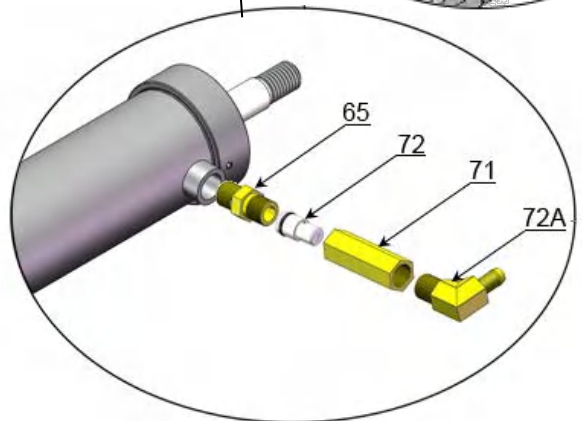
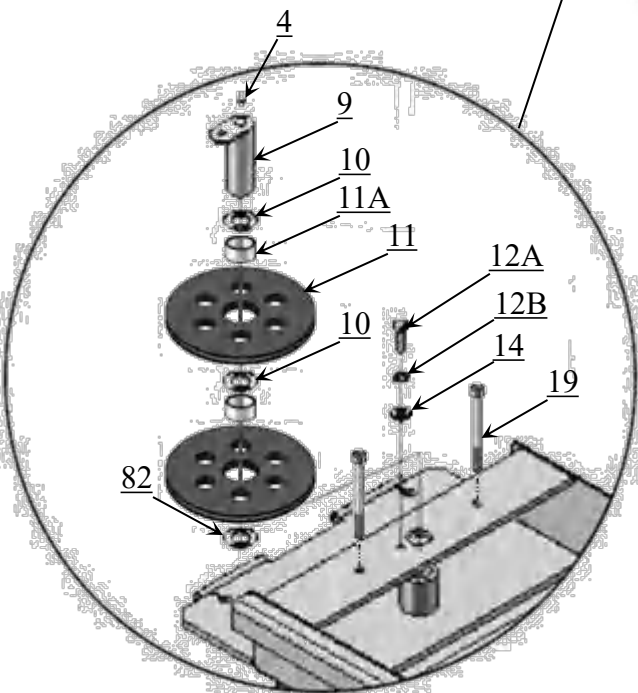
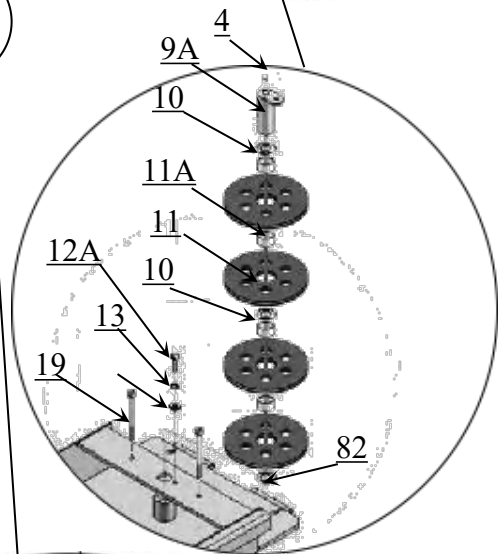
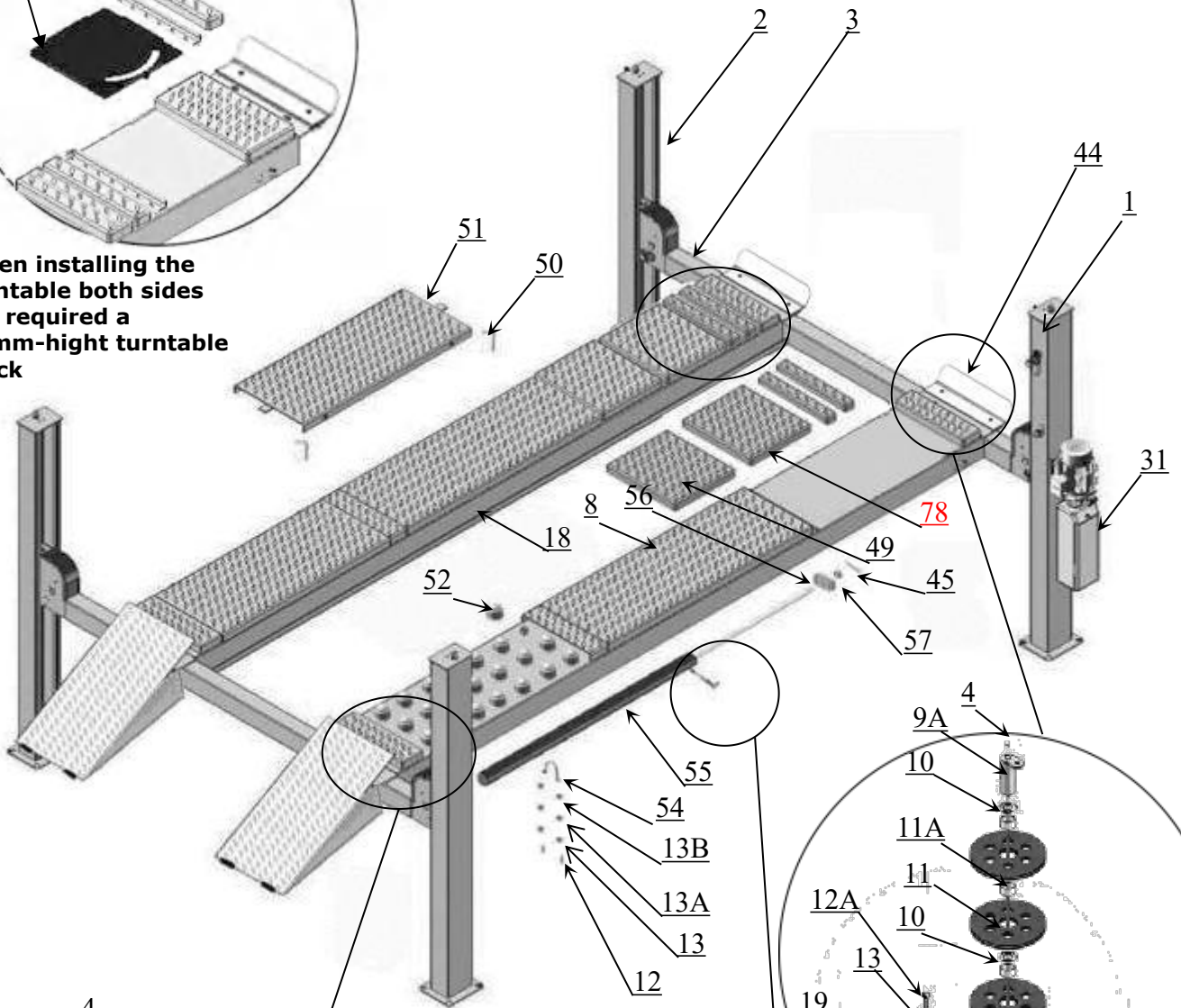


Fig. 39

PARTS LIST

Item	Part No.	Description	PRO-14	PRO-14A	PRO-14E	PRO-14AE
1	1104271001A	Power side Column	1	1	1	1
2	1104271001B	Off side Column	3	3	3	3
3	1104272001C	Cross Beam assy.	2	2	2	2
4	10620064	Grease fitting	6	6	6	6
5	10209059	Anchor bolt 3/4*5 1/2	16	16	16	16
6	1104271004A	Safety ladder	4	4	4	4
7	10476014	Hex nut M22	12	12	12	12
7A	40100014	Self-lock nut M22	4	4	4	4
8	11460054-04	Power side platform	1	0	0	0
	11460024-04		0	1	0	0
	11460095-04		0	0	1	0
	11470007-04		0	0	0	1
9	1104143002A-01	Pulley pin	1	1	1	1
9A	1104143001A-01		1	1	1	1
10	10476029	Pulley washer (HK016)	4	4	4	4
11	11476636-01	Pulley	6	6	6	6
11A	1004094002	Bush	10	10	10	10
12	10209043	Hex bolt M8*20	2	2	2	2
12A	1004514007	Hex bolt M10*20(class 8.8)	2	2	2	2
12B	10209039	Flat washer φ10	6	6	6	6
13	10209034	Lock Washer φ8	2	2	2	2
13A	10209033	φ8 flat washer	10	10	10	10
13B	10217002	Hex nut M8	2	2	2	2
14	10209022	Flat washer φ10	6	6	6	6
15	10420030	Hex bolt M16*40	12	12	12	12
16	1020114	Lock washer φ20	8	8	8	8
17	10209128	Flat washer φ20	8	8	8	8
18	11460055-03	Off side platform	1	0	0	0
	11460026-03		0	1	0	0
	11460096-03		0	0	1	0
	11470008-03		0	0	0	1
19	10476015	Socket bolt M10*150	4	4	4	4
20	10420145	Oil-water Separator AFR-2000	1	1	1	1
21	1004334013	Quick fitting (1/4NPT)	1	1	1	1
22	10209009	Round head bolt M6*8	8	8	8	8
23	10420076	Straight fitting	1	1	1	1
24	10420159	Straight fitting	1	1	1	1
25	11420160	Mounting plate of Manual control air valve	1	1	1	1
26	10420161	Nylok nut M4	2	2	2	2
27	10420162	Manual control air valve	1	1	1	1
28	10420163	Straight fitting	1	1	1	1
29	10420148	Flat washer φ4	4	4	4	4
30	10420164	Round head bolt M4*30	2	2	2	2
31		Manual power unit	1	1	1	1

Item	Part No.	Description	PRO-14	PRO-14A	PRO-14E	PRO-14AE
32	10209005	Nylok Nut M8	4	4	4	4
33	10209004	Rubber Ring	4	4	4	4
34	1061K050	Hex Bolt M8*30	4	4	4	4
35	11460636-01	Drive-in ramp	2	0	2	0
	86010608-01		0	2	0	2
36	10209066	Hex Nut M16	4	4	4	4
39	10420156	Protective ring	1	1	1	1
40	10420045	Flat Washer φ6	20	20	20	20
41	11420004	Pin for Drive-in Ramp	2	2	2	2
42	10420005	Set screw M5*8	4	4	4	4
43	1004274003	Parts box	1	0	0	0
	1004284003		0	1	0	0
	1004464001		0	0	1	0
	1004474001		0	0	0	1
44	11420031-1	Tire stop plate	2	2	2	2
45	10201005	Cotter pin	1	1	1	1
46	10201090	Shim (1mm)	20	20	20	20
	10620065	Shim (2mm)	20	20	20	20
47	10206017	Hex bolt M10*20	4	4	4	4
48	11420217-01	Cable Limit Pin	4	4	4	4
49	11430004	Turnplate cover	0	4	0	4
50	11520037	Split pin	0	4	0	4
51	11450003	Slip Plate	0	2	0	2
52	10420157	Steel Ball Set	0	60	0	60
54	11460029	Fixing Ring For Oil Cylinder	1	1	1	1
55	C804408	Cylinder	1	1	1	1
56	11460078	Cable connecting plate	1	1	1	1
57	10420014	Hex Nut M27	1	1	1	1
58	10420016B	Bellow pipe	1	1	1	1
59	40101	Turnplate(optional)	0	2	0	2
60	10460066-01	No.① Cable	1	1	0	0
	10460087-01		0	0	1	1
61	10460069-01	No.② Cable	1	1	0	0
	10460090-01		0	0	1	1
62	10460067-01	No.③ Cable	1	1	0	0
	10460088-01		0	0	1	1
63	10460068-01	No.④ Cable	1	1	0	0
	10460089-01		0	0	1	1
64	10420166	90° Fitting	1	1	1	1
65	11420243	Straight fitting	1	1	1	1
66	10460060	Oil hose assy.	1	1	0	0
	10460091		0	0	1	1
67	10420120	Extended Straight Fitting (with Nut)	1	1	1	1
68	10460038	Oil Hose assy. L=59 1/16"	1	1	1	1
69	10209060	90° fitting	1	1	1	1
70	10420095	Straight fitting	1	1	1	1

Item	Part No.	Description	PRO-14	PRO-14A	PRO-14E	PRO-14AE
71	11420245	Straight Fitting	1	1	1	1
72	C802004	Compensation Valve	1	1	1	1
72A	10201020	90° Fitting	1	1	1	1
73	10420124	T-Fitting For Air Line	2	2	2	2
74	1004014007	T-Fitting	1	1	1	1
74A	1004014008	Thin nut G1/4	1	1	1	1
75	10420241	Straight Fitting	1	1	1	1
76	10476007	Oil Return Hose L=263"black	1	1	0	0
	10460092	Oil Return Hose L=286 7/16"black	0	0	1	1
76A	10460013	Black Air Line L=321"	1	1	0	0
	10460094	Black Air Line L=350 3/8"	0	0	1	1
77	10420167A	Black Air Line L=18 1/8"	1	1	1	1
78	11480033	Turnplate adjustable block	0	4	0	4
79	11480045	Turnplate adjustable block	0	4	0	4
80	1004094001	Bush	4	4	4	4
81	11476635	Pulley	4	4	4	4
82	10476024	Washer for Pulley	8	8	8	8
83	10400303001	limit Rod	0	4	0	4

4.1 CROSS BEAM EXPLODED VIEW (1104272001C)

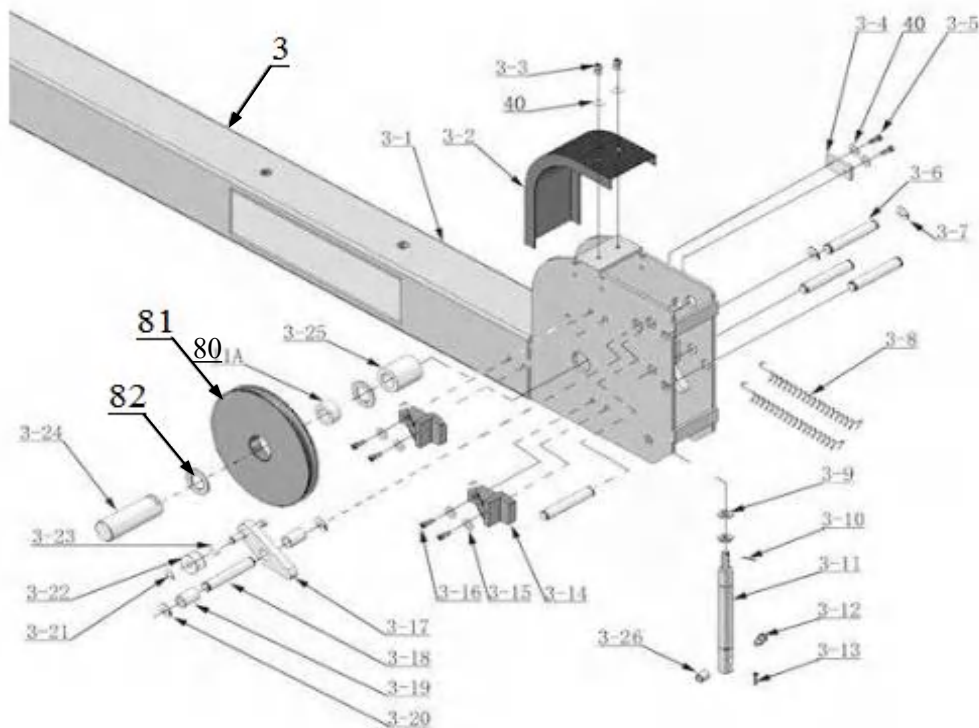


Fig. 40

Item	Part No.	Description	Qty
3-1	1104272001B	Cross Beam	2
3-2	1004272001	Protective cover	4
3-3	10209009	Round head bolt M6*8	8
3-4	11420044	Limit plate	4
3-5	10420138	Socket bolt M6*16	8
3-6	1104272012	Pin	12
3-7	10420037	Clip ring	24
3-8	10480113	Spring	8
3-9	10209021	Hex Nut M10	8
3-10	10420049	Cotter pin	4
3-11	10420048	Air Cylinder	4
3-12	10420047	Fitting for Air Cylinder	4
3-13	10420046	Cotter Pin	8
3-14	10420042	Slider	16
3-15	10209033	φ8 flat washer	32
3-16	10420043	Socket Bolt M8*20	32
3-17	1104272009A-L	Safety block 2 (left)	2
	1104272009A-R	Safety block 2 (right)	2
3-18	1104272011	Pin	8
3-19	1104272013	Pin bush	8
3-20	85090579	Clip ring	16
3-21	10209010	Clip ring	4
3-22	10420035	Tension Pulley	4
3-23	1104272017	Spacer	4
3-24	1104272014	Pulley Pin	4
3-25	1104272015	Pulley pin bush	4
3-26	1104272016	Spacer	4

4.2 CYLINDERS EXPLODED VIEW **C804408 (Old code 10460030-01)**

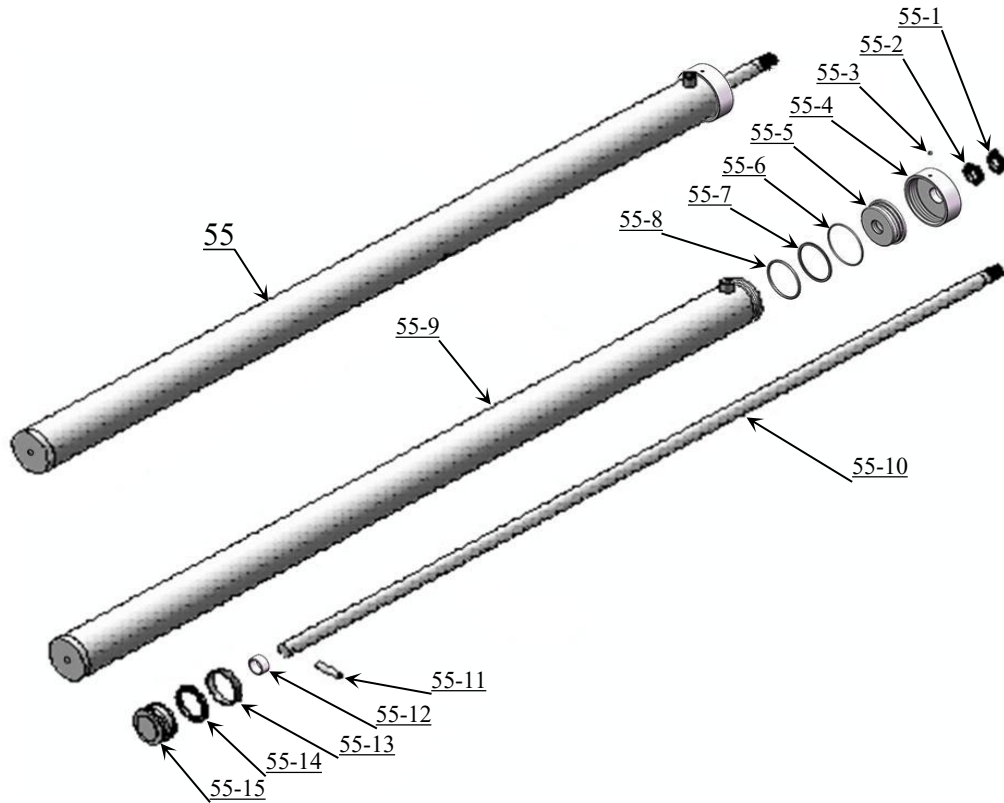


Fig. 41

Item	Part No.	Description	Qty
55-1	10420059	Dust Ring	1
55-2	1004016001	Y- Ring USH	1
55-3	1004144002	Set screw	1
55-4	1104146001	Head Cap	1
55-5	1104146002	Seal sleeve	1
55-6	1004146001	O- Ring	1
55-7	1004146002	Support Ring	1
55-8	1004146003	O- Ring	1
55-9	11460048-01	Bore Weldment	1
55-10	11420064	Piston Rod	1
55-11	11460050	Pin	1
55-12	1104146003	Adjusting sleeve	1
55-13	10460051	Support Ring	1
55-14	10460052-01	Y- Ring USH	1
55-15	11460053-01	Piston	1

4.3 Illustration of hydraulic valve for power unit

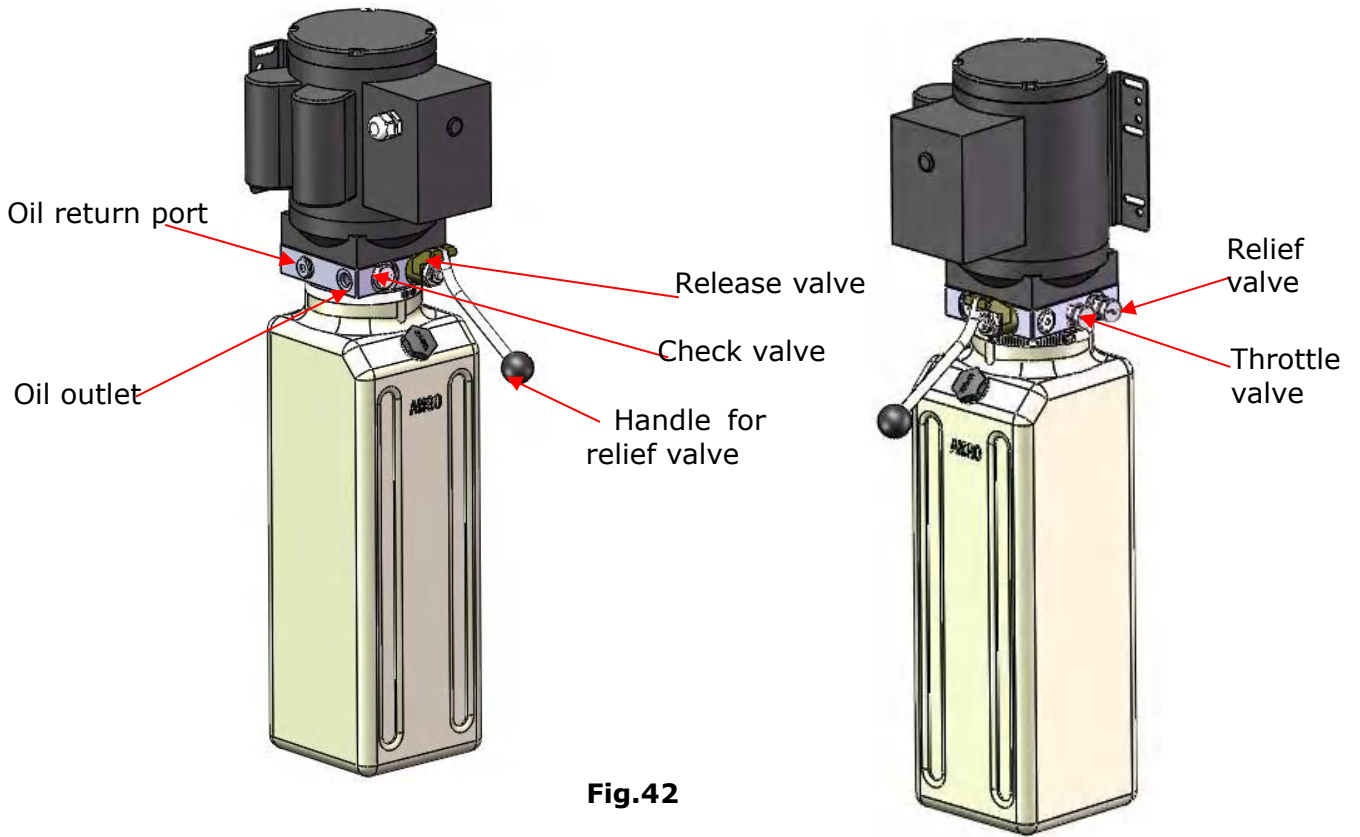


Fig.42

4.3.1 Adjust the lower speed

You can adjust the lower speed of the lift if needing: Turn the Throttle Valve in clockwise direction to decrease the lower speed, or increase the speed in counterclockwise direction.

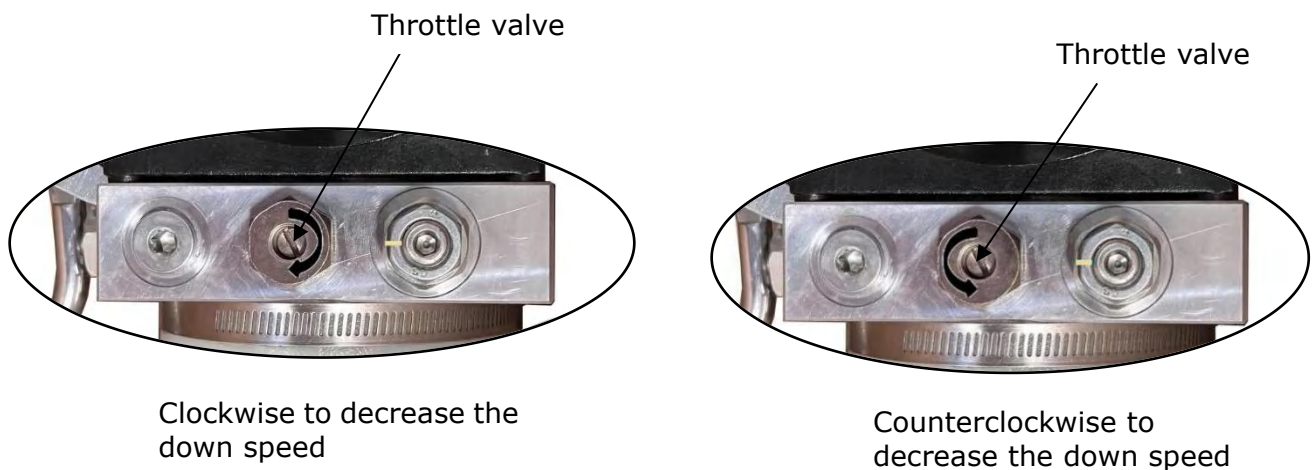


Fig.43

V. TEST RUN

1. Fill the reservoir with approximately 14L Hydraulic Oil (**Note:** In consideration of Power Unit's durability, please use **Hydraulic Oil 46#**).
2. Press the push button , the Cables will be strained. Check whether the Cables match the Pulley. Make sure the Cables are not across.
3. Press the handle of release valve to lock the cross-beam to the safety ladders, and then adjust the platforms to be level by adjusting the nuts of safety ladders.
4. Adjust the cable fitting hex nuts to make platforms and four safety locks work synchronously. You need to run the lift up and down for several times, meanwhile do the synchronous adjustment till the four safety devices can lock and release at the same time.
5. Adjust the clearance between the post and the plastic slider of cross-beam to about 2mm, and then tighten the fixing nut of slider.
6. After finishing the above adjustment, test running the lift with load. Run the lift with Platforms in low position first, make sure the Platforms can rise and lower synchronously and the safety device can lock and release synchronously. And then test run the lift to the top completely. If there are anything improper, repeat the above adjustment.

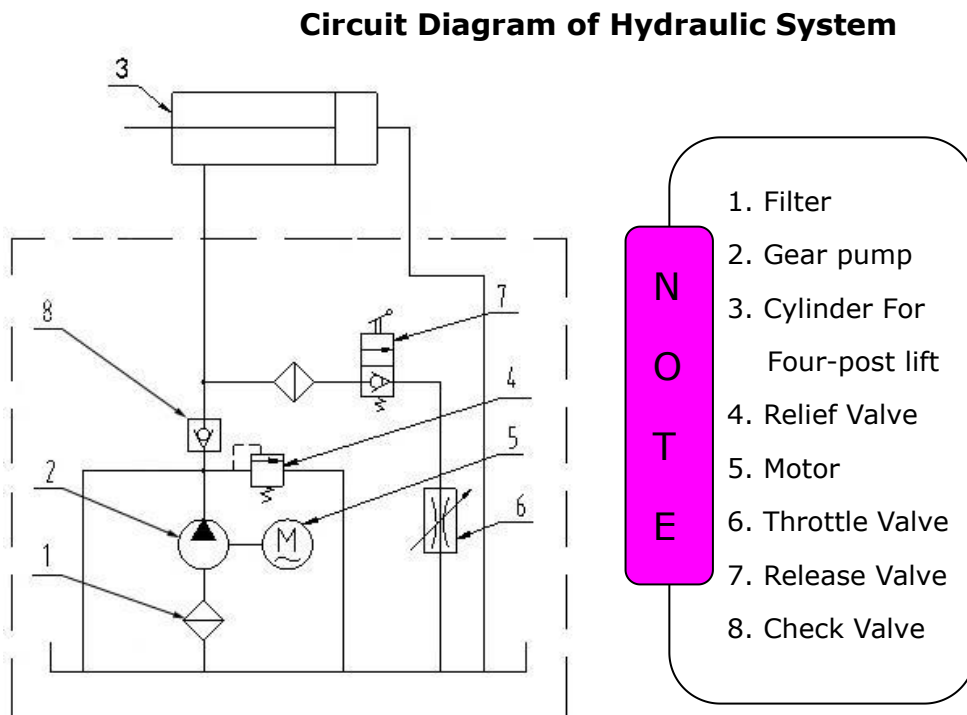


Fig. 44

VI. OPERATION INSTRUCTIONS

To lift vehicle

1. Keep clean of environment near the lift;
2. Ensure the air source switch is activated, drive vehicle to the platform and apply the brake.
3. Turn on the power and press the button **UP**, raise the lift to the working position;
Note: make sure the vehicle is steady when the lift is raised.
4. Press the Handle of release valve to lock the lift in the safety position. Make sure the safety devices are locked at the same height.

⚠️ WARNING It is unsafe to work under the lift without locking at the safety device after it has been lifted up, which may causes vehicle fall, damage, lift damage, human injury or even death.

To lower vehicle

1. Clear obstructions around and under the lift, make sure to move away the people around.;
2. Ensure the air source switch is activated, Press the button **UP**, the lift will be raised for 3-5 seconds, and then press the button of Manual-controlled air valve to release the safety devices, then press the handle of release valve by the other hand then the lift starts being lowered automatically;
3. Drive away the vehicle when the lift is lowered to the lowest position.
4. Turn off the power.

VII. MAINTENANCE SCHEDULE

Monthly:

1. Re-torque the anchor bolts to 150 Nm;
2. Lubricate cable with lubricant;
3. Check all cable connection, bolts and pins to insure proper mounting;
4. Make a visual inspection of all hydraulic hoses/lines for possible wear or leakage;
5. Lubricate all Rollers, Safety devices with 90wt. gear oil or equivalent.
6. Grease the pulley shaft parts for lubrication and maintenance.

Note: All anchor bolts should take full torque. If any of the bolts does not function for any reason, DO NOT use the lift until the bolt has been replaced.


Every six months:

1. Make a visual inspection of all moving parts for possible wear, interference or damage.
2. Check and adjust as necessary, equalizer tension to insure level lifting.
3. Check columns for plumbness.

Oil cylinder maintenance:

In order to extend the service life of the oil cylinder, please operate according to the following requirements.

1. Recommend to use N46 anti-wear hydraulic oil.
2. The hydraulic oil of the lifts should be replaced regularly during using.
Replace the hydraulic oil 3 months after the first installation, Replace the hydraulic oil once a year afterwards.
3. Make at least one full trip raising and lowering per day. For exhausting the air from the system, which could effectively avoid the corrosion of the cylinder and damage to the seals caused by presence of air or water in the system.
4. Protect the outer surface of the oil cylinder's piston rod from bumping and scratching, and timely clean up the debris on the oil cylinder dust-ring and the piston rod.

 **DANGER** Make sure the lift is completed disconnected from the power source before maintenance. If there is any external electrical lock/shutdown device, make sure to implement them before maintenance. The contact with high voltage/current, may cause injury or even death.

VIII. TROUBLE SHOOTING

TROUBLE	CAUSE	REMEDY
Motor does not run	<ol style="list-style-type: none"> 1. Start Button does not work 2. Wiring connections are not in good condition 3. Motor burned out 4. AC contactor burned out 5. Height limit switch is damaged 	<ol style="list-style-type: none"> 1. Replace start button 2. Repair all wiring connections 3. Repair or replace motor 4. Replace AC contactor 5. Replace
Motor runs but the lift is not raised	<ol style="list-style-type: none"> 1. Release valve in damage 2. Gear pump in damage 3. Relief valve or check valve in damage 4. Low oil level 	<ol style="list-style-type: none"> 1. Repair or replace 2. Repair or replace 3. Repair or replace 4. Fill tank
Lift does not stay up	<ol style="list-style-type: none"> 1. Release valve out of work 2. Relief valve or check valve leakage. 3. Cylinder or fittings leaks 	<ol style="list-style-type: none"> 1. Repair or replace 2. Repair or replace 3. Repair cylinder seal or fitting
Lift raises too slow	<ol style="list-style-type: none"> 1. Oil line is jammed 2. Motor running on low voltage 3. Oil mixed with Air 4. Pump leaks 5. Overload lifting 	<ol style="list-style-type: none"> 1. Clean the oil line 2. Check electrical system 3. Fill tank 4. Replace Pump 5. Check load
Lift cannot lower	<ol style="list-style-type: none"> 1. Safety device are in activated 2. Release valve damaged 3. Air Cylinder damaged 4. Air leaks 	<ol style="list-style-type: none"> 1. Release the safeties 2. Replace or repair 3. Replace the cylinder 4. Clean the air line

⚠️ WARNING A lift would be dangerous if operated by inexperienced or distracted operators. Operators should be fully aware that lifting a vehicle is a potentially life-threatening operation, especially if ignoring the mandatory safety precautions.

IX. CAR LIFT SAFETY TIPS

Put this safety tips in a place where you can always alert the operator. Please reference to the lift manufacturer's manual for specific information about the lift.

1. Check the lift daily. If the machine breaks down or has damaged parts, do not operate, and use original equipment parts to repair.
2. **Do not** overload . The rated weight of the manufacturer design is indicated on the label of the lift.
3. Position control of the vehicle and operation of the lift can only be done by a trained and authorized person.
4. **Do not** lift a car with occupants inside. Keep the customers or bystanders away from the lift.
5. Keep the area around the lift free of obstacles, lubricating oil, grease, garbage and other debris for a long time.
6. Carefully drive the vehicle onto the lift and lifting up to the required height for operation. **Noted:** lift it high enough if you are working underneath, and make sure the safety devices are locked.
7. **Noted:** removing(install) parts from(to) a vehicle would cause a sudden shift of gravity which may result in instability of the vehicle. Please refer to the vehicle manufacturer's service manual as a recommended procedure if you need remove/install parts from(to) the vehicle
8. Before lowering the lift , make sure all obstacles underneath, include tool tray, tool rack etc., are all removed.

X. LIFT DISPOSAL:

When the car lift cannot meet the requirements for normal use and needs to be disposed, it should follow local laws and regulations.



Address:

SC Division: 1931 Joe Rogers Jr Blvd, Manning, SC 29102, USA

TX Division: 4310 Adler Dr., Suite #200, Dallas, TX 75211, USA

<http://www.amgohyd.com>

Manual No.: **72246104**
Revision Date: **2026/02**