

SPECIFICATIONS

Model		PRO-12SX	PRO-12ASX
Lifting Capacity		12,000lbs	12,000lbs
Lifting Time		45S	45S
Overall Length(Inc Ramps)	A	232 5/8"	232 5/8"
Overall Length(No Inc. Ramps)	B	190 9/16"	182 11/16"
Overall Width	C	132 1/8"	132 1/8"
Width Between Columns	D	118 1/8"	118 1/8"
Max. Lifting Height	E	74 7/16"	76 3/8"
Max. Lock Height to top of runway		71 1/4"	73 1/4"
Overall Height	F	86"	86"
Minimum Height	G	6 11/16"	8 11/16"
Max. Underneath Height	H	68 7/8"	68 7/8"
Max. Lock Underneath runway		65 3/4"	65 3/4"
Drive-Thru Clearance	I	104 3/16"	104 3/16"
Width Between Runways	J	43 5/16" Min.35 7/16"~ Max.53 3/4"	43 5/16" Min.35 7/16"~ Max.53 3/4"
Outside Edge of Runways	K	83 5/16" Min.75 7/16"~ Max.93 3/4"	83 5/16" Min.75 7/16"~ Max.93 3/4"
Min. Four Wheel Align	L	/	81 3/4"
Max. Four Wheel Align	M	/	159 7/16"
Max. Two Wheel Align	N	/	160 3/4"
Gross Weight		2,229 lbs	2,773 lbs
Motor		2.0HP,220V/60Hz,single phase	

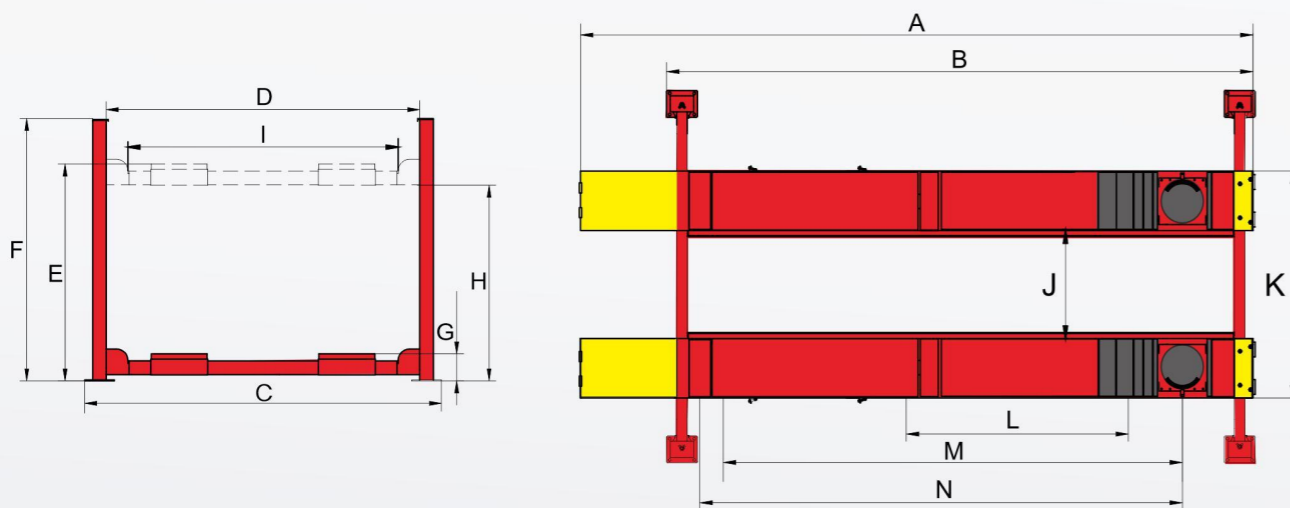

AMGO  **Hydraulics**
The Manufacturing Powerhouse

12,000lbs FOUR POST LIFT

The AMGO PRO-12SX and PRO-12ASX are perfect for everyday general or alignment service with a 12,000lbs capacity. These lifts are wider than 132" and share the advanced features of AMGO's four post lifts, including adjustable, non-slip diamond platforms and double safety locks.



Optional Rolling Jack

RJ-6H: manual hydraulic type 6,000lbs
RJ-6A: pneumatic hydraulic type 6,000lbs

AMGO HYDRAULIC CORPORATION

SC Division: 1931 Joe Rogers Jr Blvd, Manning, SC 29102, USA
Tel:(803)505-6410

TX Division: 4310 Adler, Suite #200, Dallas, TX 75211, USA
Tel:(214)377-8091

AMGO  **Hydraulics**

We're More Than a Manufacturer. We Are the Leader in Innovation, Technology and Service

www.amgohyd.com



PRO-12SX

PRO-12ASX

PRO-12SX

12,000lbs

General service

PRO-12ASX

12,000lbs

Alignment service

- ✓ AMGO ETL certified power unit comes as standard;
- ✓ Mechanical self-locking safety device with air-driven lock release;
- ✓ Extremely wider with over 118" between columns;
- ✓ Primary multiple safety locks and cable-slack protection system come standard;
- ✓ Cable-driven, utilizing aircraft standard high quality cables;
- ✓ Hydraulic cylinder is designed and made to high standard, utilizing high quality oil seals and compensation valve;
- ✓ Non-skid diamond platforms;
- ✓ Stepless adjustable width between platforms;
- ✓ Integrated slip plates and adjustable turnplate pockets (only PRO-12ASX).



Double-safety locks

FEATURES

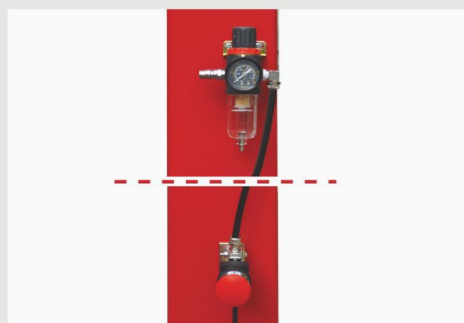

• Oil-water separator and solenoid air valve are installed on the power side column.

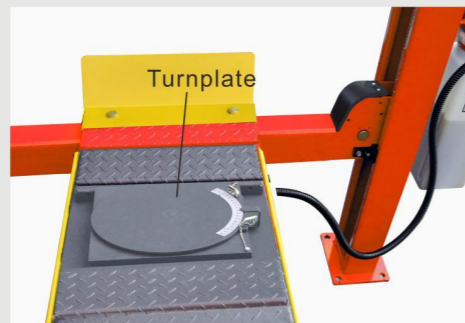

• Adjustable turnplates blocks for the PRO-12ASX. Optional turnplate. Kits No.: 40101



• Stepless adjustable width between platforms.



• Optional Air line kits. Kits No.:40102A



• Optional extension platform adds 26" in length to the platform. Kits No.:40903



• Optional adjustable blocks used with platform extension kit (40903), Kits No.40905