

FOUR POST BOATS & WIDE VEHICLES STORAGE LIFTS

This new series is engineered to revolutionize the way you store your recreational boats and extra-wide vehicles. There are three versatile designs: Standard, Extended Length & Capacity, and Extended Height. Get the perfect fit for any size boat. With two width settings, these lifts feature a large drive-in clearance-over 110" to accommodate various trailers, delivering a storage experience that exceeds expectations.



**408-HPX
409-HPX
408HLX**



Concealed manual single point lock system.



Standard adjustable trailer platform.
Adj. range: 42 3/8"-66 1/4".

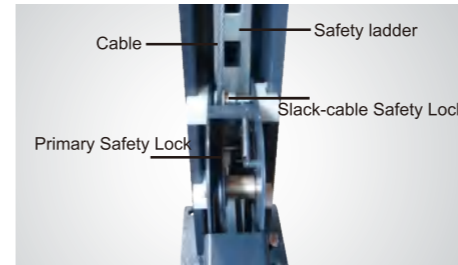

Double safety locks provide additional safety.

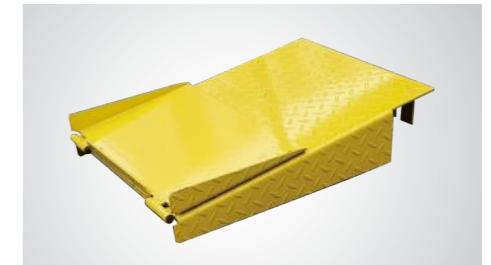

Foldable drive-on ramps.
(each lift 2 units).

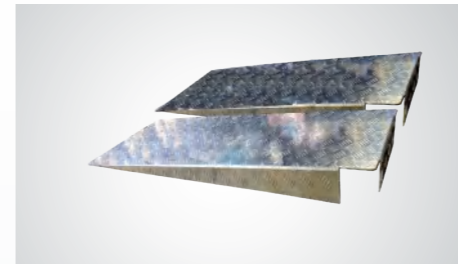

Optional extended aluminum alloy drive-in ramp.
Kits No.: 40815, each lift needs 2 units.



Optional Motor protect cover for outdoor installation with emergency stop switch
Kits No.:40810

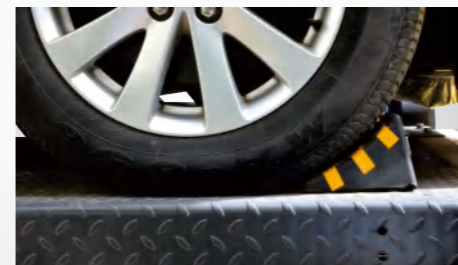

Optional rubber wheel chock.
P/N: 40811.



Optional Trailer Extended Platform adds an extra 24".
Kits No.:40818

AMGO HYDRAULIC CORPORATION

SC Division: 1931 Joe Rogers Jr Blvd, Manning, SC 29102, USA
Tel:(803)505-6410
TX Division: 4310 Adler, Suite 200, Dallas, TX 75211, USA
Tel:(214)377-8091



Standard



Extended Length



Extended Height

MODEL 408-HPX (8,000lbs)

MODEL 409-HPX (9,000lbs)

MODEL 408HLX (8,000lbs)

FEATURES

- Lifting capacity: 8,000lbs (408-HPX & 408HLX), 9,000lbs (409-HPX)
- Concealed manual single point lock system (no air source required)
- Dual safety locks with safety locks and cable-slack protection
- Integrated non-slip diamond platforms
- Flexibility to install power unit at any corner
- Two-width settings so that platforms can accommodate various trailers
- Foldable drive-in ramps come standard
- ETL certified Power unit

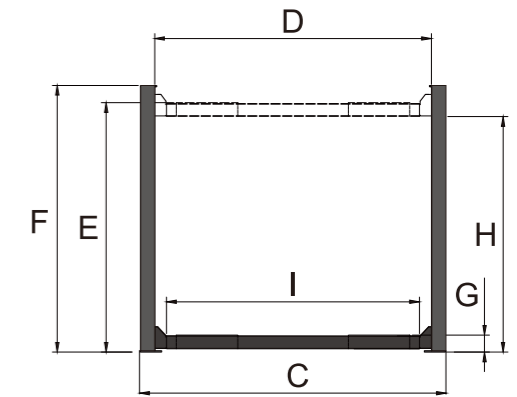
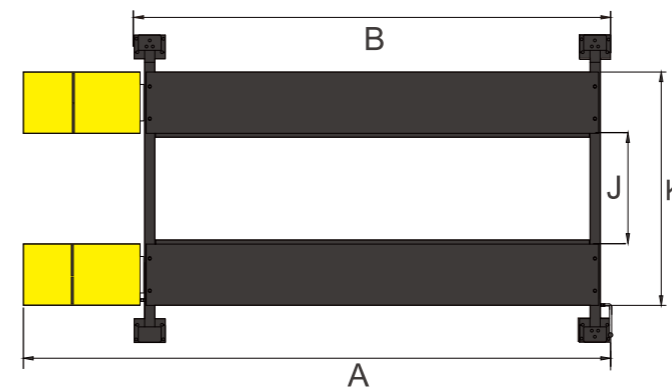

SPECIFICATIONS

Model	Lifting Capacity	Lifting Time	A	B	C	D	E		F	G	H		I	J	K	Gross Weight	Motor Power
			Overall Length (Inc. Ramps)	Overall Length (without Ramps)	Overall Width	Width Between Posts	Max. Lifting Height	Max. locking height	Overall Height	Minimum Height	Max, Underneath Height	Max Lock, Underneath runway	Drive-Thru Clearance	Width Between Runways	Outside Edge of Runways		
408-HPX	8,000lbs	114S	222 1/8"	188 9/16"	131 7/8"	122 3/16"	87 11/16"	84 15/16"	96 5/8"	5 11/16"	82 15/16"	80 3/16"	111"	46 1/2" 66 3/8"	83 7/8" 103 3/4"	1,585lbs	1.0HP, 110V
409-HPX	9,000lbs	174S	238 1/8"	204 11/16"	131 7/8"	122 3/16"	88 1/16"	85 5/16"	96 5/8"	6 1/8"	82 9/16"	79 13/16"	111"	46 1/2" 64 15/16"	86 1/2" 104 15/16"	2,061lbs	1.0HP, 110V
408HLX	8,000lbs	137S	222 1/8"	188 9/16"	131 7/8"	122 3/16"	104 11/16"	101 15/16"	113"	5 11/16"	99 15/16"	97 3/16"	111"	46 1/2" 66 3/8"	83 7/8" 103 3/4"	1,726lbs	1.0HP, 110V



EXCLUSIVE FEATURE
Double-S shape column

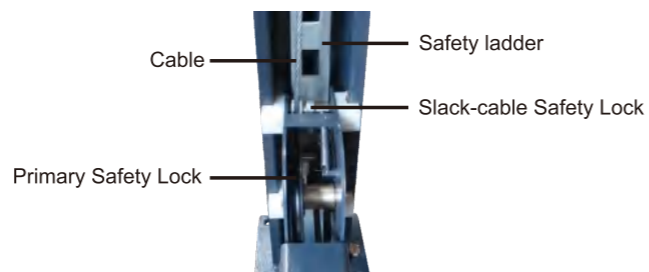

EXCLUSIVE FEATURE
Commercial double safety locks