

TWO POST BASEPLATE LIFT

AMGO BP (base plate) series lifts are built stronger and easier to operate than the any other lifts, with the BP-10 as the standout model. Featuring a 10,000-lb capacity, it handles everything from compact cars to long-wheelbase trucks. Built to professional quality standards, the BP-10 delivers safety, longevity, and reliable operation.



2023/04/07
BP-10

Main Features

- ✓ Lifting capacity: 10,000lbs
- ✓ Commercial-grade with strong structure, designed for professional workshops and home garages
- ✓ 4 symmetric 3-stage telescoping arms accommodate more vehicles
- ✓ Automatic arms restraint
- ✓ Single-point manual safety lock release unlocks both columns from one side
- ✓ Dual safety lock system provides additional safety
- ✓ Self-lubricating UHMW polyethylene sliders
- ✓ Aero sync cables come standard
- ✓ Comes with detachable toe guard and tool tray
- ✓ Standard double-screw rubber pad (pin dia 1/2") with 3" extension adapters



Single-point manual safety lock release unlocks both columns from one side



Two locks, one release. Only available from AMGO.



The optional saddle adapter Kits No.:21108



Standard double-screw rubber pad (pin dia 1/2") with 3" extension adapters

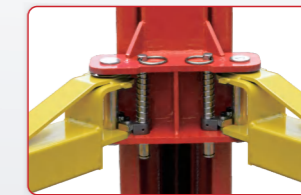

Automatic arm restraints with release

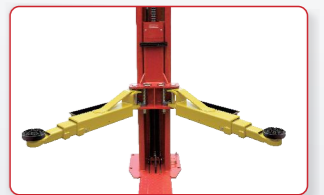

Symmetric 4 three-stage telescoping arms accommodate more vehicles

SPECIFICATIONS

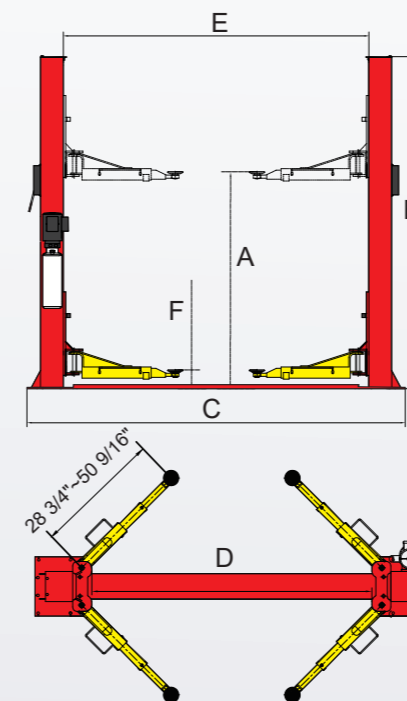

Model	BP-10
Lifting Capacity	10,000 lbs
Lifting Time	62s
Max. Lifting height: (w/o extension adapter)	A 76 9/16"~78 7/16"
Max. Lifting height: (w/ extension adapter)	
Max. lock height: (w/o extension adapter)	
Max. lock height: (w/ extension adapter)	
Overall Height	B 111 7/8"
Overall Width	C 139 1/8"
Drive-Thru Clearance	D 100 13/16"
Width Between Columns	E 112 1/4"
Minimum Pad Height	F 3 3/4"
Gross Weight	1,697 lbs
Motor	2.0HP, 220V 60Hz, single phase

AMGO HYDRAULIC CORPORATION

SC Division: 1931 Joe Rogers Jr Blvd, Manning, SC 29102, USA
Tel:(803)505-6410

TX Division: 4310 Adler, Suite 200, Dallas, TX 75211, USA
Tel:(214)377-8091