

Installation And Service Manual

FOUR POST PARKING LIFT Model: 408-HPX

Cargo Claims

If there is any missing or damaged product during transportation, the buyer must notate on the shipping paperwork or refuse the shipment. NOTATE ALL DAMAGE OR REFUSE DAMAGED SHIPMENT!



DANGER

Read the entire contents of this manual before using this product. Failure to follow instructions and safety precautions could result in serious injury or even death. Make sure all other operators also read this manual. Keep this manual near the machine so that it can be seen by all users. By proceeding with installation and operation, you agree that you are fully understand the contents of this manual and take full responsibility for the use of the product.

CONTENTS

PROFILE.....	1
IMPORTANT SAFETY INSTRUCTIONS.....	3
I. PRODUCT FEATURES AND SPECIFICATIONS.....	5
II. STORAGE AND INSTALLATION REQUIREMENT.....	7
III. INSTALLATION STEPS.....	9
IV. EXPLODED VIEW.....	30
V. TEST RUN.....	36
VI. OPERATION INSTRUCTIONS.....	38
VII. MAINTENANCE SCHEDULE.....	39
VIII. TROUBLE SHOOTING.....	40
IX. CAR LIFT SAFETY TIPS	41
X. LIFT DISPOSAL	41

Explanation of the safety warning symbols used in this manual

 DANGER	Risk of death or injury
 WARNING	Dangerous or unsafe practices that may result in death or injury
 CAUTION	Dangerous or unsafe practices that may result in personal injury, product damage or property damage
ATTENTION	Conditions that may result in damage to products or property

PROFILE

This installation and service manual is specially prepared for you. Your new lift is the product of over a decade of continuous research, testing and development and is the most technologically advanced lift on the market today.

Please make sure to read through this manual before operating the lift.

Record the information on the nameplate label here:

Model No.: _____

Serial No.: _____

Manufacturer date: _____

WARRANTY

The warranty period for the steel structure part of new car lift is 5 years, hydraulic components, bronze bushings, slider blocks and plastic parts are under warranty for 2 years, electrical components and cables warranty for 1 year. Rubber pads are without warranty. During the warranty period, the manufacturer will repair or replace the defective parts free of charge including shipping costs.

This warranty does not cover damage caused by normal wear and tear, improper use, damage in transit, or damage caused by lack of maintenance.

This warranty is unique and supersedes what is expressed and implied in all other warranties. The manufacturer shall not be liable for any particular, indirect or accidental damage resulting in breach of or delay in the execution of the warranty. The manufacturer reserves the right to design and improve the product and has no obligation to make notice of the changes in advance.

The product warranty based on the above clause is based on the model number and serial number of the equipment. This information must be provided in conjunction with all warranty information at the time of service and warranty.

SAFETY WARNING LABEL



Fig.1

IMPORTANT SAFETY INSTRUCTIONS

In order to properly maintain your product and ensure operator safety, it is the responsibility of the product owner to read and follow these instructions!

1. Ensure product installation full complies with all applicable local and national rules, ordinances and regulations;
2. Ensure that all operators are properly trained, know how to operate the unit safely, and are properly supervised;
3. Do not operate the lift until you are sure all parts are in place and operating correctly;
4. Keep your hands and feet away from the machine. Keep hands and feet away from any moving parts. Keep your feet away from the lift as it descends and avoid pressing on pointed objects;
5. Keep the work area clean. A cluttered workspace can lead to injuries;
6. The machine is only approved for indoor installation and use. Outdoor installation is prohibited;
7. Only trained operators are allowed to handle the lift machine. All untrained persons must stay away from the workplace. Never allow untrained persons to handle or operate the machine;
8. Use the lift properly. Use the lift in the correct way;
9. Warning! Keep persons and objects from the lift when lifting the a vehicle;
10. If the vehicle is at risk of falling, make sure no one is around the lift;
11. Before preparing to approach or service the vehicle, ensure that the safety device is in effect;
12. Dress appropriately when operating machines, and consider wearing non-slip steel-toe shoes for safety;
13. Beware of electric shock. In order to protect the operator from electric shock, the lift in use must be grounded. Do not connect the green wire to the terminal. This is the ground wire;
14. Danger! The power supply used in this type of lift has high voltage. Please disconnect the power supply before any circuit repair. Unplug in case the power supply is accidentally switched on during maintenance;
15. Warning! There is a risk of explosion. There are parts in the equipment that produce arc light and spark. Do not operate near flammable gas. This machine should not be placed in the lounge or basement;
16. Maintain with care. Keep the machine clean for better and safer operation. Perform

proper lubrication and maintenance procedures according to the manual. Keep handles or buttons clean, dry, and free of oil;

17. Stay alert. Use common sense to observe what you are doing and stay alert;
18. Check for damaged parts. Check for adjustments to moving parts, damage to parts, or anything that may affect their operation. Do not use the machine if the parts are damaged;
19. Do not remove relevant safety parts from the machine. Do not use a lift if it is damaged or missing;
20. Operate the lift only at temperature between 5°C to 40°C (41°F to 104°F).

 **DANGER** Be very careful when installing, operating, maintaining or repairing this equipment. Failure to comply may result in property damage, product damage, injury or (in very rare cases) death. Ensure that only authorized personnel operate the equipment. All repairs must be carried out by an authorized technician. Do not modify the machine, this voids the warranty and increases the probability of personal injury or property damage. Ensure to read and follow this instructions on the label.

I. PRODUCT FEATURES AND SPECIFICATIONS

408-HPX FEATURES

- Single-cylinder drive and cable transmission.
- Single-point manual safety release enhances the convenience and reliability of descent operations.
- Both automatic mechanical primary safety device and cable-slack secondary safety device are equipped for enhanced security.
- Optional: Rolling jacks, caster kits
- Non-skid diamond platforms and adjustable safety lock ladders.

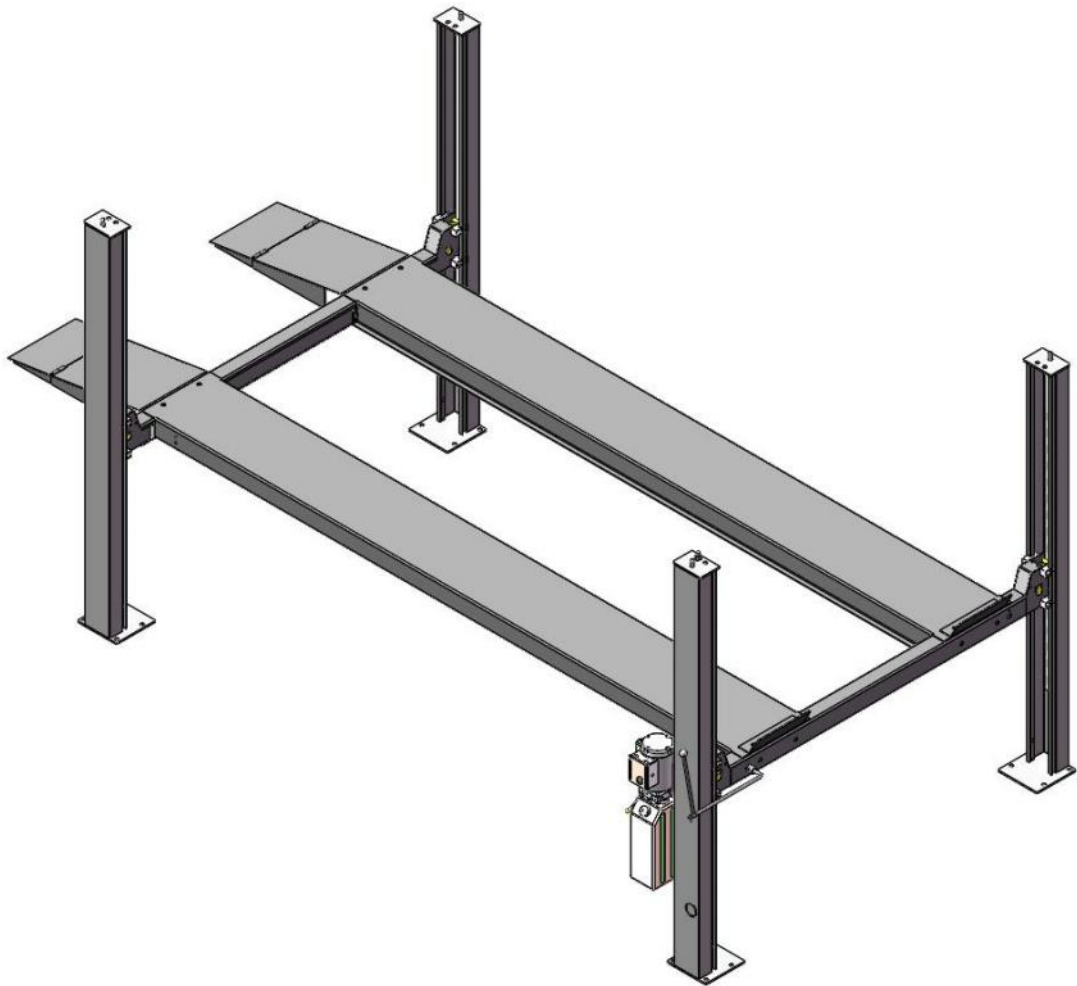

Fig. 2

Dimension

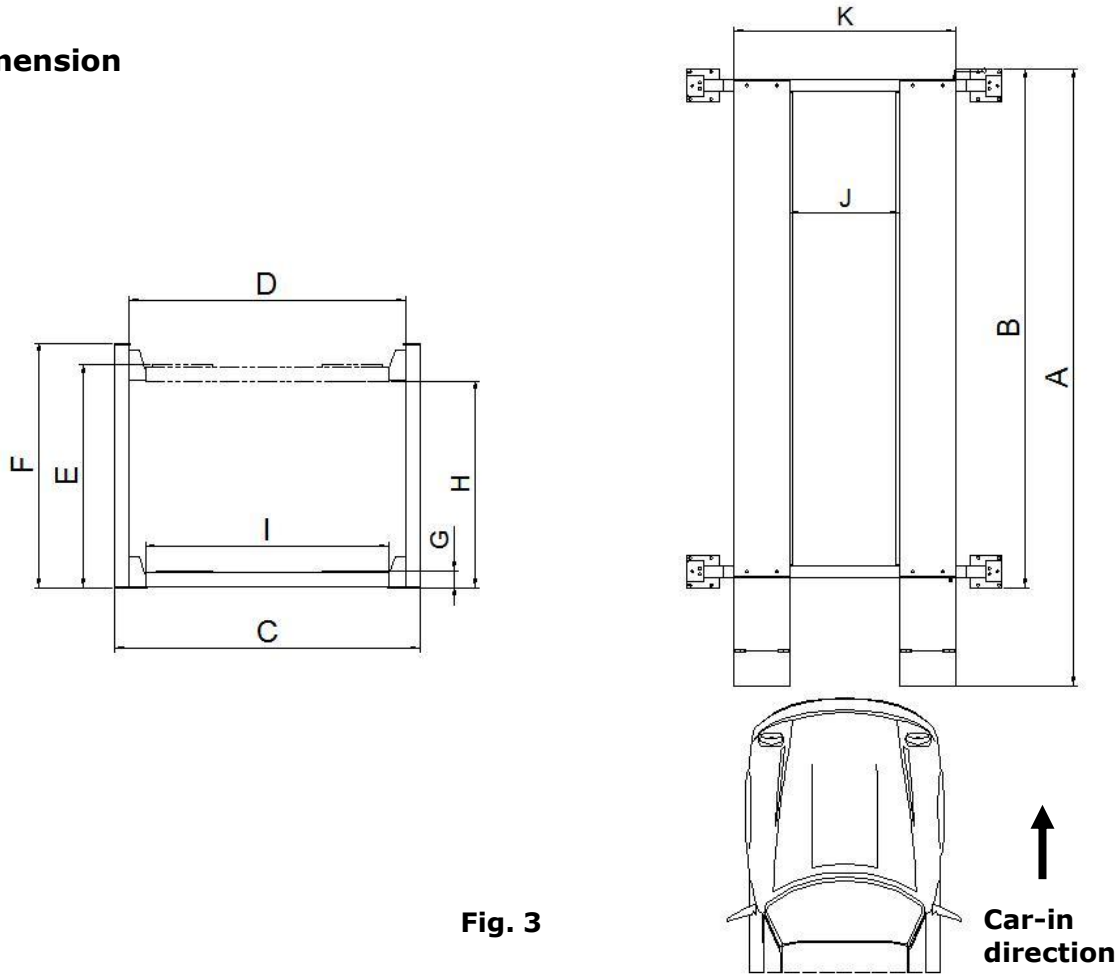

Fig. 3

SPECIFICATION

Model	Lifting Capacity	Lifting Time	A	B	C	D	E		F
			Overall Length (Inc. Ramps)	Overall Length (Without Ramps)	Overall width	Width between posts	Max. Lifting Height	Max. Locking height	Overall height
408-HPX	8000lbs	114s	222 1/8"	188 9/16"	131 7/8"	122 3/16"	87 11/16"	84 15/16"	96 5/8"

G	H		I	J		K		Motor
Min. height	Max. height underneath runway	Max. Locking height underneath runway	Drive Through Width	Width between runway		Outside edge of runways		
				Wide	Narrow	Wide	Narrow	
5 11/16"	82 15/16"	80 3/16"	111"	46 1/2"	66 3/8"	83 7/8"	103 3/4")	1.0HP, 110V/60Hz

⚠Warning When driving the vehicle into the lift, make sure it is positioned in middle of either group of runways. Any hit of the lift could result in damage to either the vehicle or lift.

II. INSTALLATION REQUIREMENT

A. TOOLS REQUIRED

✓Rotary Hammer Drill (Φ19)



✓Hammer



✓Level Bar



✓Adjustable Spanner (12")



✓Wrench set

(10#, 13#, 14#, 15#, 17#, 19#, 24#, 27#, 30#,))



✓Ratchet Spanner With Socket (28#)



✓Carpenter's Chalk



✓ Screw Sets



✓ Tape Measure (7.5m)



✓Pliers



✓ Lock wrench



✓ Socket Head Wrench (3#, 5#, 8#)



Fig. 4

B. Equipment storage and installation requirements.

- 1 . Store the equipment in a dry, non-moldy, non-flammable environment.
- 2 . The lift is generally approved for indoor installation and use. If need outdoor installation, the optional motor protect cover is required. (Kits No.: 40810)
- 3 . When installing the device, take safety precautions according to the instructions to avoid device damage.
- 4 . During installation, all parts should be fastened to ensure the stability and smooth operation of the machine.
- 5 . After installation, the whole machine should be checked to make sure that every component is working properly.

C. The equipment should be unloaded and transferred by forklift.

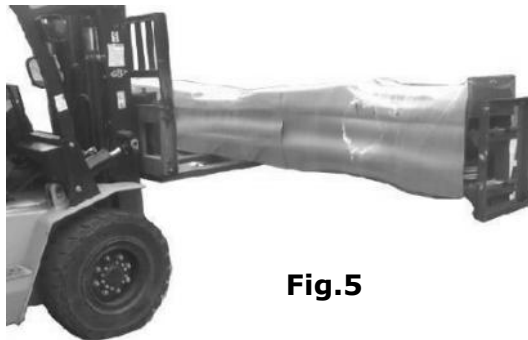

Fig.5

D. SPECIFICATIONS OF CONCRETE (See Fig. 6)

Specifications of concrete must be adhered to the specification as following.

Failure to do so may result in lift and/or vehicle falling.

1. Concrete must be thickness 100mm minimum and without reinforcing steel bars, and must be dried completely before the installation.
2. Concrete must be in good condition and must be of test strength 3000psi (210kg/cm²) minimum. Solidify at least 15 days.
3. Floors must be level and no cracks.

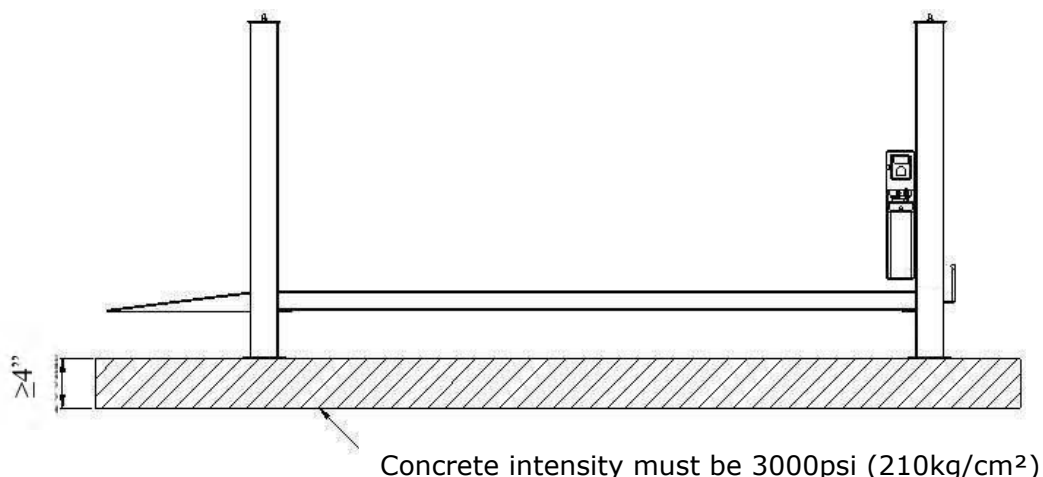



Fig. 6

E. POWER SUPPLY

1. You are required to use a licensed and qualified electrician for the installation process.
2. The power supply capacity must be more than 3.0HP, with a cord larger than 12AWG, and must be properly grounded.

 **DANGER** All electrical wiring must be performed by a licensed and certified electrician. Attempting to connect the circuit without proper certification may result in damage to the lift or electrocution, resulting in serious injury or death.

III. INSTALLATION STEPS

A. Location of installation

1. Installation space: Ensure there is enough space for the lift. Accurately measure the front, back, side and top mounting dimensions and refer to the below figure data .
2. Overhead obstacle: Check for overhead obstacles, such as building supports, heaters, lights, wires, and low ceilings, etc..
3. Installation: The lift is only approved for indoor installation and use, and outdoor installation is prohibited.
4. Floor: Install lift only on flat concrete floor. Do not install on asphalt or any other surface.

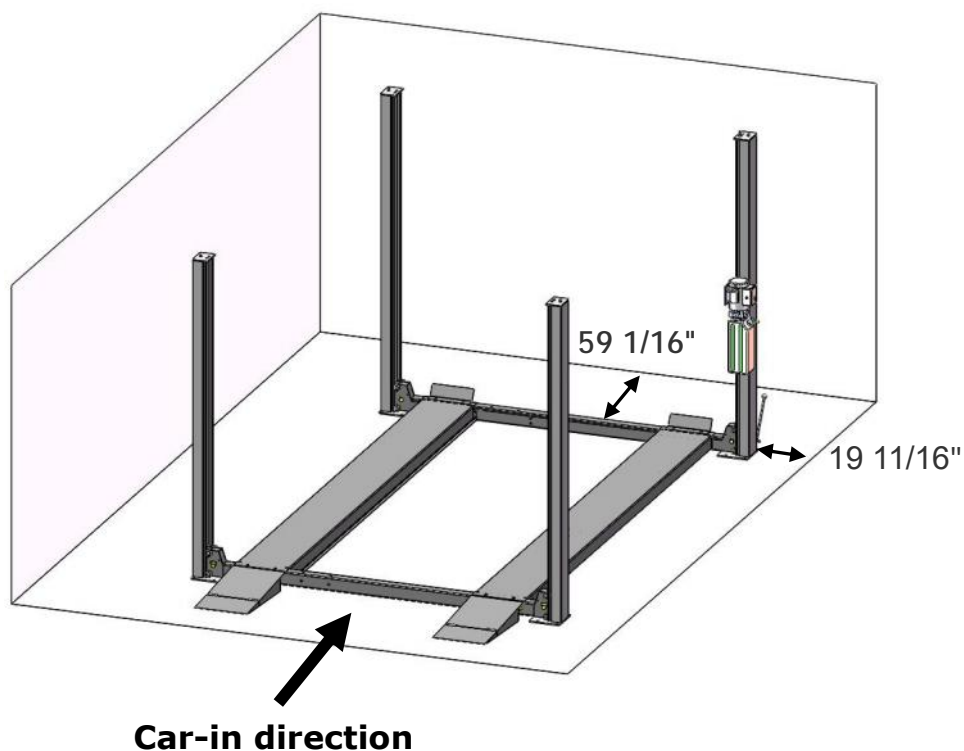

Fig. 7

⚠ CAUTION If installing the lift on a surface with slopes more than 3°, it could lead the operator to injury or even death. This lift is designed for installation on a flat and level surface only. (Defined as no more than 10mm difference over the installation area). If the floor cannot be leveled, consider changing installation locations.

B. Check the parts before assembly.

1. Packaged lift and hydraulic power unit (See Fig. 8).



Fig. 8

2. Move the lift aside with a fork lift or hoist, open the package and check the parts according the shipment list. (See Fig. 9).

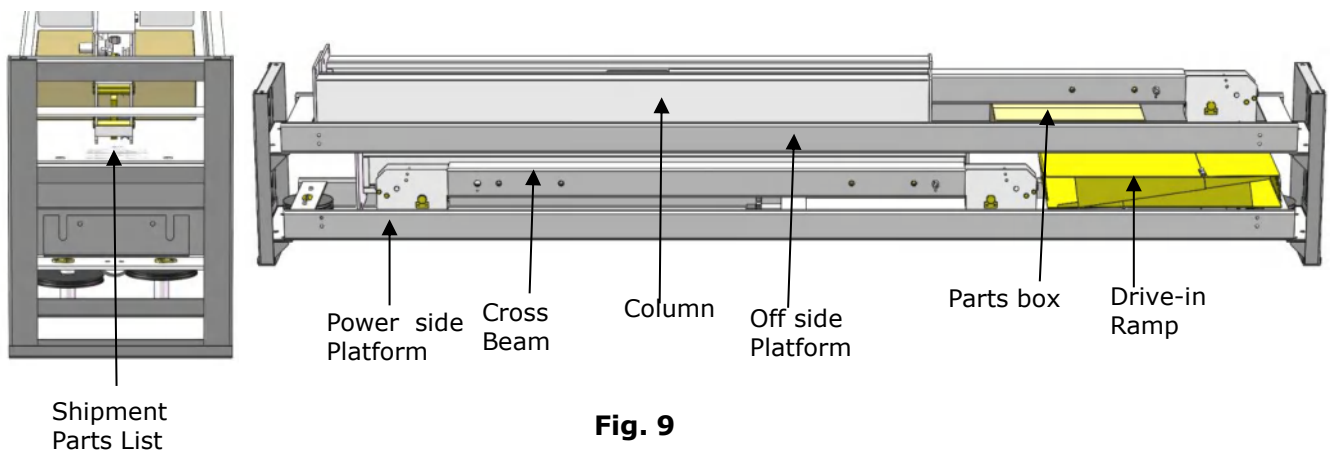

Fig. 9

3. Move the columns and cross beams aside to the installation position. (see Fig 10)

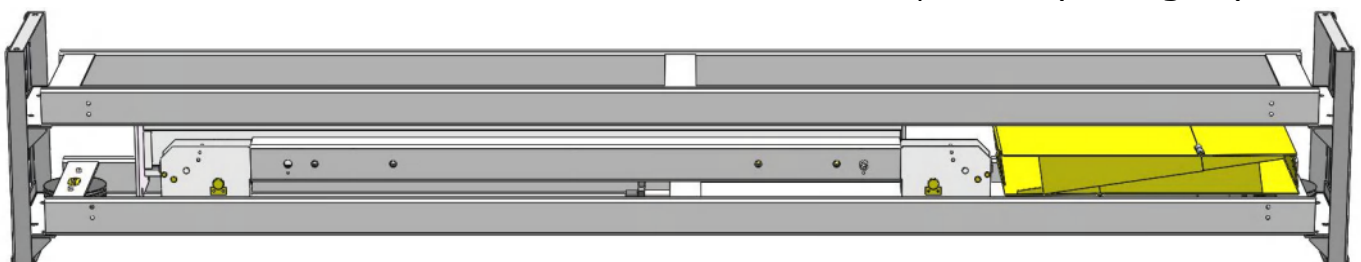

Fig. 10

4. Loose the screws of the upper package stand, take off the off side platform, take out the parts inside the power side platform, then remove the package stand.
5. Move aside all the parts to the installation position and check the parts according to the parts list **(See Fig. 11)**.

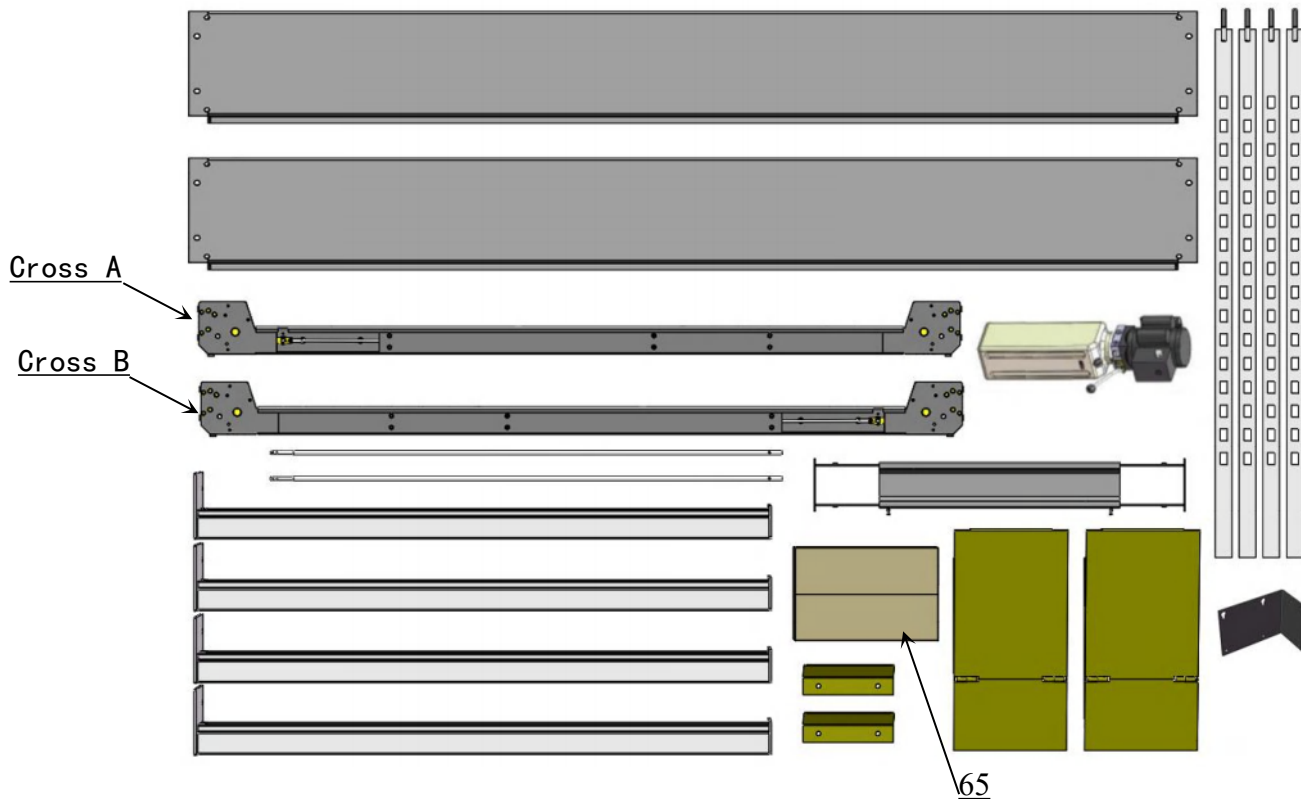

Fig. 11

6. Check the parts of parts box according to the parts box lift . **(See Fig. 12)**.



Fig. 12

7. Check the parts of the parts bag according to the parts bag list (See Fig. 13).

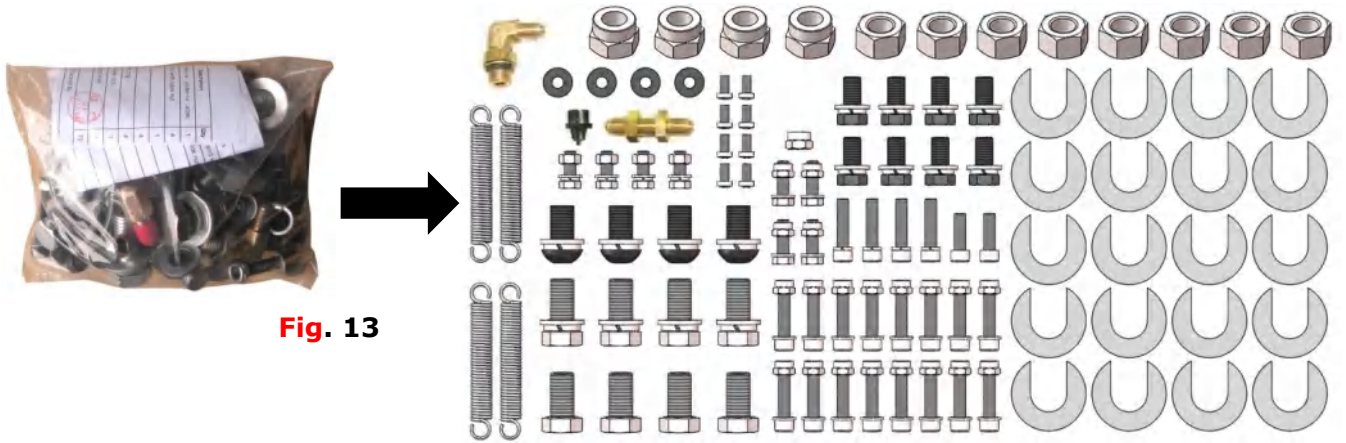

Fig. 13

C. Use a carpenter’s chalk line to establish installation layout (see Fig 14) .

Place the posts according to the installation dimension.

Note: Reserve space front and behind the installation site.

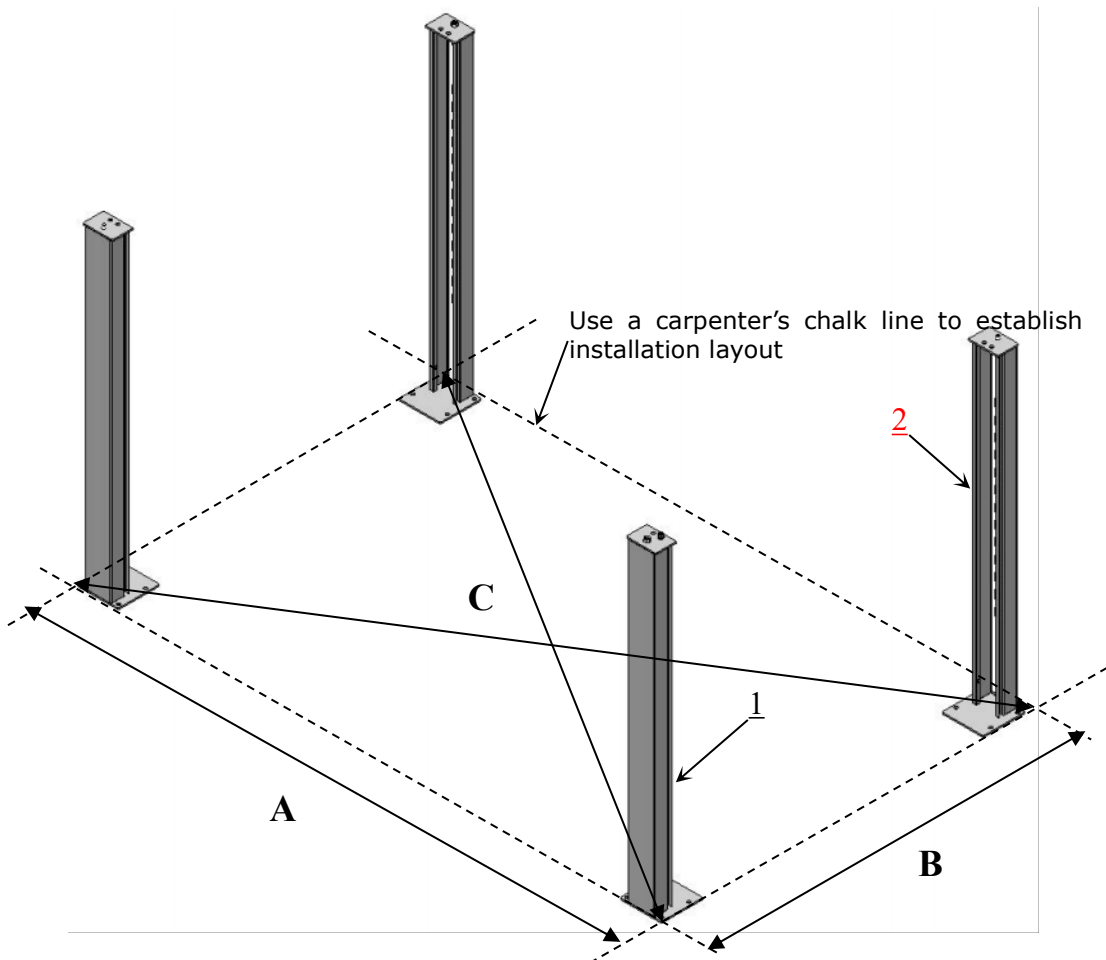

Fig.14

MODEL	A	B	C
408-HPXX	188 9/16" (4790mm)	131 7/8" (3350mm)	230 1/8" (5845mm)

D. Install cross beams (See Fig.15, Fig.16).

Make sure the rotation device of cross beam is close to the power side column (include 4- ϕ 10 holes).

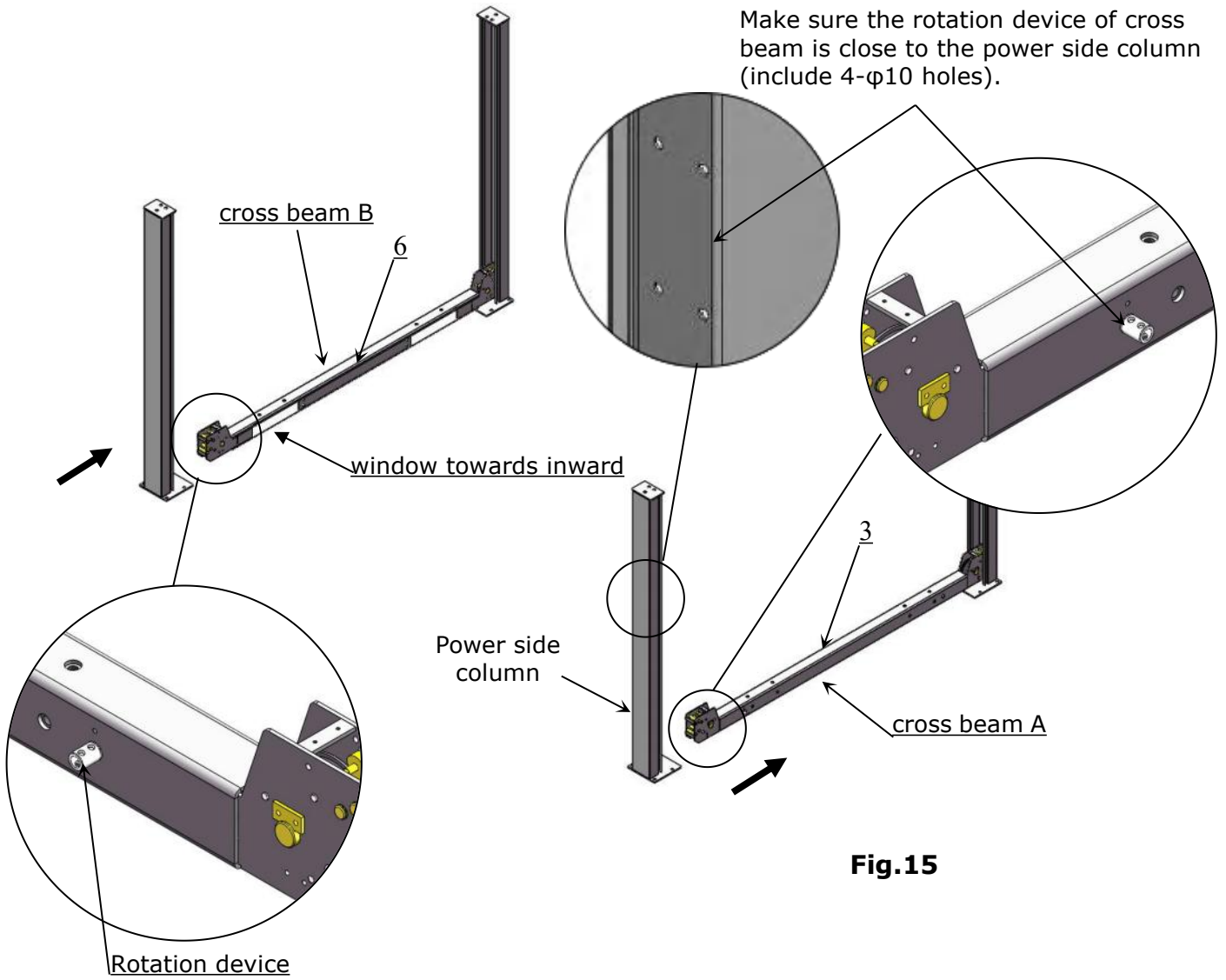

Fig.15

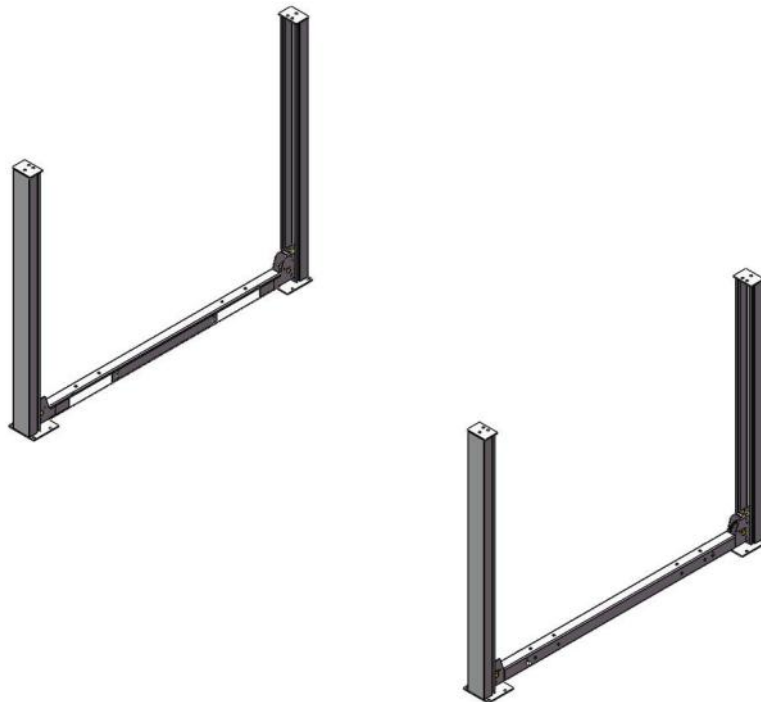

Fig.16

E. Install the Safety ladders.

1. Adjust the nuts of the four safety ladders to the same position, and then install the safety ladders(See Fig. 17.)

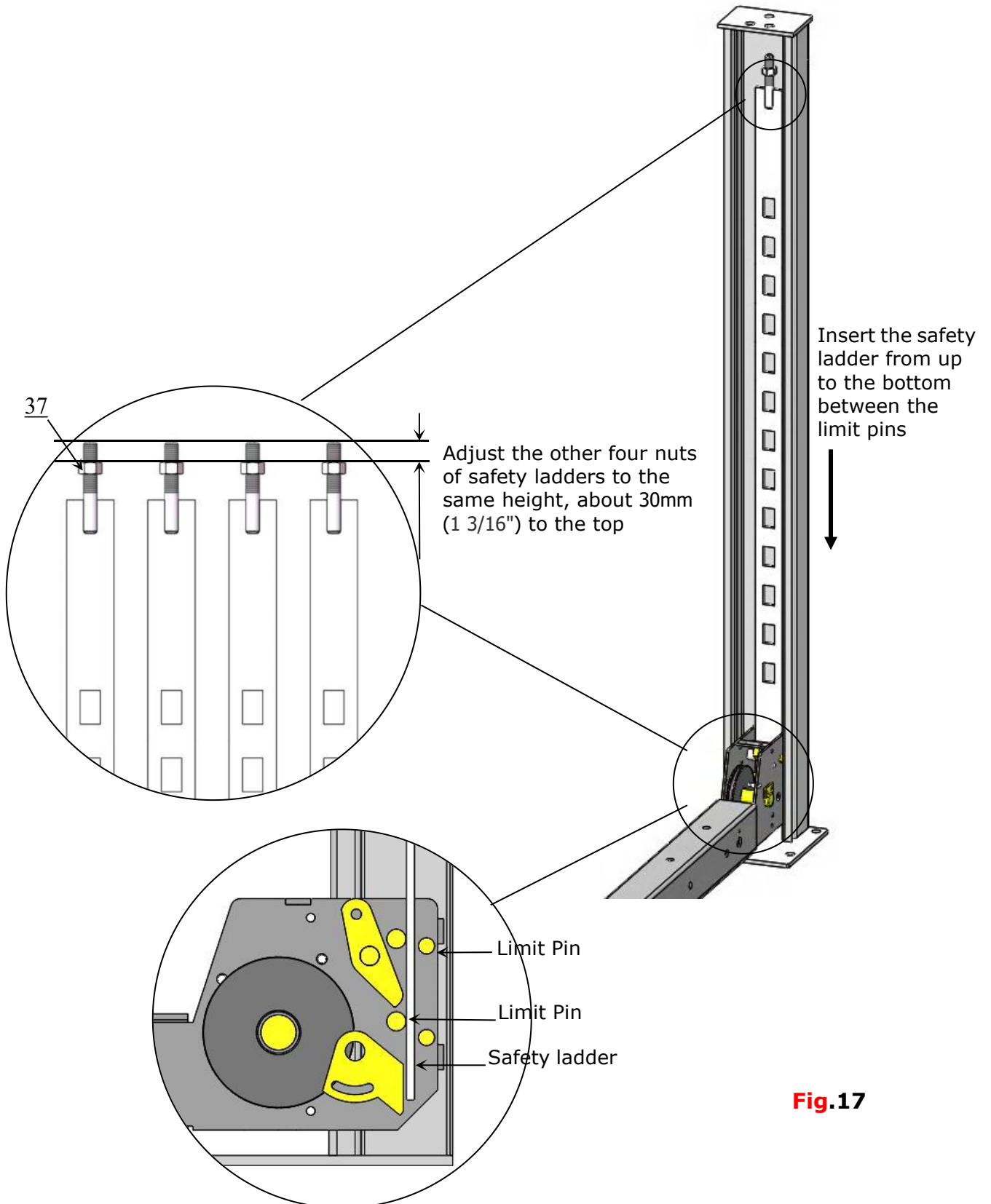
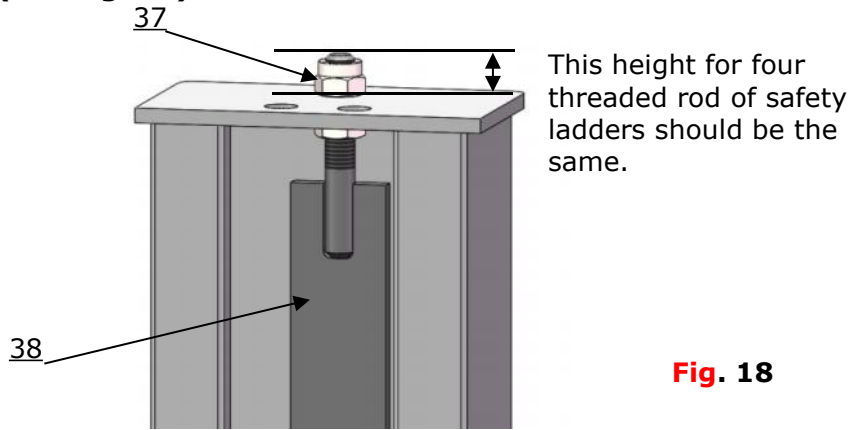

Fig.17

Safety ladder is inserted between limit pins of the cross beam

2. Install safety ladders (See Fig. 18).



Safety ladder pass through the hole of the top plate and the self-locking nut is screwed on. The upper and lower nuts do not need to be tightened.

F. Put the cross beams at the same height and lock on the safety ladders (See Fig. 19).

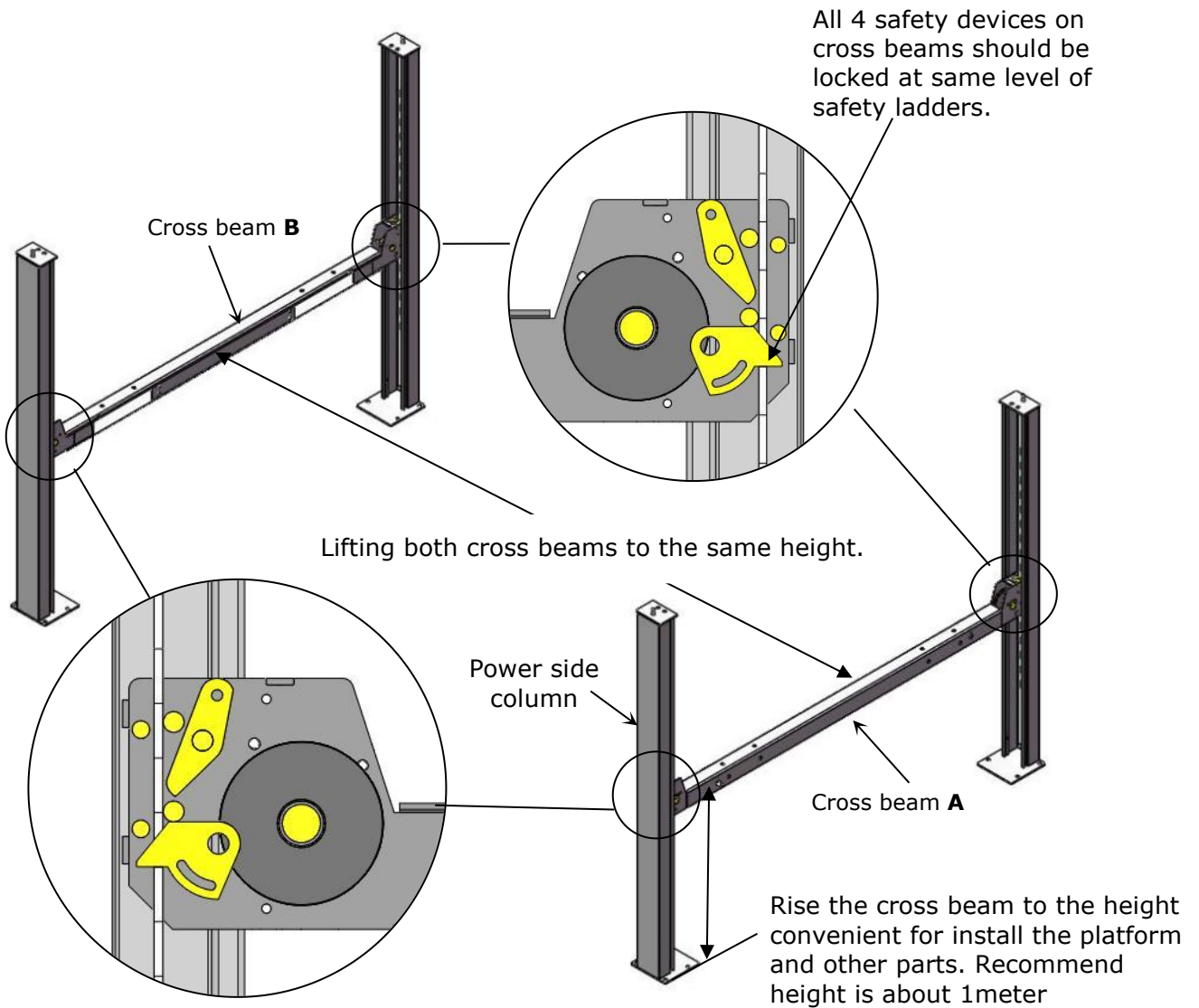

Fig. 19

G. Install power side platform.

1. Install the power side platform on the cross beams by a forklift or manually, offset the cross beams leaning outward until the pulleys of both platforms can enter into the cross beam windows (See Fig.20), align holes on the power side platform and cross beam, then screw up the bolts.

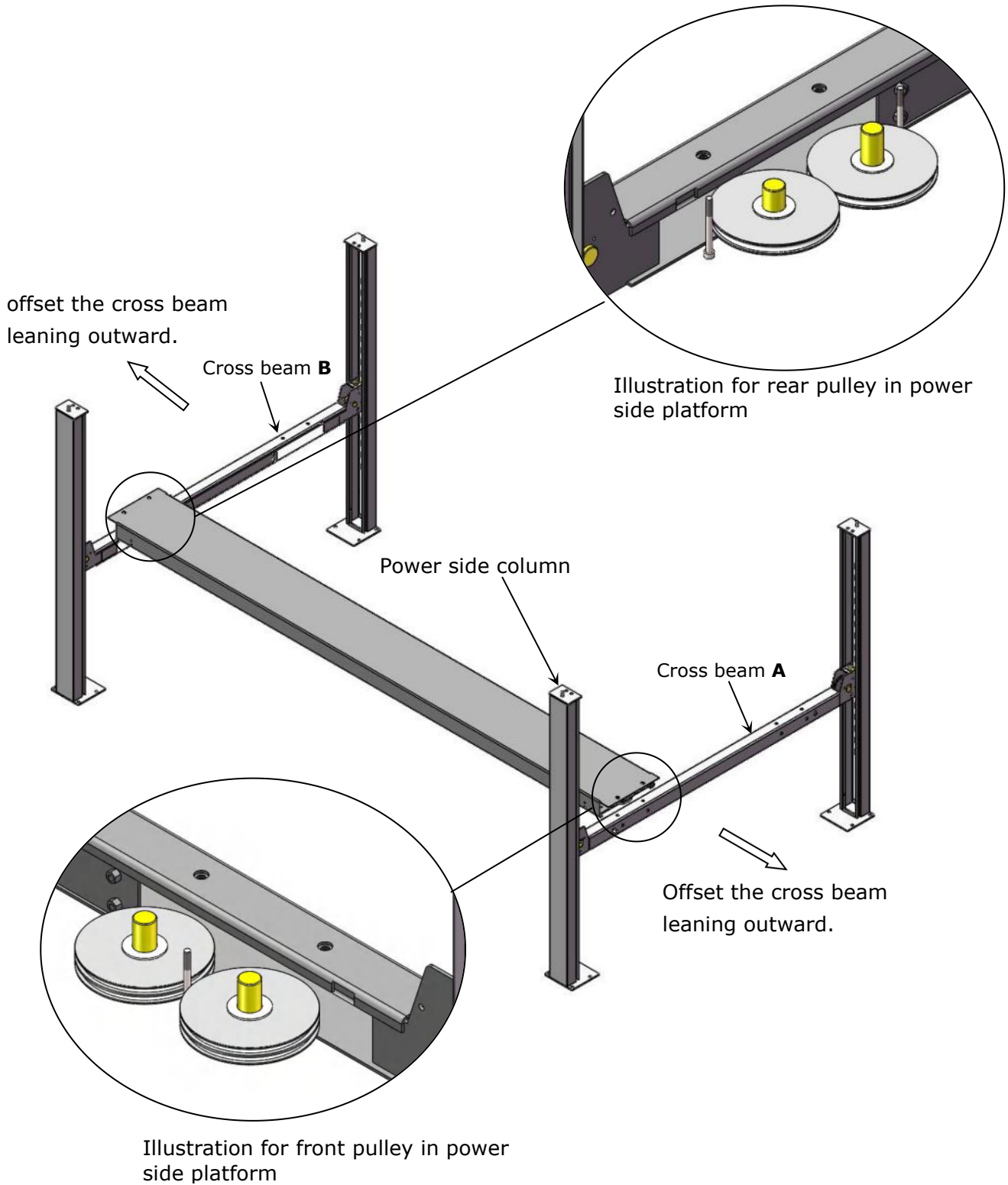

Fig. 20

2. Install connecting bolts of tire stop and platforms: Tighten cross beam B and platform with round head socket bolts, tighten cross beam A, platform and tire stop plate with hex bolts. (Note: Tire stop plate should be installed at the front direction. Hex bolts are used for tire stop plate, and the round head socket bolts are for the other side), See Fig.21

Notice: The lift is designed for drive-in from either direction of cross beams. The diagram below shows the drive-in direction from cross beam B. If driving in from cross beam A direction, make sure the tire stop plate is installed on cross beam B with hex bolt. Install the power unit accordingly and place the control handle on the same side as the power unit.

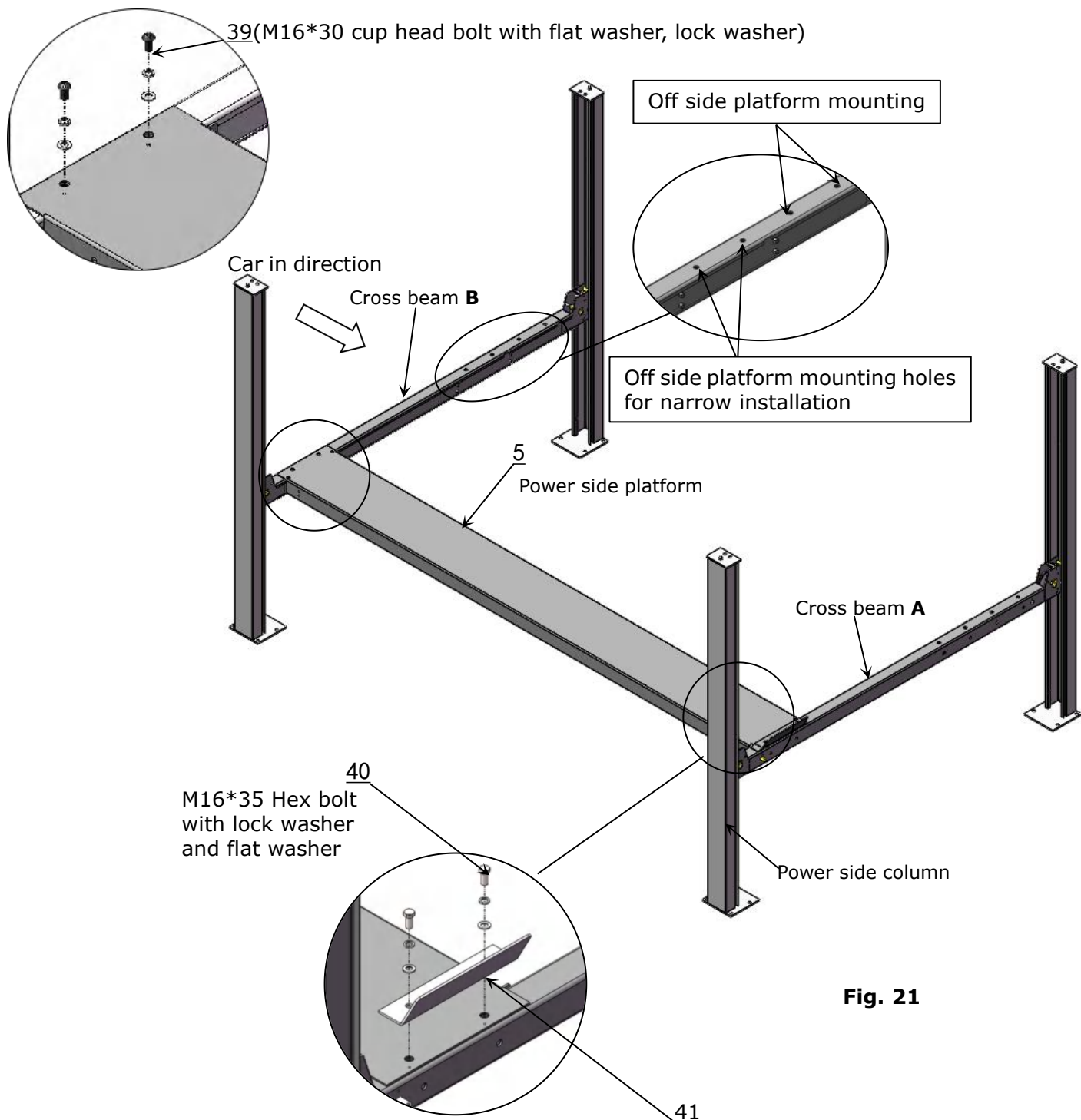
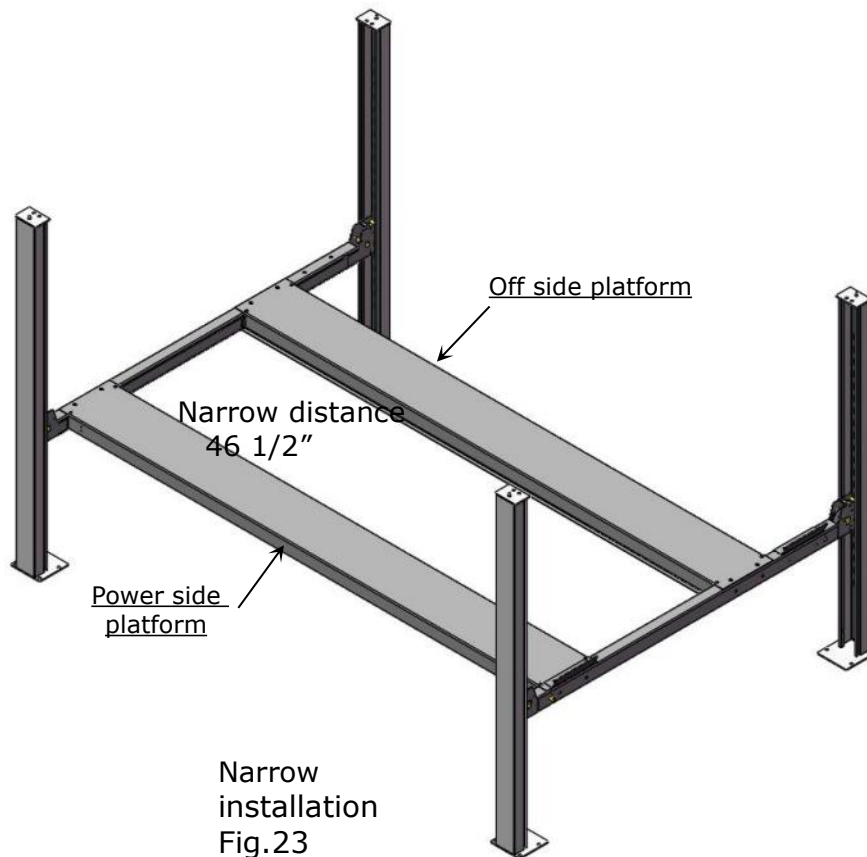
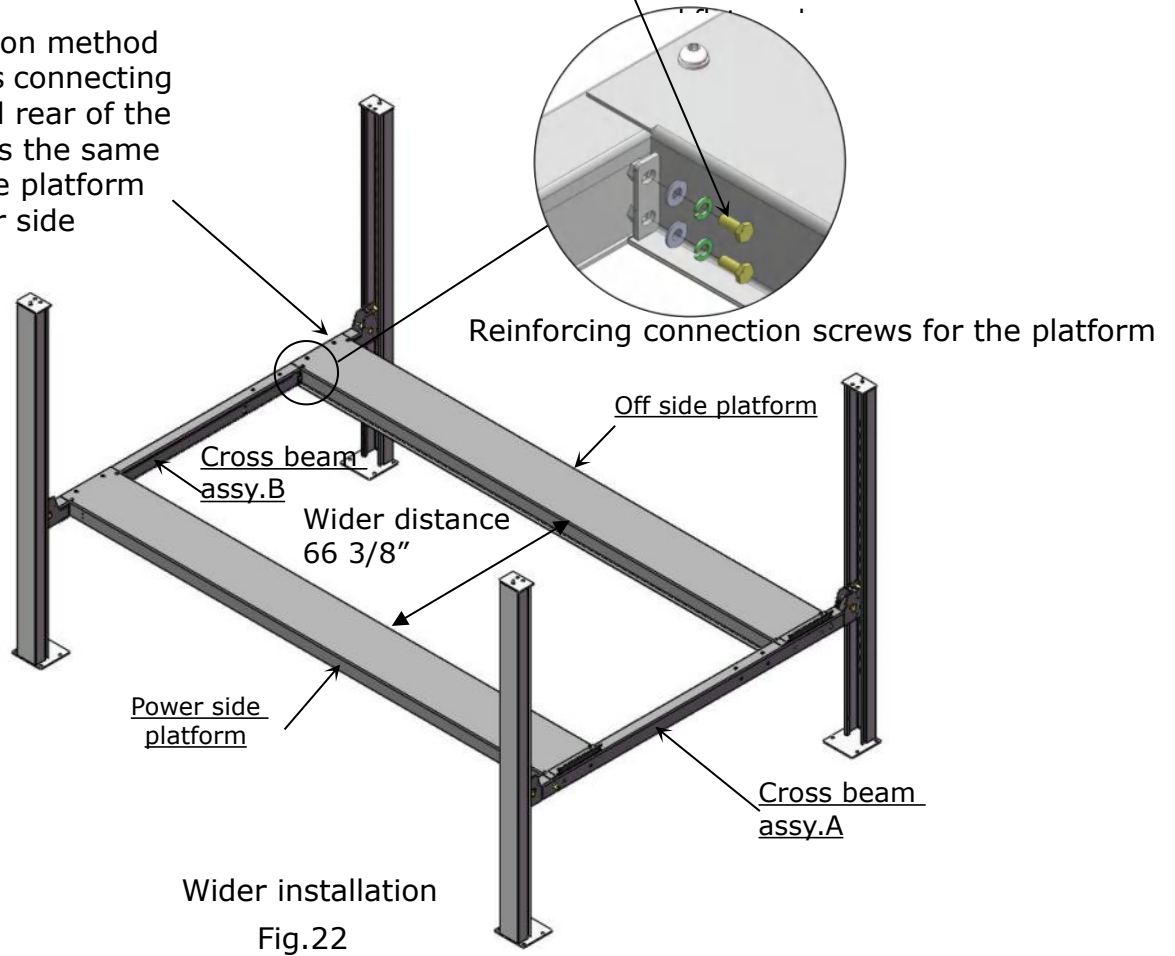

Fig. 21

3. In the same way, place the off side platform on cross beams, align the holes and tighten with bolts. Fig 22 for wider installation, Fig 23 for narrow installation.

The installation method of the screws connecting the front and rear of the platform is as the same as that of the platform on the power side

42 M12*20 Hex bolt with lock washer



H. Install offside platform and limit slider (See Fig. 24).

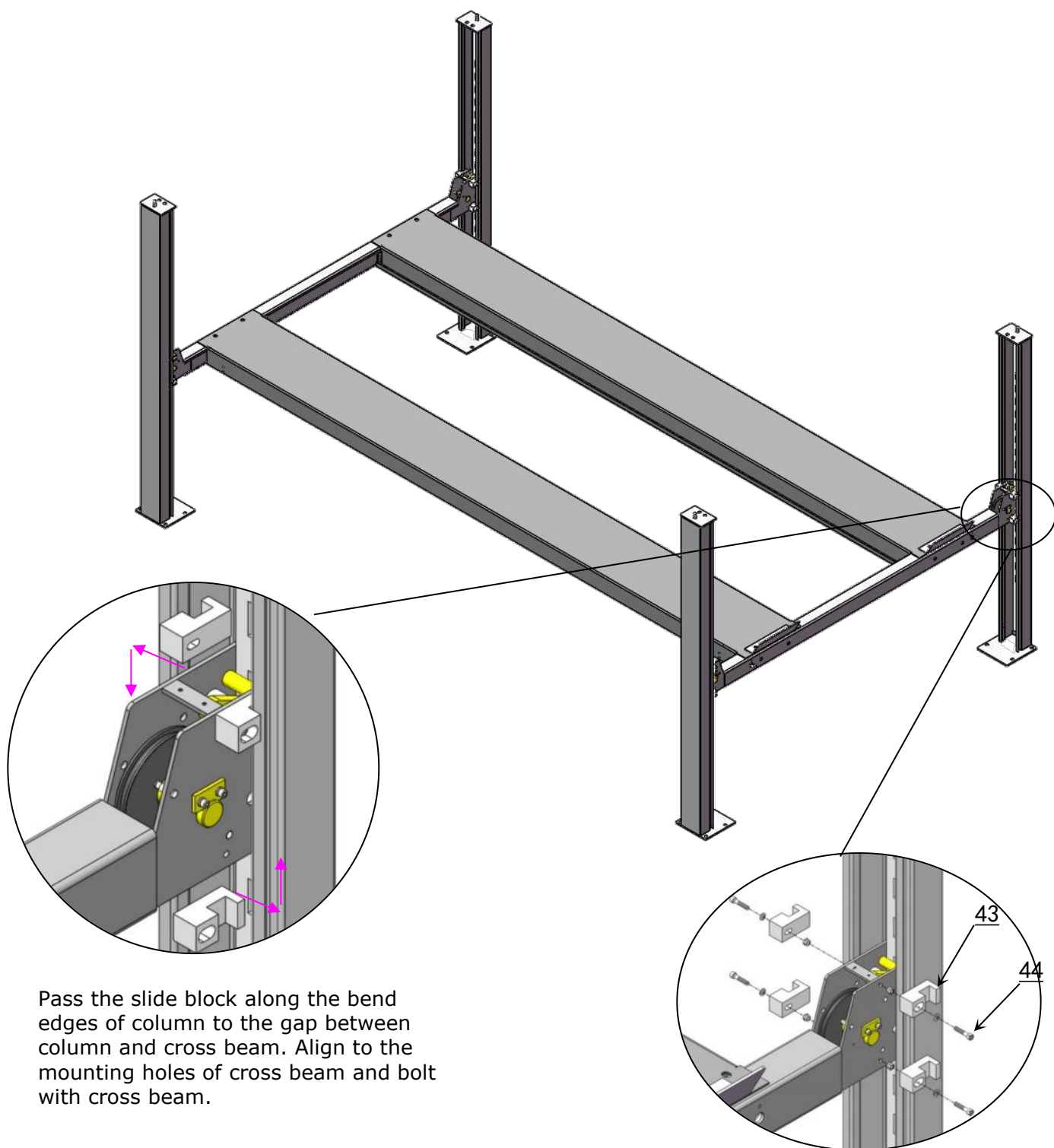

Pass the slide block along the bend edges of column to the gap between column and cross beam. Align to the mounting holes of cross beam and bolt with cross beam.

Note: DO NOT completely tighten the limit sliders, loosen 1/4 turn after tighten the socket bolt and nylok nut .

Fig. 24

I. Install safety device connecting rod, release handle and coupling sleeve.

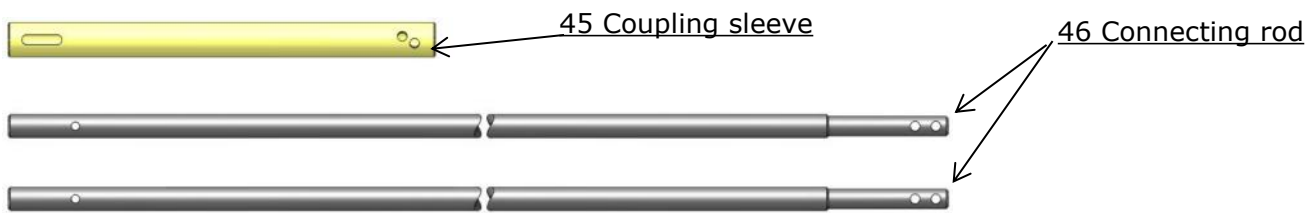

1. Install safety device connecting rod and release handle, see Fig 25.

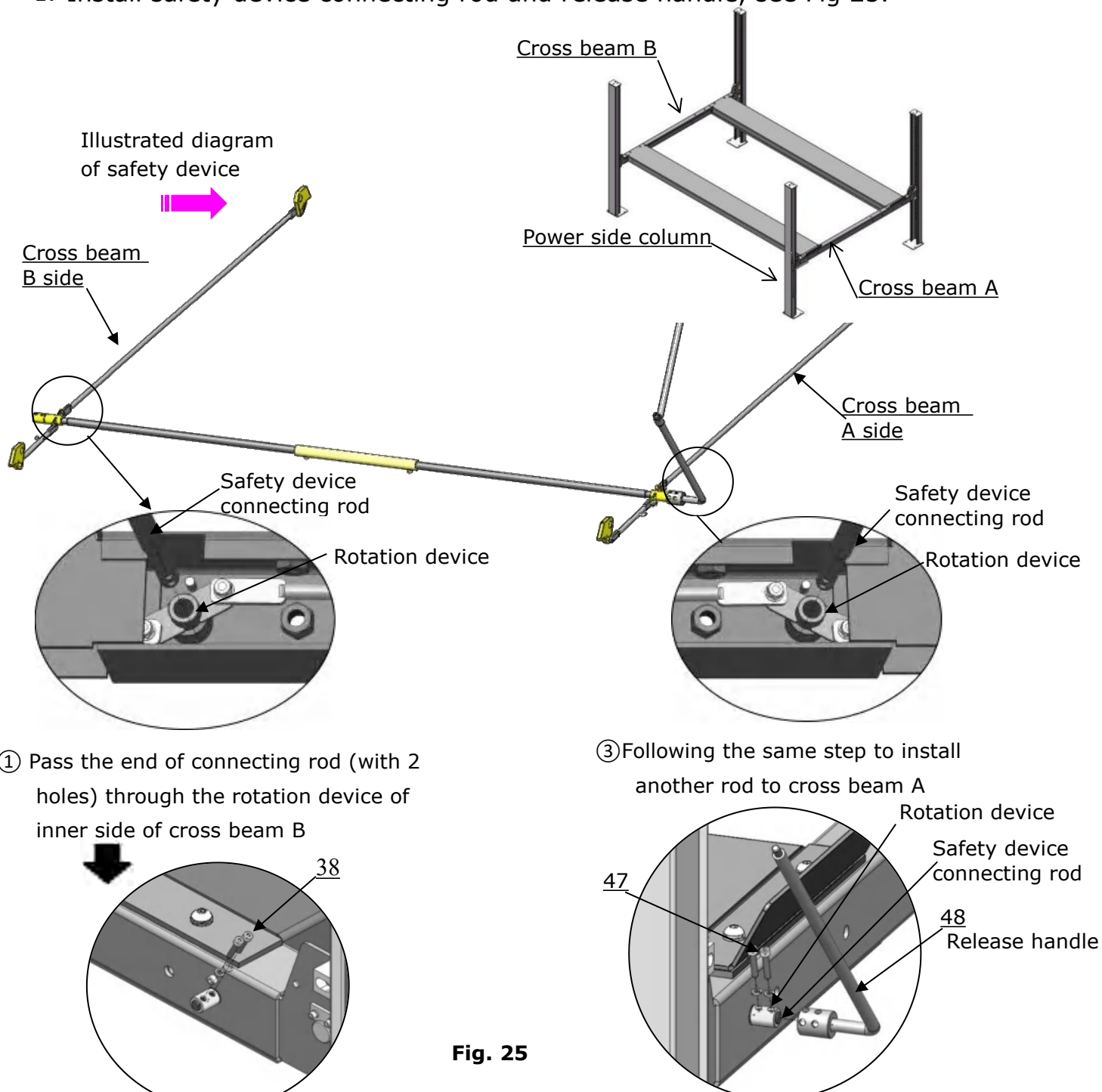

① Pass the end of connecting rod (with 2 holes) through the rotation device of inner side of cross beam B

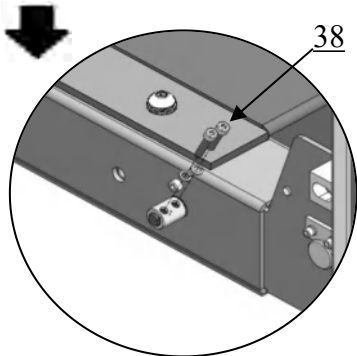

② Align the mounting hole on the outside of cross beam B, tighten with M8*35 socket bolt with lock washer.

③ Following the same step to install another rod to cross beam A

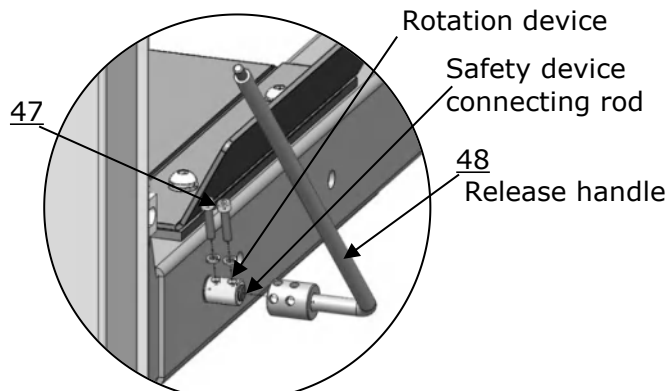

④ Install Release handle on the cross beam A, align the mounting hole, tighten with M8*35 socket bolt with lock washer.

Fig. 25

⑤ Install extended release handle and pull rope.

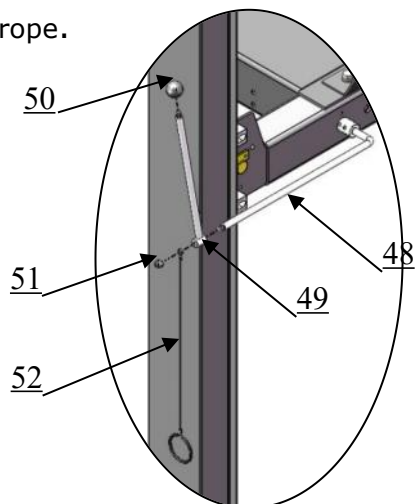

2. Install coupling sleeve

2.1, Coupling sleeve installation illustration when power side column is in the position as shown below. See fig 26.

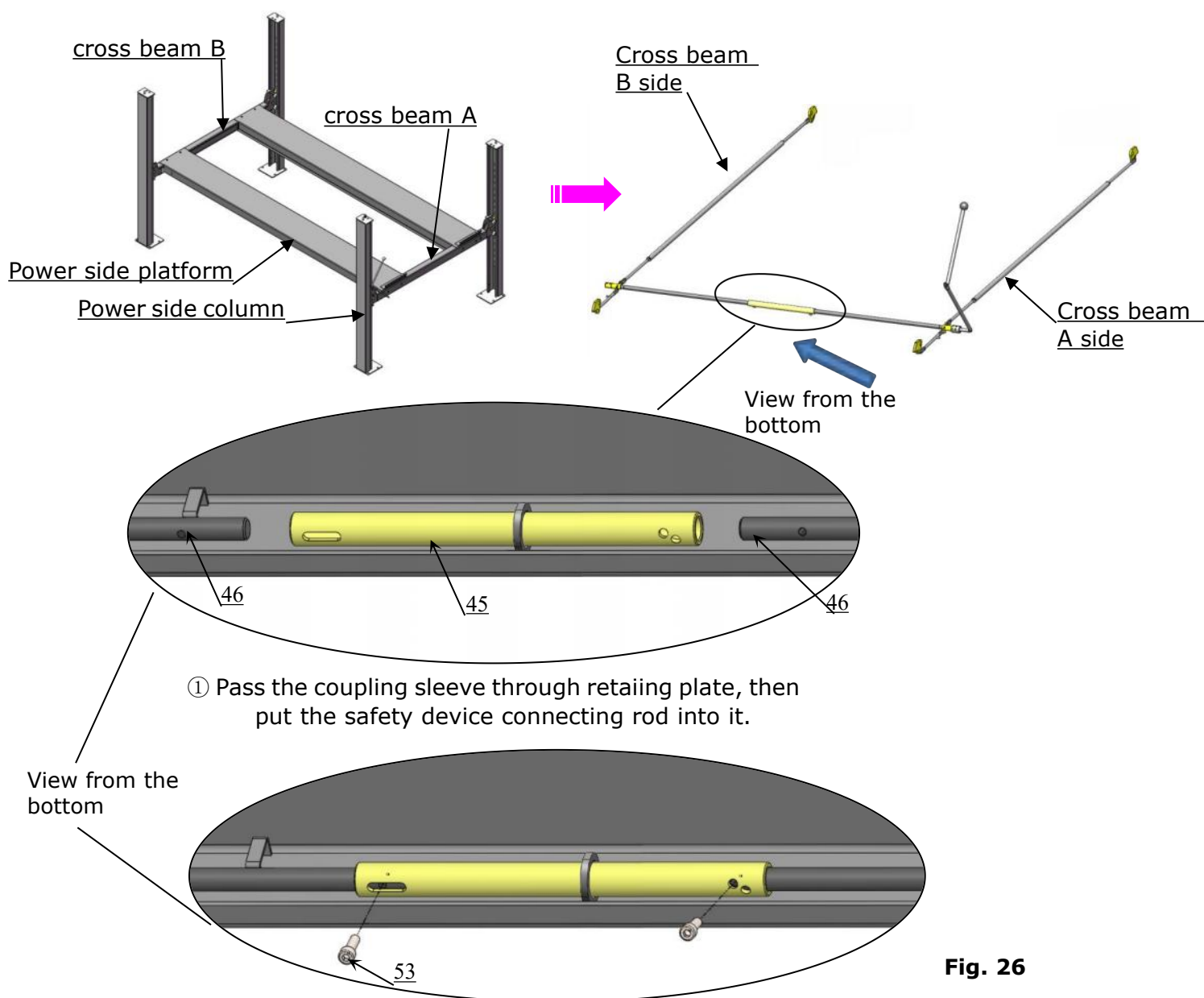

Fig. 26

② Align the holes that connecting the connecting rod and coupling sleeve as show above, tighten with M8*20 screw with lock washer.

Note: There should be 1 to 2mm clearance between the screw head and the coupling sleeve after tighten the screw.

2.2, Coupling sleeve installation illustration when power side column is in the position as shown below. See Fig 27

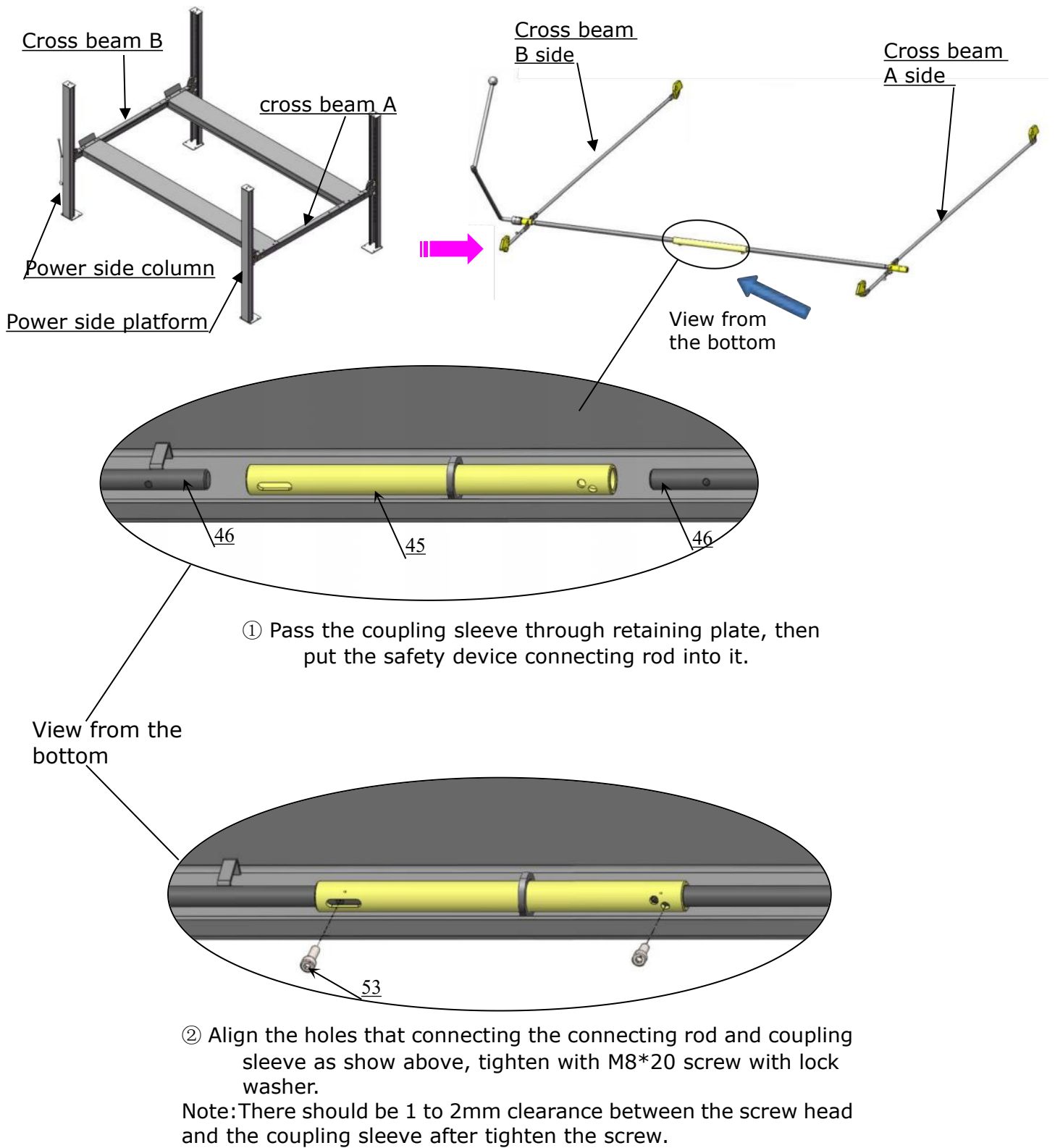
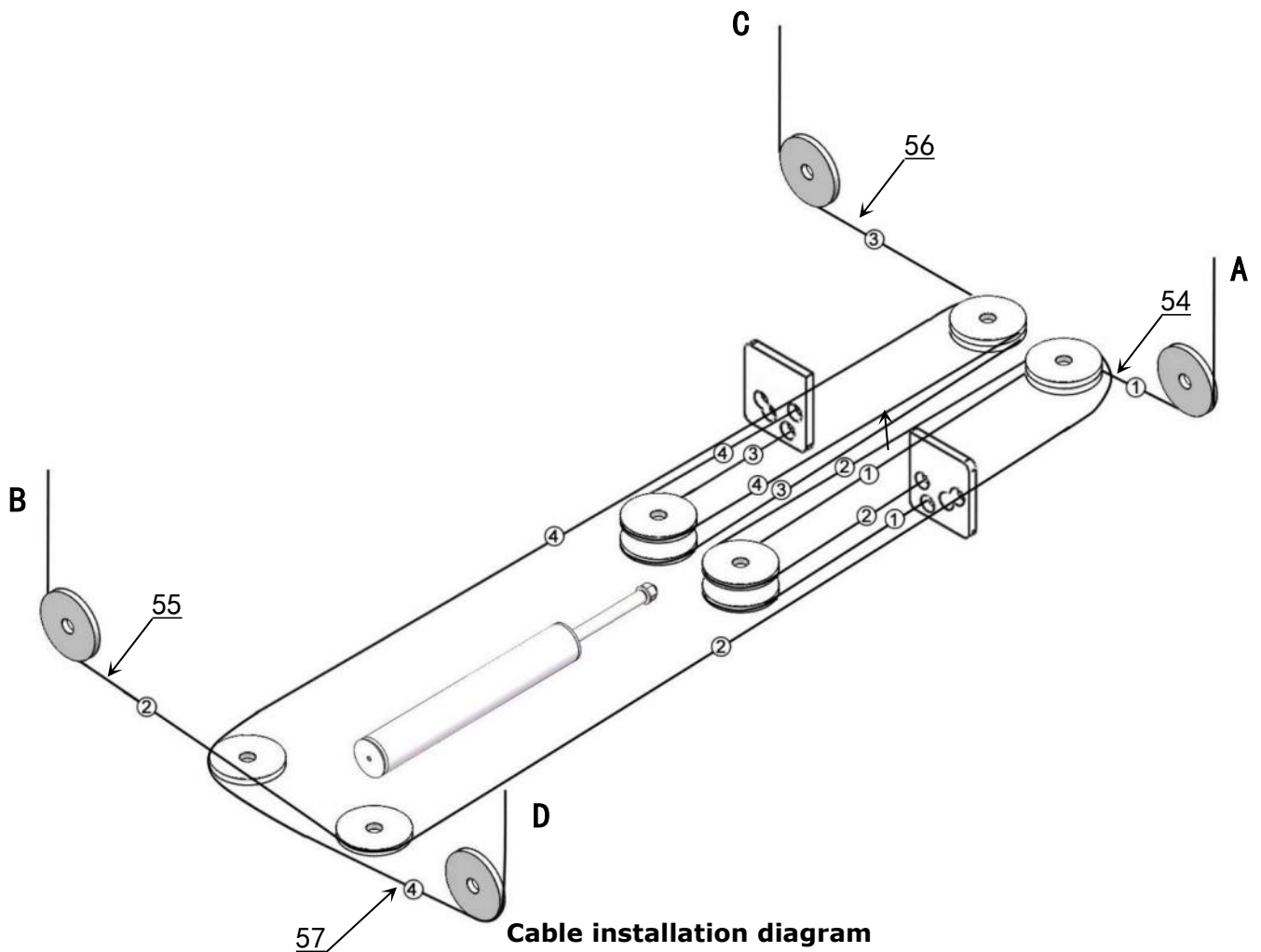
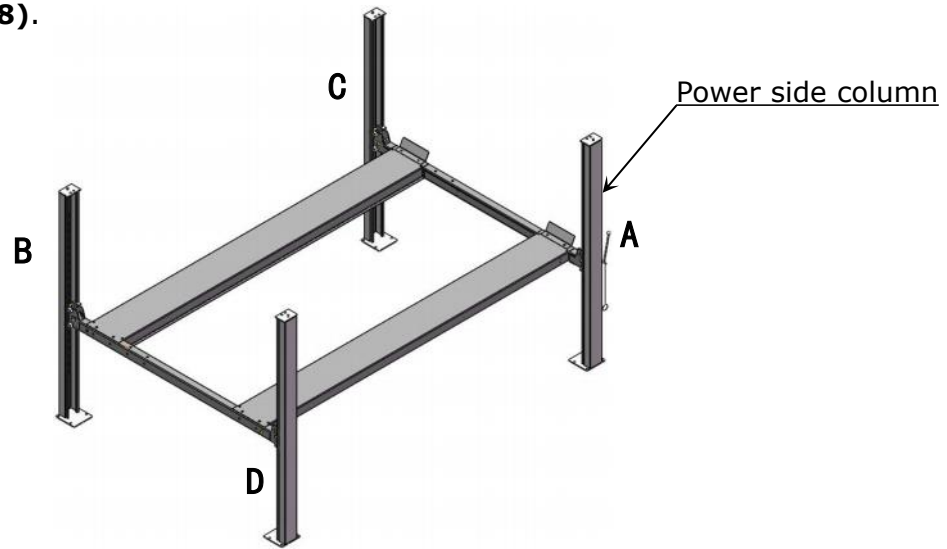

Fig. 27

J.Illustration for cable installation

1. Pass through the cables from the platform to the columns according to the number of the cables (See Fig. 28).



NO. Cable	①	②	③	④
408-HPX Length (inc. cable fitting)	210 1/16" (5336mm)	482 3/16" (12247mm)	294" (7467mm)	398 1/16" (10111mm)

2. Pass The cables through the cross beam to top plate of columns and screw with cable nuts
(See Fig. 29).

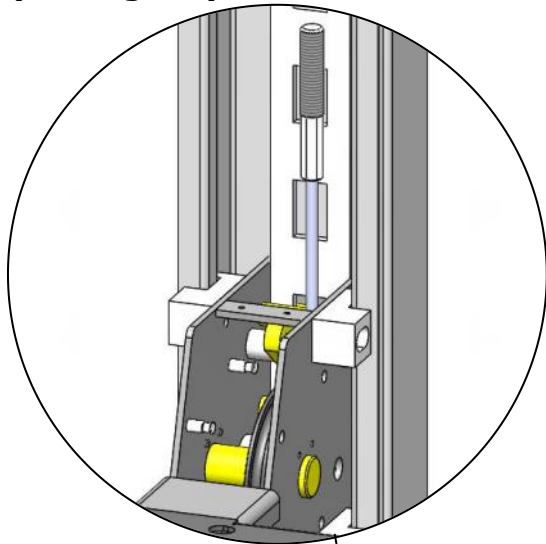

Pass the cable through cross beam pulley and tension pulley

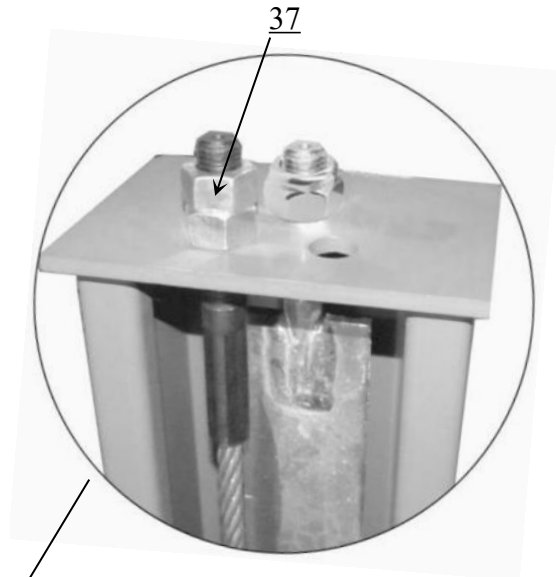

Pass the cable through the top plate and c lock it with cable nut

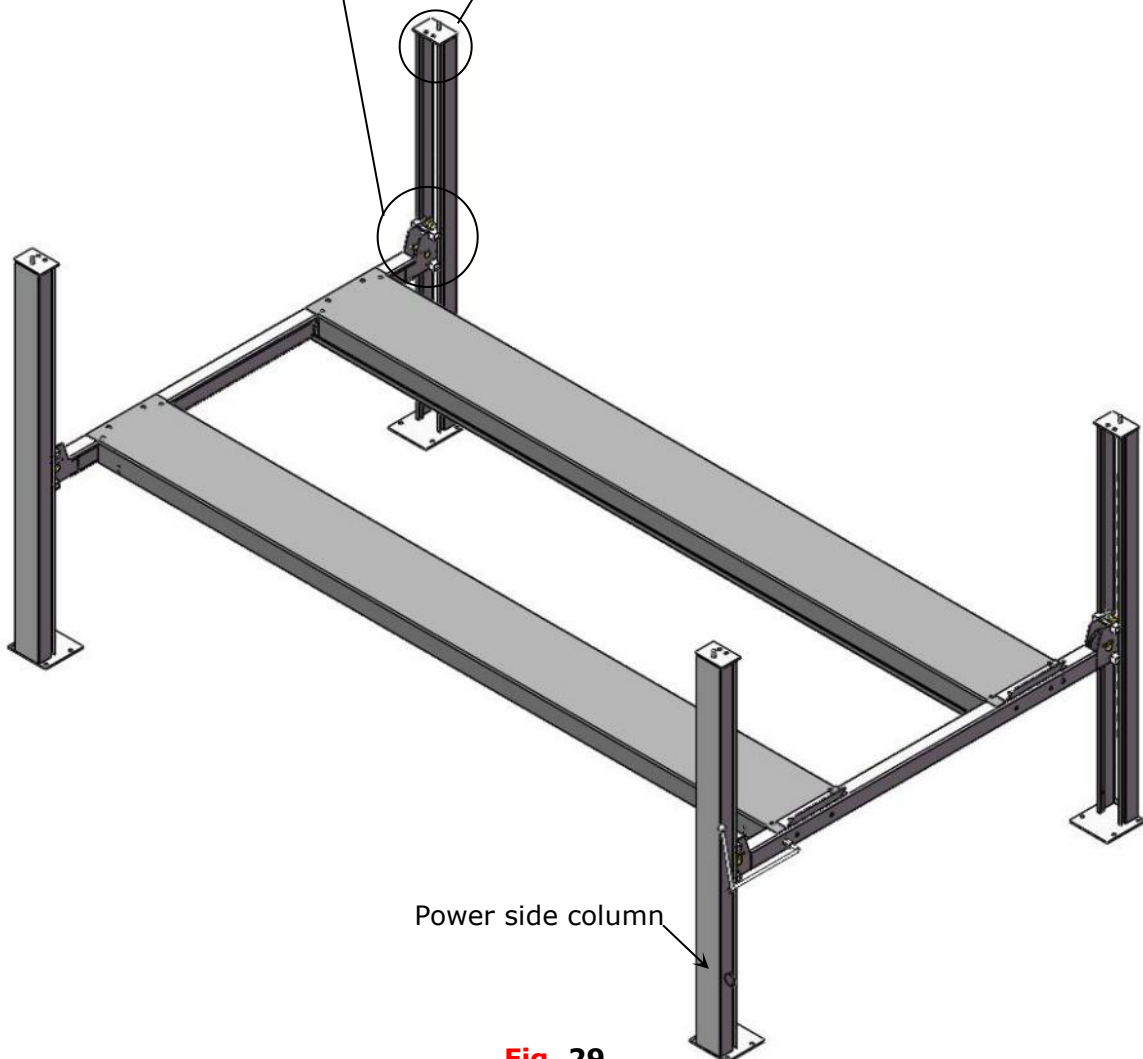

Power side column

Fig. 29

3. The sketched overview of cables finally installed under platform. (See Fig. 30).

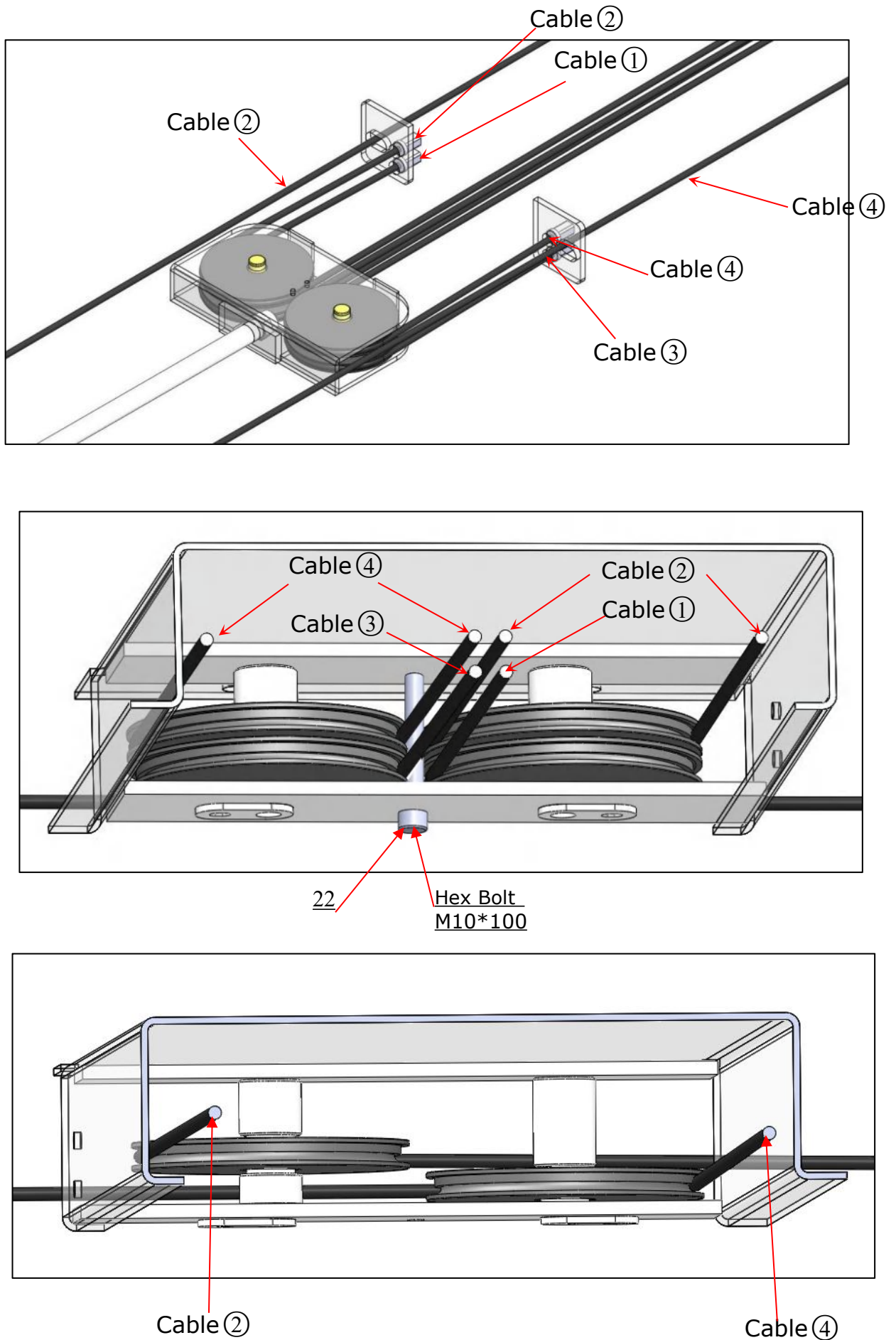

Fig. 30

4. Install tension spring and cross beam protective cover. **(See Fig. 31).**

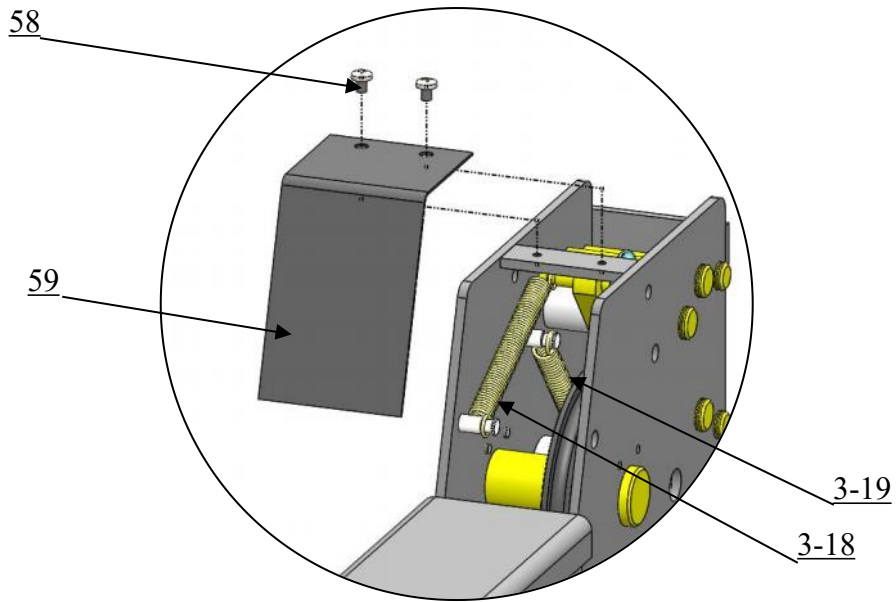

Fig. 29

K. Install power unit

Fixing the motor installing plate to the power side column. And install the power unit to the installing plate. See fig 32.

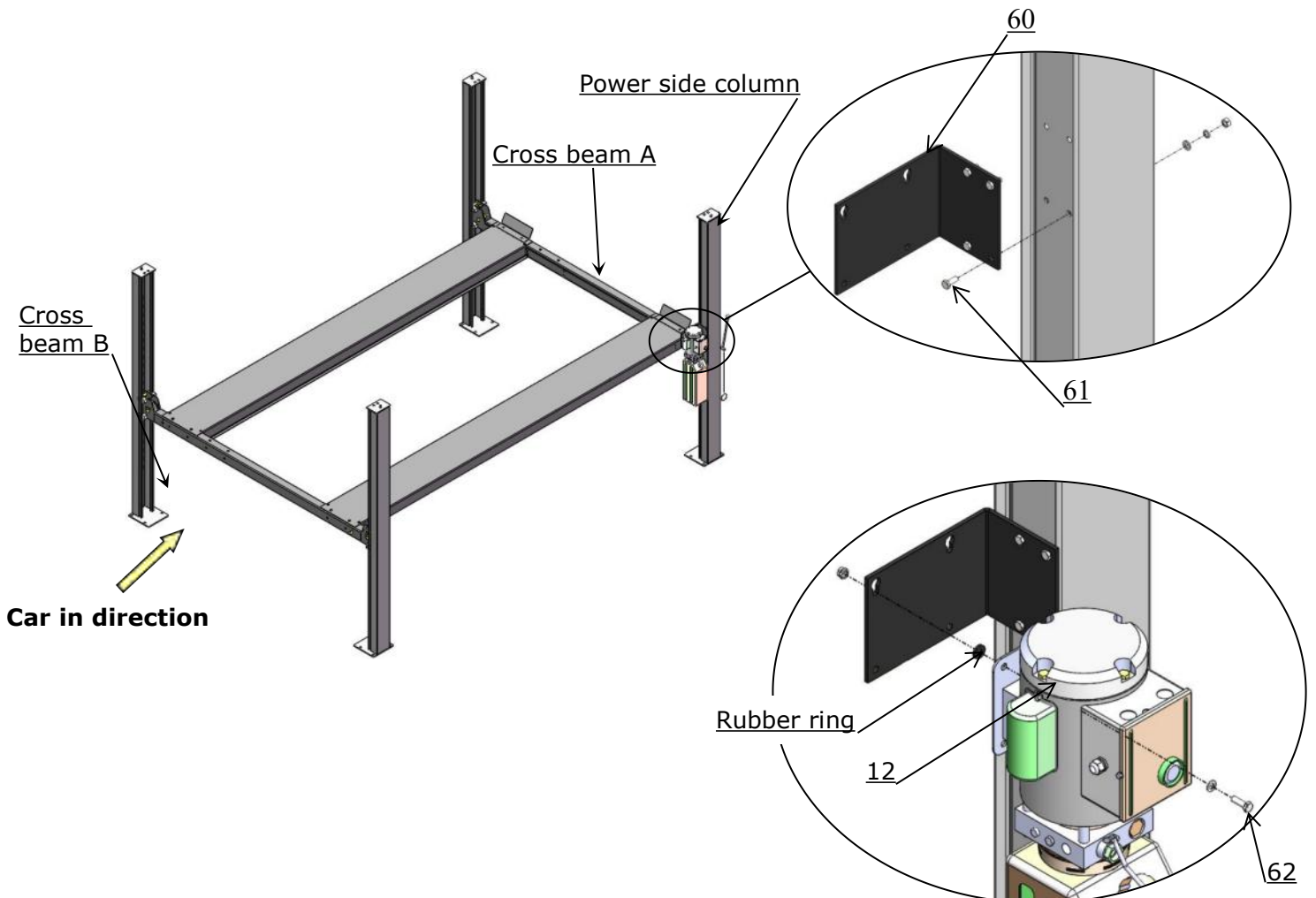

Fig.32

L.Install Hydraulic System

1. For power unit installed to the column that connected to cross beam A (See Fig. 33)

Note: Oil hoses connected to oil cylinder must be passed above the cable and cylinder inlet port should be upward a little to avoid the oil hose scratched by cable.

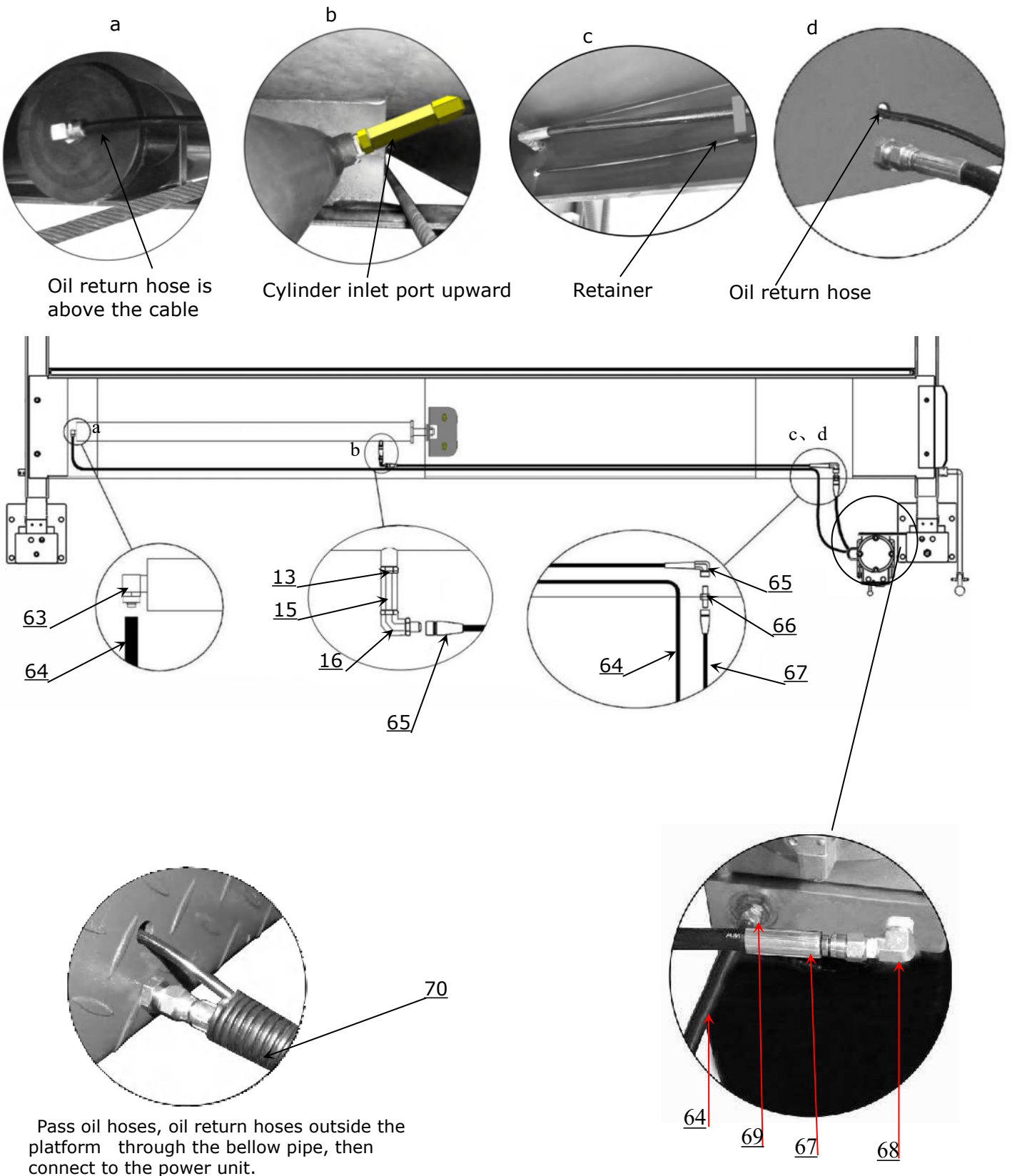

Fig. 33

M. Install the anchor bolts.

1. Check the plumbness of columns with leveling instrument and adjusting with the shims.

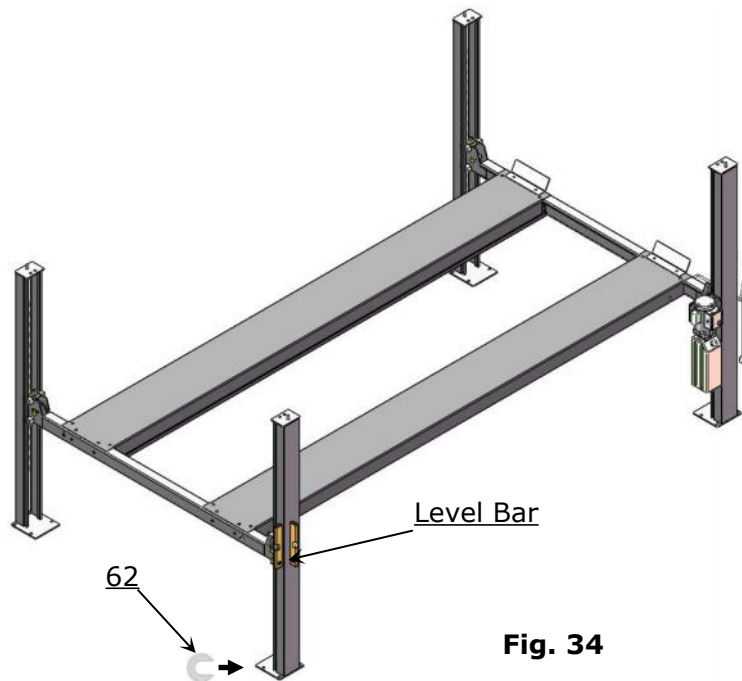

Fig. 34

2. Prepare the anchor bolts (See Fig. 35).

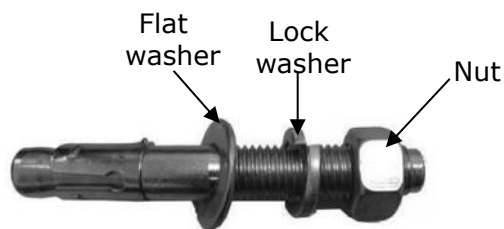

Fig. 35

3. Use the prescribed rotary hammer drill, drill all the anchor holes and install the anchor bolts and tighten all nuts. (See Fig. 36)

Note: The tightening torque for the anchor bolt is 150N.m ,anchor bolts should be driven into the ground at least 90mm(3 1/2").

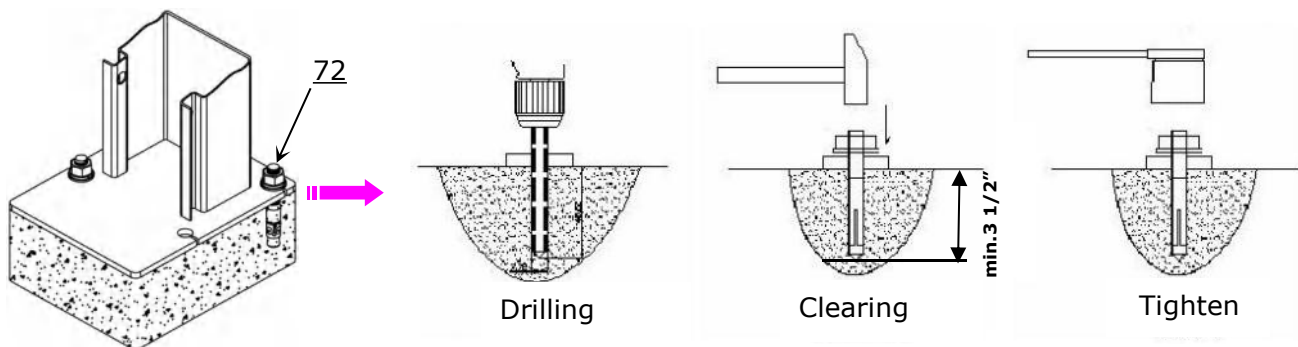
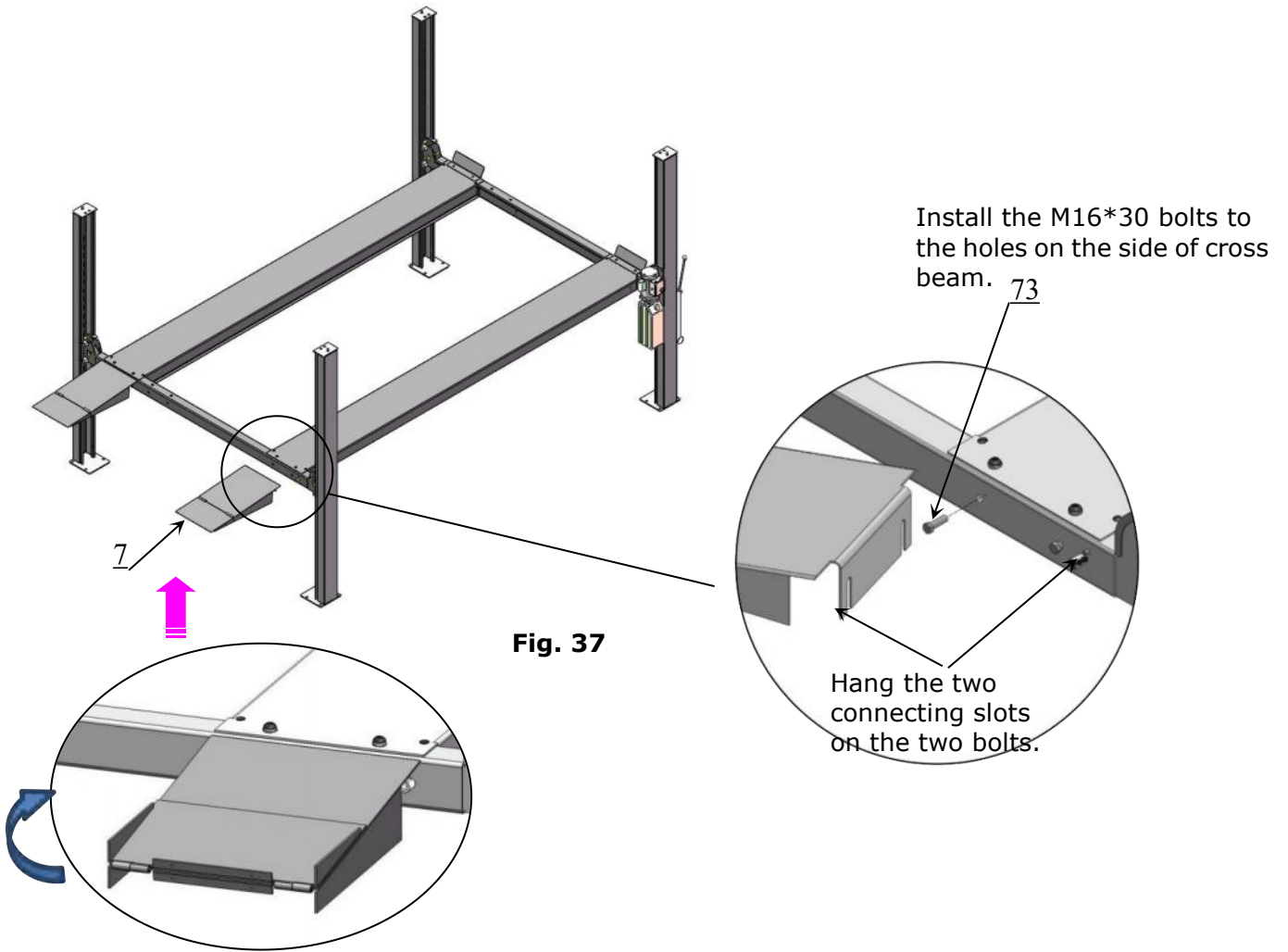

Fig. 36

N. Install foldable drive-in ramp ass., jack tray and plastic oil tray.

Install the M16*30 bolts into the cross beam according to the below diagram, then hang the 4 units foldable drive-in ramps assy. on the bolts. See fig 37.



Fold up the front half of ramps after the car is parked well.

Exploded view of foldable drive-in ramps assembly

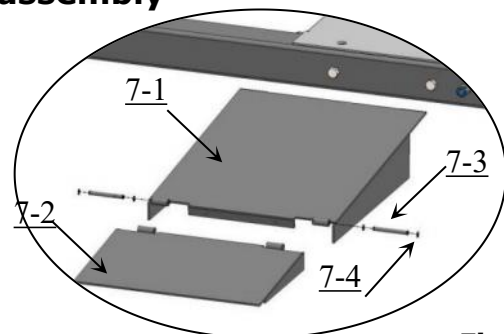

Fig. 38

Parts List of foldable drive-in ramps assembly (1104533025C-01)

Item	Part No.	Description	Qty.
7-1	1104533025A-01	Foldable drive-in ramps #1	2
7-2	1104533026A-01	Foldable drive-in ramps #2	2
7-3	1104543021	Connect pin	4
7-4	10209010	Clip ring	8

O.Adjustable trailer platform and trailer extended platform (See Fig. 39)

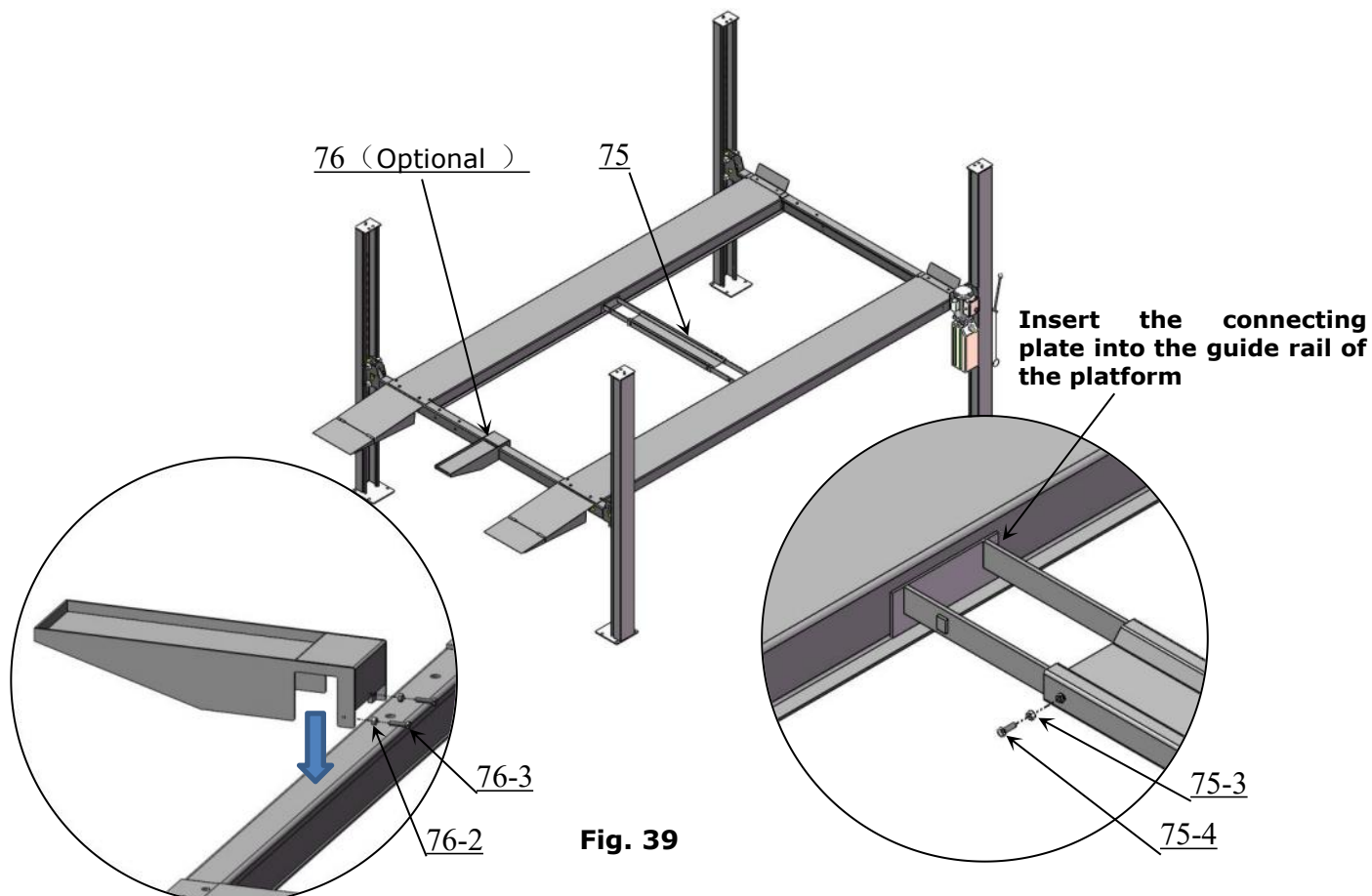

Fig. 39

Insert the opening downward into the crossbeam and tighten the screws

After adjusting the distance between the sliding frame, tighten the screws.

Exploded view of adjustable trailer platform

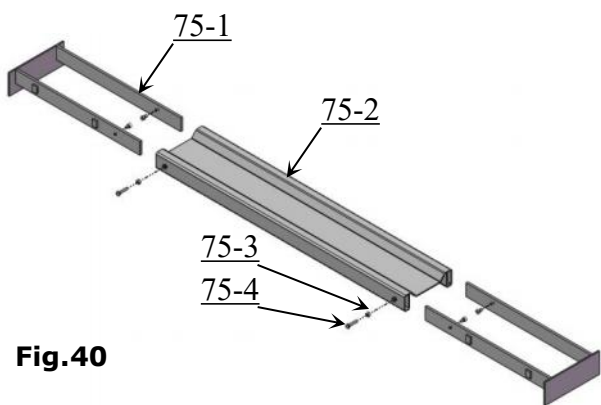

Fig.40

Parts List of adjustable trailer platform (40817)

No.	Part Number	Description	Qty
75-1	1104403001A	Adjustable trailer platform	1
75-2	1104403005A	Slide plate device	2
75-3	10217002	Hex nut M8	2
75-4	10209003	Hex bolt M8*25	2
75-5	40100001	Socket bolt M8*12	4

Exploded view of trailer Extended Platform

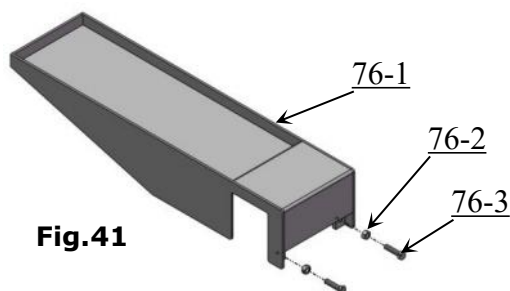

Fig.41

Parts List of trailer extended platform (40818)

No.	Part Number	Description	Qty
76-1	1104802006A	Trailer extended platform	1
76-2	10209021	Hex nut M10	2
76-3	10690018	Hex bolt M10*40	2

P. Install Electrical System

Connect the power source according to the data plate of Motor.

Note: For the safety of operators, the power wiring must contact the floor well.

Single phase motor

Connect the two power supply wire (hot wire **L1** and **L3**) to terminals of AC contactor marked **L1, L3** respectively. Connect the earth wire to earth strip.

Note: if the local power are with 2 live wires, connect them to L1, L3 terminal of AC contactor respectively.

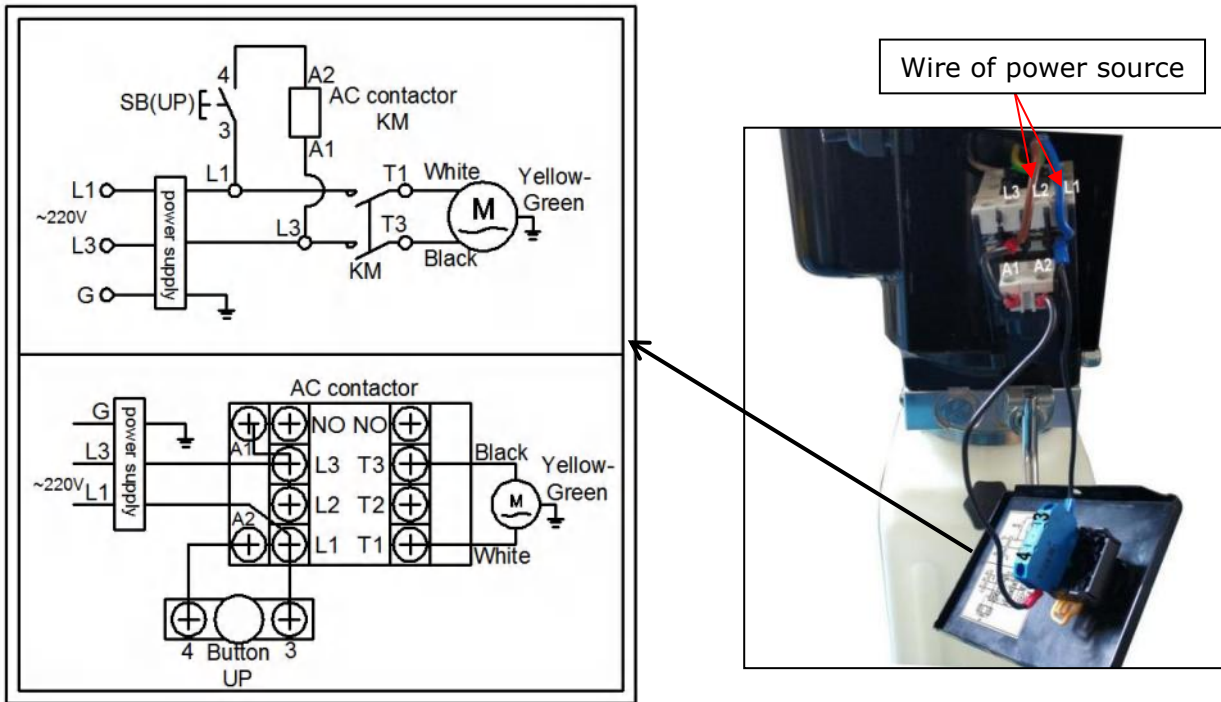

Fig. 37

⚠ DANGER All electrical wiring must be performed by a licensed and certified electrician. Before ensuring the main power has disconnected from the lift and cannot be re-applied until all procedures have been completed, don not perform any maintenance or installation to the lift.

⚠ DANGER Do not use the lift if the wires are damaged or severely worn. If the vehicle rises without noticing damage or extreme wear, carefully lower the vehicle to the ground. Once the lift is on the ground, remove it, disconnect the power, and arrange for protection.

IV. EXPLODED VIEW

Model 408-HPX

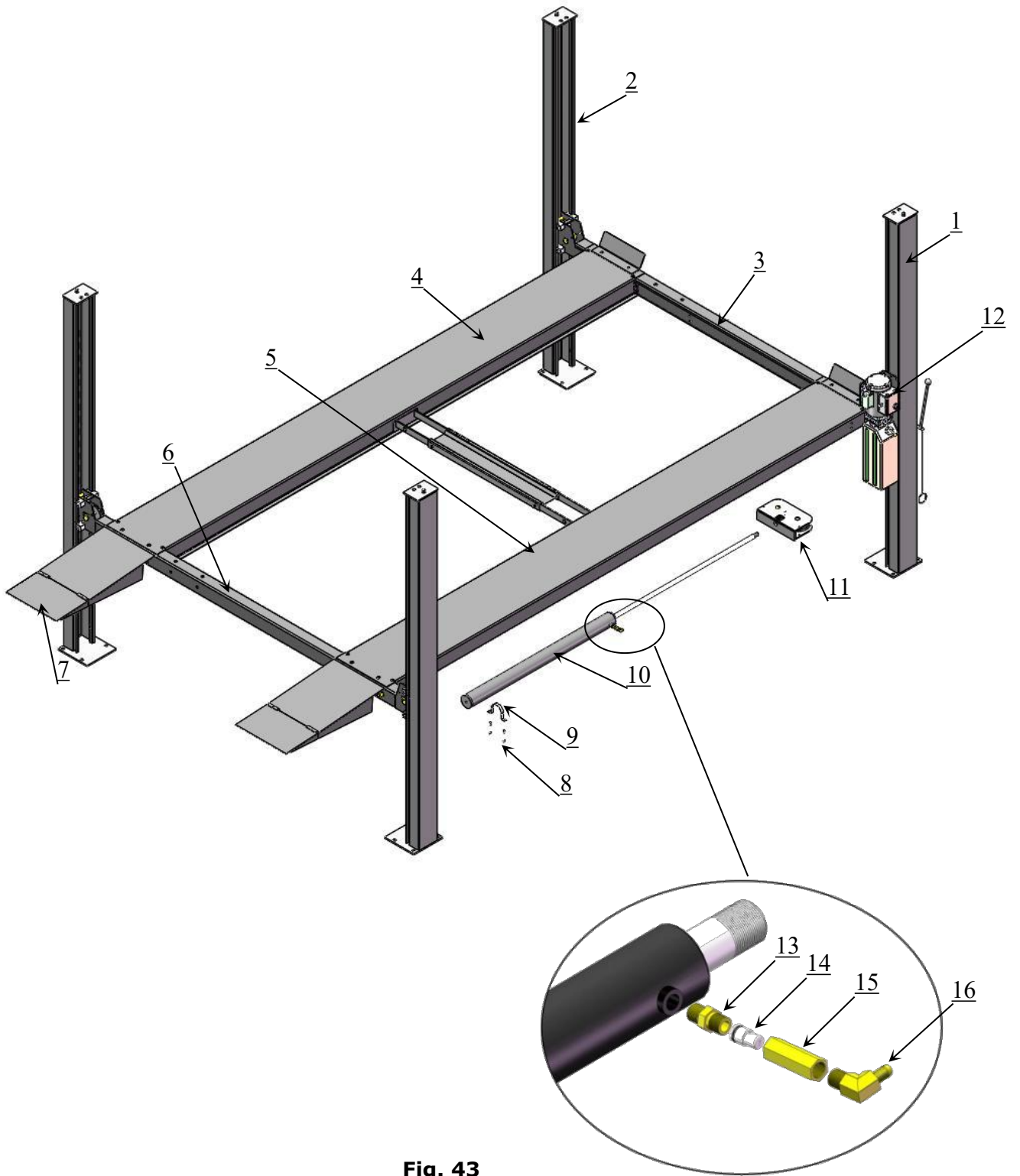

Fig. 43

Power-side platform

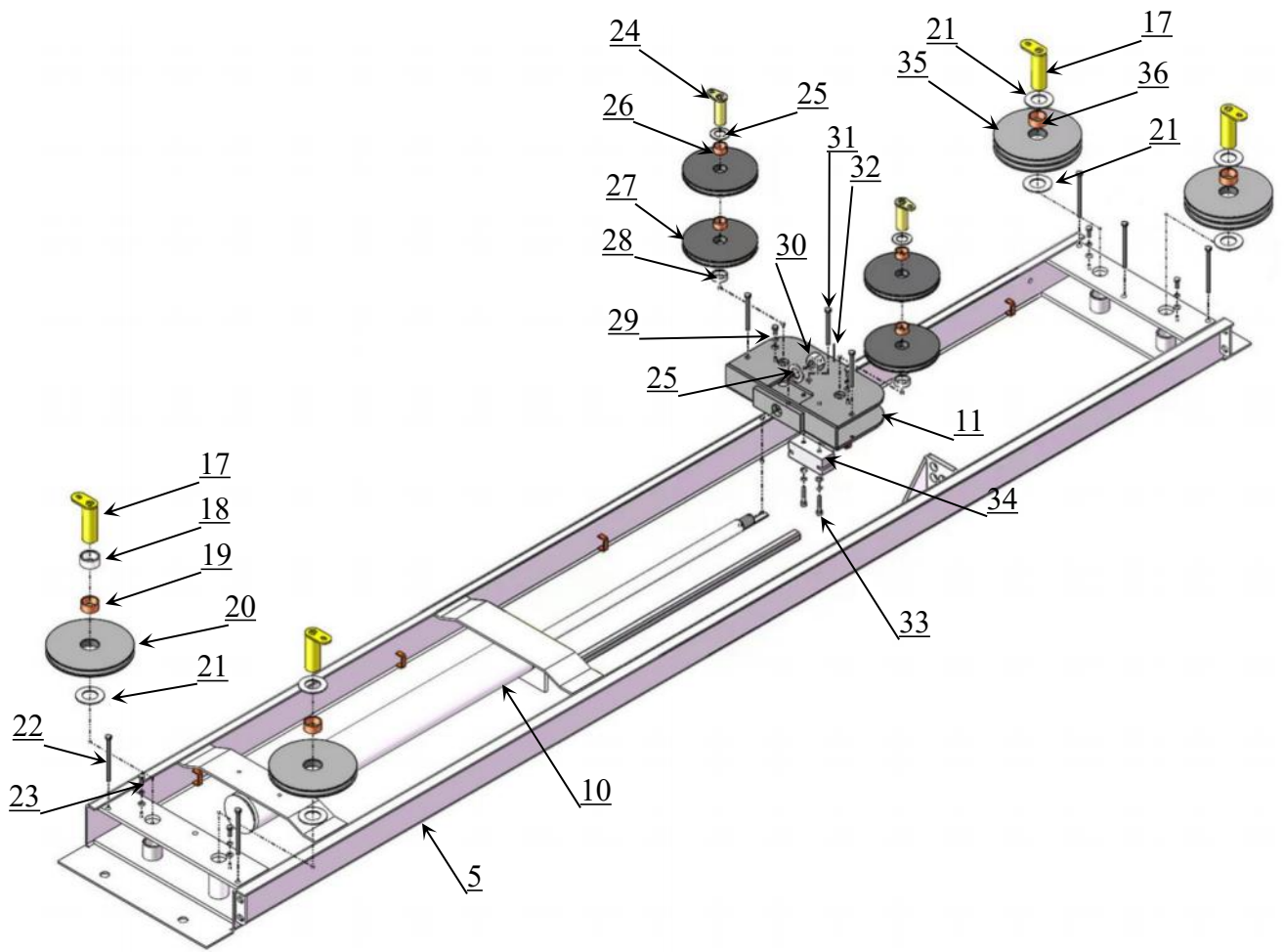

Fig. 44

PARTS LIST FOR MODEL 408-HPX

Item	Part No.	Description	Qty.
1	11410074-03	Power side column	1
2	11410075-03	Off side column	3
3	1104802001C	Cross beam A	1
4	1104803001B	Off side platform	1
5	1104803001A	Power side Platform	1
6	1104802002C	Cross beam B	1
7	1104533025C-01	Foldable drive-in ramp assy.	2
8	1004574011	Hex Bolt M8*16 (With nylok nut)	2
9	11420012A	Cylinder fixing ring	1
10	C804401	Cylinder	1
11	1104533013A-01	Piston rod connecting seat	1
12		Manual power unit	1
13	11420243	Straight fitting	1
14	C802003	Compensation valve	1
15	11420245	Straight fitting	1
16	10201020	90° fitting	1
17	1101533012A	Pulley Pin	4
18	1104533020	Cushion bushing	1
19	10420132A	Bronze bushing	2
20	11420024B	Pulley	2
21	10420023A	Flat washer φ36	15
22	10650502	Socket Bolt M10*100	5
23	1004574012	Hex bolt M8*20	4
24	1104533017A-01	Pulley Pin	2
25	1104533024-01	Cushion cover	2
26	1004542002	Bronze bushing	4
27	1104533011	Pulley	4
28	10481005	Flat washer φ30	2
29	1002735012	Hex bolt M8*16 (include flat wahser, lock washer)	2
30	10410012	Hex Nut M24	1
31	33101362	Socket Bolt M10*75	3
32	10201005	Cotter pin	1
33	1004534010	Socket Bolt M8*45(include flat washer, lock washer)	2
34	1004533006-01	Slider	1
35	1104533023	Dual groove pulley	2
36	10530042	Bronze bushing	2
37	10420175A	Hex Nut M20	12
37A	40100011	Self locking nut M20	4
38	11410073-02	Safety ladder L=91 1/2"	4
39	1004544011	Cup head bolt M16*30 (include flat washer, nylok nut)	4
40	1004574016	Hex bolt M16*35 (include flat washer, nylok nut)	4

Item	Part No.	Description	Qty.
41	11410015-1	Tire stop plate	2
42	1004574017	Socket Bolt M12*20(8.8class) (include flat wahser, lock washer)	8
43	10410016A	Slider	16
44	1004574018	Socket boltM8*40 (include flat washer, nylok nut)	16
45	11410024-01	Coupling sleeve	1
46	11410023-02	Safety device connecting rod L=81 5/8"	2
47	1004574019	Socket bolM8*35(include lock washer)	4
48	10409702001A	Release handle	1
49	11410100	Extended release handle	1
50	10217005	Nylok nut M10	1
51	10209056	Nylok nut M10	1
52	1004554006	Pull rope	1
53	10420043	Socket bolt M8*20	2
54	1004814003	① Sync cable assy.L=210 1/16"	1
55	1004814004	② Sync cable assy.L=482 3/16"	1
56	1004814002	③ Sync cable assy.L=294"	1
57	1004814001	④ Sync cable assy. L=398 1/16"	1
58	10209145A	Round head socket boltM6*12	8
59	1104202002	Cross beam protective cover	4
60	1104551003	Motor fixing bracket	1
61	1004574011	Hex bolt M8*20 (include flat washer, lock washer,Hex nut)	4
62	1002215009	Hex bolt M8*30 (include flat washer, rubber ring,nylok nut)	4
63	10420166	90° screw fitting	1
64	1004814005	Oil return hose assy. L=223 1/2"	1
65	1004804006	Oil Hose assy. L=106 5/8"	1
66	10420120	Extended straight fitting with nut	1
67	1004533007	Oil hose assy. L=55 15/16"	1
68	10209060	90° fitting for power unit	1
69	10420095	Straight screw fitting	1
70	1004533008	Bellow pipe L=55 1/8"	1
71	10201090	Shim (1mm)	20
7172	10620065	Shim (2mm)	20
	10209059	Anchor bolts 3/4*5-1/2	16
73	10410013	Hex bolt M16*30	4
74	1004814006	Parts box	1
75	40817	Adjustable trailer platform	1
76	40818	Trailer Extended Platform (Optional)	1

4.1 CYLINDERS EXPLODED VIEW C804403

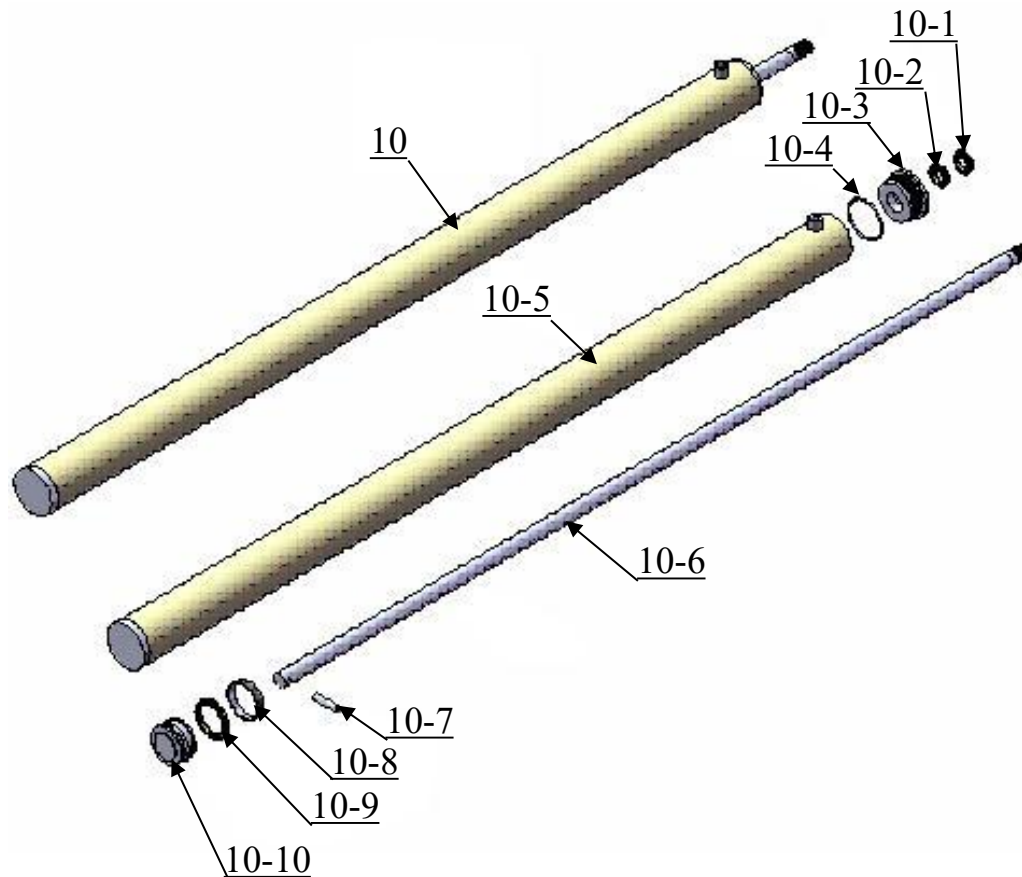

Fig. 45

Parts List

Item	Part No.	Description	Qty.
10-1	10420059	Dust ring	1
10-2	1004016001	Y- Ring USH	1
10-3	11420061-01	End cover	1
10-4	10420062	O- Ring	1
10-5	1104806001A	Cylinder components	1
10-6	1104806002	Piston Rod	1
10-7	11420065	Cylindrical pin	1
10-8	10420066	Support Ring	1
10-9	10420067-01	Y- Ring USH	1
10-10	11420068	Piston	1

4.2 CROSS BEAM ASSY.EXPLODED VIEW (11410003A-03)

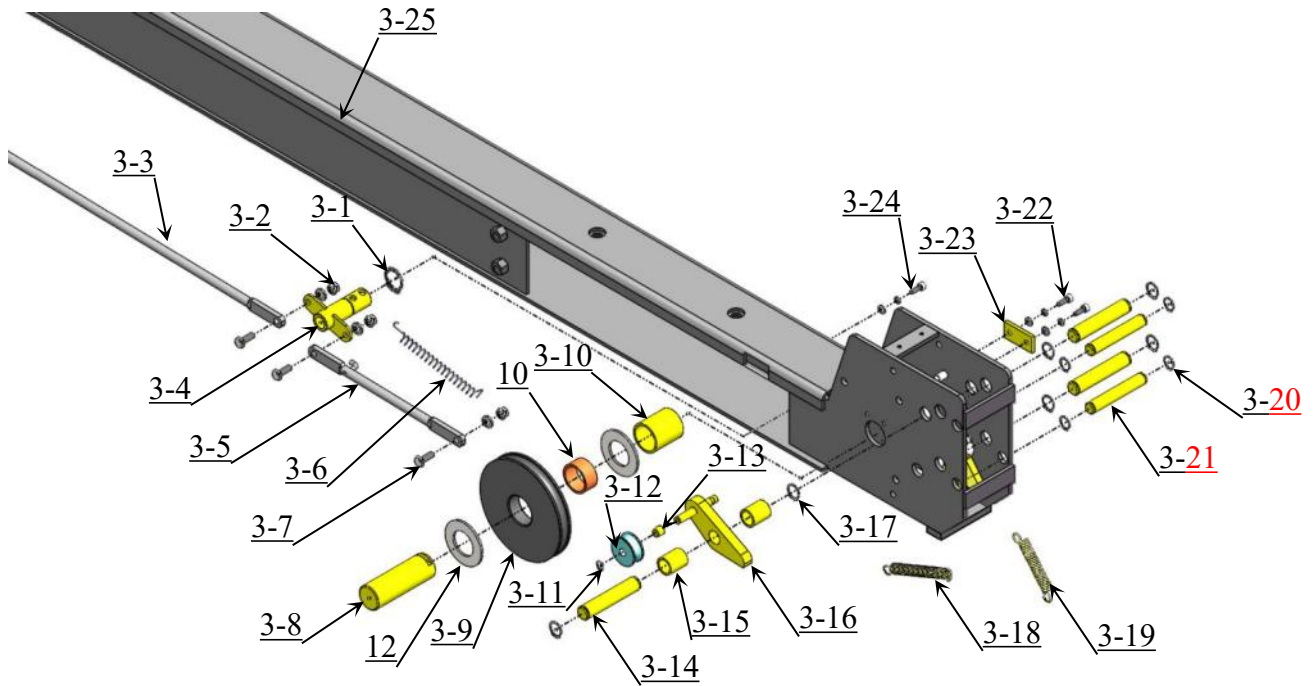

Fig.46

Parts For cross beam

Item	Part No.	Description	Qty.
3-1	10206032	Clip Ring	2
3-2	1004574013	Hex Bolt M8*20 (with washer, self-locking nut)	4
3-3	1104242003	Connecting bar for safety lock	2
3-4	1104572003A	Safety lock rotated device assy.	2
3-5	11410033-04	Connecting bar assy. for safety lock	2
3-6	1004242001	Spring	2
3-7	1004574014	Hex Bolt M8*25 (with washer, self-locking nut)	4
3-8	11420041A	Pulley pin	4
3-9	1104202001	Pulley	4
3-10	11420040A	Pulley pin sleeve	4
3-11	10209010	Clip ring	4
3-12	10420035	Tension pulley	4
3-13	11420174	Spacer	4
3-14	11420171	Pin	12
3-15	11420172	Pin Bush	8
3-16	11420175	Slack-cable safety lock (Left & Right)	2 each
3-17	10206019	Clip ring	24
3-18	10420033	Spring	4
3-19	1004542001	Spring	4
3-20	10420037	Clip ring	16
3-21	11420038	Pin	8
3-22	1002735009	Socket Bolt M6*16 (with flat washer, lock washer)	8
3-23	11420044	Stop block	4
3-24	1004544010	Socket Bolt M8*15 (with flat washer, lock washer)	2
3-25	1104802001A	Cross beam A	1
	1104802002A	Cross beam B	1

4.3 Illustration of hydraulic valve for power unit

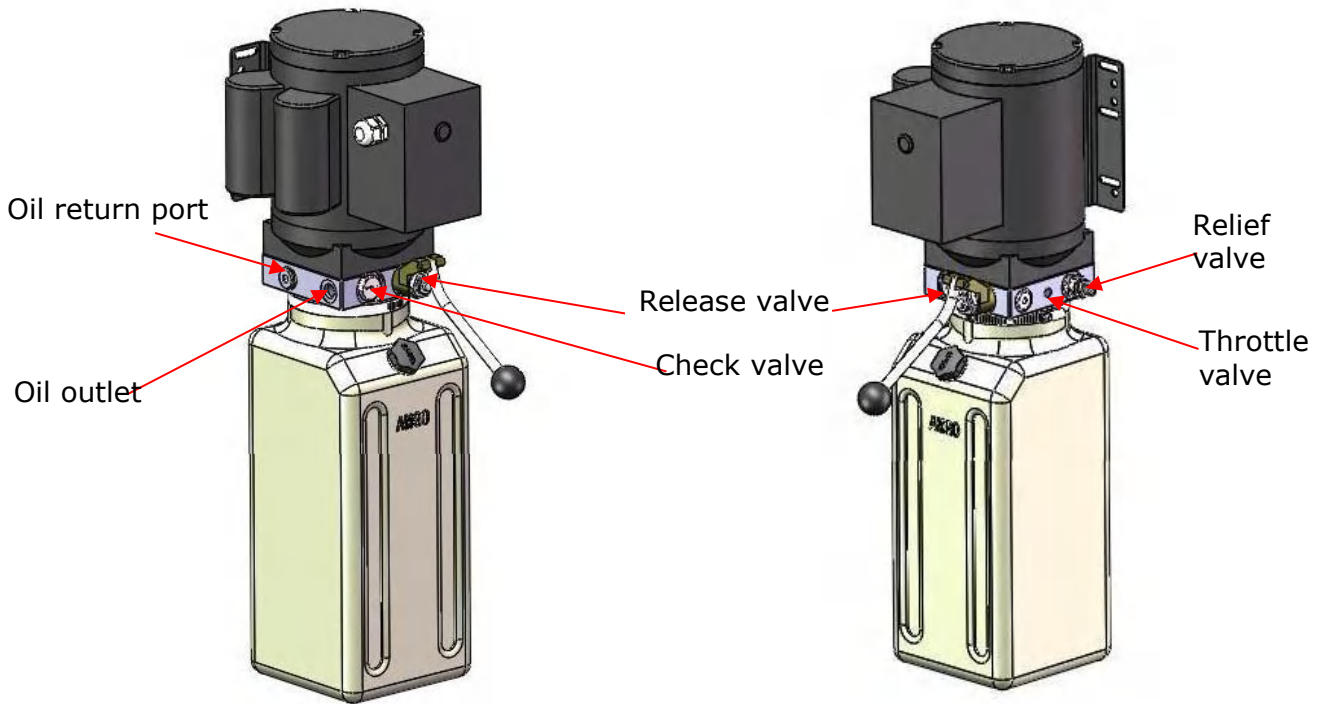
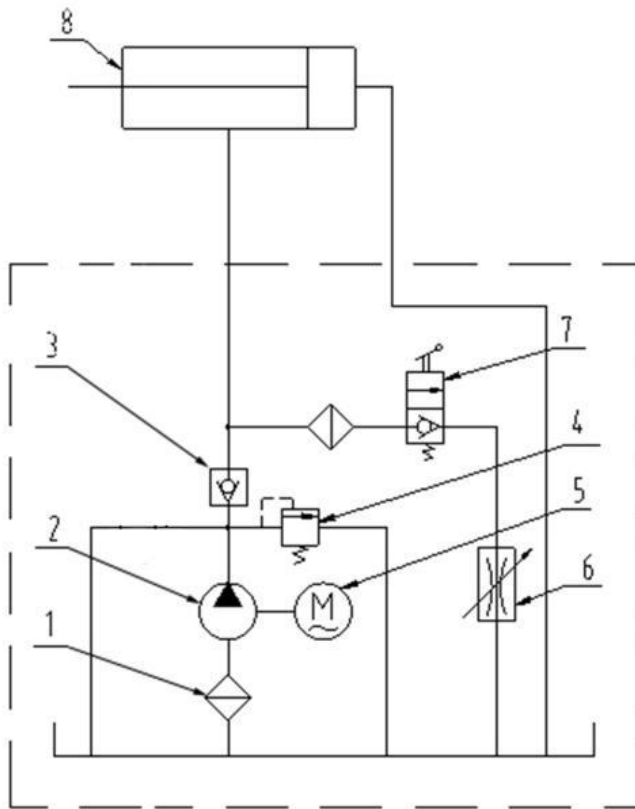

Fig.47

V. TEST RUN

1. Fill the oil tank with around hydraulic oil (in order to ensure the service life of the hydraulic system and ensure the best condition of the equipment, please fill in #46 high-quality anti-wear hydraulic oil).
2. Press the power unit button, until the four cables are tightened. Check the coordination between the cables and the pulleys, the cables **SHALL NOT** cross or fall out of the pulley.
3. Press the power unit release handle to lock the cross beam on the safety ladder. Adjust the safety ladder nuts to make sure the platforms at same level. Then tighten both the top and bottom nuts of safety ladder.
4. Balance the tension of cables by adjusting the cable nuts. It is a must to run several cycles up/down of the lift when performing synchronization operation.
Make sure all four safety locks can be locked/released at the same time, then tightened all the cable nuts.
5. Make sure the cross beam slide blocks and columns are clearance fit, that the slider blocks can slide smoothly with the column. **DO NOT** tighten the slider blocks.
6. After all above adjustments finished, take the loading test. Firstly low-level load test are taken several times to check the synchronization of operation and all safety locks. If they are no other abnormal phenomena, then take the full cycle load tests several times, otherwise repeat the above adjustments.

Circuit Diagram of Hydraulic System



**N
O
T
E**

- 1. Filter
- 2. Gear pump
- 3. Check valve
- 4. Relief Valve
- 5. Motor
- 6. Throttle Valve
- 7. Release Valve
- 8. Cylinder For

Fig.48

VI. OPERATION INSTRUCTIONS

To lift vehicle

1. Keep clean of site near the lift;
2. Drive in the vehicles on platforms and apply the parking brake.
3. Fold up the front half of drive-in ramps.
4. Power on, push the power unit UP button, lift the vehicles to proper parking position.

Note: Make sure the vehicles are in steady safe status.

5. Press the power unit release handle, the lift goes down and be locked. Check and make sure the lift is locked at the same level locks .

 **WARNING** It is unsafe to work when the lift without locking at safety device after it has been raised. The vehicle may fall, potentially causing damage the vehicle and lift, even causing injury or death to someone nearby.

 **WARNING** AMGO recommends using provided anchor bolts for maintenance or service. If not using anchor bolts, ensure each column is plumb before lifting on level surface.

To lower vehicle

1. Clear obstructions around and under the lift and keep people away from the lift.
2. Push power unit **UP** button to raise the lift 3-5 seconds, then the safety lock is out of lock status. Pull the release handle, make sure the safety lock released, press the power unit release handle, the lift will start to lower.
3. Lower the lift to the lowest position, unfold the front half of drive-in ramps, and drive away the vehicle
4. Turn off the power.

VII. MAINTENANCE SCHEDULE

Monthly:

1. Lubricate cables.
2. Make visual inspection of cables for possible wear or damage.
3. Make visual inspection of hydraulic hoses for possible wear or leakage.
4. Lubricate all rollers, pins and safety devices with 90WT gear oil.

Every six months:

1. Make a visual inspection of all moving parts for possible wear, interference or damage.
2. Check and adjust as necessary, cable tension to ensure synchronization.
3. Check columns for plumbness.

Oil cylinder maintenance:

In order to extend the service life of the oil cylinder, please operate according to the following requirements.

1. Recommend to use N46 anti-wear hydraulic oil.
2. The hydraulic oil of the lifts should be replaced regularly during using. Replace the hydraulic oil 3 months after the first installation. Replace the hydraulic oil once a year afterwards.
3. Make at least one full trip raising and lowering per day. For exhausting the air from the system, which could effectively avoid the corrosion of the cylinder and damage to the seals caused by presence of air or water in the system.
4. Protect the outer surface of the oil cylinder's piston rod from bumping and scratching, and timely clean up the debris on the oil cylinder dust-ring and the piston rod.

⚠ DANGER

Make sure the lift is completely disconnected from the power source before maintenance. If there is any external electrical lock/shutdown device, make sure to implement them before maintenance. The contact with high voltage/current, may cause injury or even death.

VIII. TROUBLE SHOOTING

TROUBLE	CAUSE	REMEDY
Motor does not run	<ol style="list-style-type: none"> 1. Start Button does not work 2. Wiring connections are not in good condition 3. Motor burned out 4. AC contactor burned out 	<ol style="list-style-type: none"> 1. Replace start button 2. Repair all wiring connections 3. Repair or replace motor 4. Replace AC contactor
Motor runs but the lift is not raised	<ol style="list-style-type: none"> 1. Release valve in damage 2. Gear pump in damage 3. Relief valve or check valve in damage 4. Low oil level 	<ol style="list-style-type: none"> 1. Repair or replace 2. Repair or replace 3. Repair or replace 4. Fill tank
Lift does not stay up	<ol style="list-style-type: none"> 1. Release valve out of work 2. Relief valve or check valve leakage. 3. Cylinder or fittings leaks 	Repair or replace
Lift raises too slow	<ol style="list-style-type: none"> 1. Oil line is jammed 2. Motor running on low voltage 3. Oil mixed with air 4. Pump leaks 5. Overload lifting 	<ol style="list-style-type: none"> 1. Clean the oil line 2. Check electrical system 3. Fill tank 4. Repair or replace pump 5. Check load
Lift cannot lower	<ol style="list-style-type: none"> 1. Safety device are not in activated 2. Release valve damaged 	<ol style="list-style-type: none"> 1. Operate again 2. Repair or replace

⚠️ WARNING A lift would be dangerous if operated by inexperienced or distracted operators. Operators should be fully aware that lifting a vehicle is a potentially life-threatening operation, especially if ignoring the mandatory safety precautions.

IX. CAR LIFT SAFETY TIPS

Put this safety tips in a place where you can always alert the operator. Please reference to the lift manufacturer's manual for specific information about the lift.

1. Check the lift daily. If the machine breaks down or has damaged parts, do not operate, and use original equipment parts to repair.
2. **Do not** overload . The rated weight of the manufacturer design is indicated on the label of the lift.
3. Position control of the vehicle and operation of the lift can only be done by a trained and authorized person.
4. **Do not** lift a car with occupants inside. Keep the customers or bystanders away from the lift.
5. Keep the area around the lift free of obstacles, lubricating oil, grease, garbage and other debris for a long time.
6. Carefully drive the vehicle onto the lift and lifting up to the required height for operation.
Noted: lift it high enough if you are working underneath, and make sure the safety devices are locked.
7. **Noted:** removing(install) parts from(to) a vehicle would cause a sudden shift of gravity which may result in instability of the vehicle. Please refer to the vehicle manufacturer's service manual as a recommended procedure if you need remove/install parts from(to) the vehicle
8. Before lowering the lift , make sure all obstacles underneath, include tool tray, tool rack etc., are all removed.

X. LIFT DISPOSAL

When the car lift cannot meet the requirements for normal use and needs to be disposed, it should follow local laws and regulations.



Address:

SC Division: 1931 Joe Rogers Jr Blvd, Manning, SC 29102, USA

TX Division: 4310 Adler Dr., Suite #200, Dallas, TX 75211, USA

<http://www.amgohyd.com>

Manual No.: 72247305
Revision Date: 2026/02